

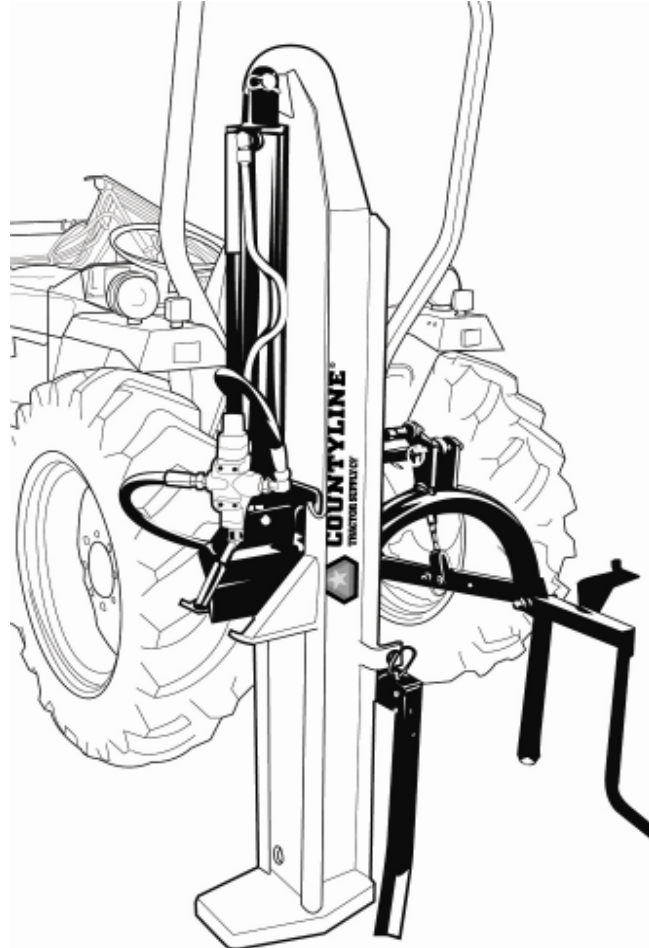

COUNTYLINE®
TRACTOR SUPPLY CO.

3-POINT HITCH VERTICAL/HORIZONTAL LOG SPLITTER



MODEL NO. 2153304

Owner's Manual

ASSEMBLY & OPERATING INSTRUCTIONS



THIS SAFETY ALERT SYMBOL IDENTIFIES IMPORTANT SAFETY MESSAGES IN THIS MANUAL.

Table of Contents

	Page(s)
Important Safety Information.....	1-5
Intended Use	1
Personal Protective Equipment	1
General Safety	1
Safety Decals	2
Preparation of the Log	3
Work Area	3
Operation of the Log Splitter	3
Repair and Maintenance Safety	4
Hydraulic Safety	4
Towing Safety	5
Assembly Instructions	6
Operating Instructions	7
Maintenance	7
Parts List for 3- Point Hitch Log Splitter	8
Parts Breakdown Illustration for 3-Point Hitch Log Splitter	9
Specifications	Back Cover



IMPORTANT SAFETY INFORMATION



WARNING: Read and thoroughly understand all instructions and safety information before assembling or operating this log splitter. Failure to do so may cause serious injury or death. Do not allow anyone to operate this log splitter who has not read this manual. As with all power equipment, a log splitter can be dangerous if assembled or used improperly. Do not operate this log splitter if you have doubts or questions concerning safe operation. Call our customer service department at 1-800-525-8322 to address these concerns.

Si no entiende ingles, se prefiere que busque alguien que interprete las instrucciones para usted.

INTENDED USE

NEVER use this log splitter for any other purposes than splitting wood. It is designed for this use **only**. Any other use can cause serious injury or death.

PERSONAL PROTECTIVE EQUIPMENT



BEFORE operating this log splitter make sure that you wear safety gear such as goggles or safety glasses, steel toed shoes and tight fitting gloves (without loose cuffs or draw strings). Always wear a protective hearing device when operating this log splitter.

NEVER wear loose clothing or jewelry that can be caught by moving parts of the log splitter. Keep clothing and hair away from all moving parts when operating this log splitter.

GENERAL SAFETY

Failure to follow these instructions may result in serious injury or death.

NEVER allow children to operate this log splitter. **NEVER** allow adults lacking proper instructions and understanding to operate this log splitter.

KEEP all people and pets a minimum of 10 feet away from your work area when operating this log splitter. Only the operator is to be near the log splitter during use.

If a helper is assisting in loading logs, **NEVER** actuate the control until the helper is clear of the work area.

NEVER operate the log splitter when under the influence of alcohol, drugs or medication.

NEVER allow a person who is tired or otherwise not alert to use your log splitter.



IMPORTANT SAFETY INFORMATION

SAFETY DECALS

Make sure that all safety warning decals are in good condition and readable. Always replace missing or defaced decals. Write us or call 1-800-525-8322 and they will be sent to you at no charge.

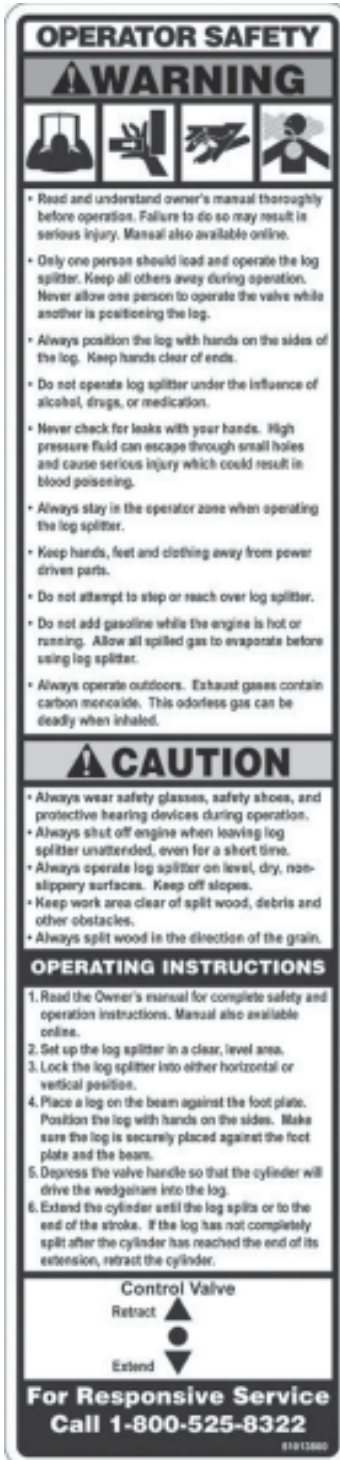

PART NUMBER: 52046200
LOCATION: TOP OF HYDRAULIC CYLINDER



PART NUMBER: 52055200
LOCATION: STRIPPER PLATE AND CYLINDER



PART NUMBER: 52024000
LOCATION: TOP OF A-FRAME/HITCH ASSEMBLY



IMPORTANT SAFETY INFORMATION

PREPARATION OF THE LOG

Both ends of the log should be cut as square as possible to help prevent the log from riding out of the splitter during operation. Do not split logs greater than 26 in. in length.

WORK AREA

NEVER operate the log splitter on slippery, wet, muddy or icy ground.

ONLY operate your log splitter on level ground. Operating on a slope could cause the log splitter to roll over or logs to fall off.

NEVER operate your log splitter in an enclosed area. Exhaust fumes contain carbon monoxide which can be deadly when inhaled.

NEVER attempt to move your log splitter over hilly or uneven terrain without a tow vehicle or adequate help.

ALWAYS block the wheels to prevent movement of the log splitter while in operation.

ONLY operate your log splitter in daylight or under good artificial light.

ALWAYS keep the work area clean. Remove split wood around your log splitter immediately so that you don't stumble over it.

OPERATION OF THE LOG SPLITTER

ONLY operate the log splitter from the operator zone.

KNOW how to stop the log splitter and disengage the controls before operating it.

NEVER place hands or feet between the log and splitting wedge during forward or reverse stroke. Serious injury or death could result.

NEVER straddle or step over the log splitter during operation.

NEVER reach or bend over the log splitter to pick up a log.

NEVER try to split two logs on top of each other.

NEVER try to cross split a second log.

NEVER allow one person to operate the valve while another is positioning the log.

NEVER attempt to load your log splitter when the ram or wedge is in motion.

ALWAYS use your hand to operate the control lever on the valve. **NEVER** use your foot, a rope or any extension device.

Shut off the engine even if you are leaving the log splitter for a short period of time.

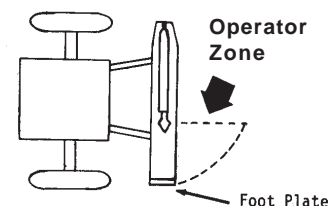



IMPORTANT SAFETY INFORMATION

REPAIR AND MAINTENANCE SAFETY

NEVER operate your log splitter when it is in poor mechanical condition or in need of repair.

Periodically check that all nuts, bolts, screws, hydraulic fittings and hose clamps are tightened.

NEVER alter your log splitter in any manner such as adding a rope or extension to the control lever or adding to the width or height of the wedge. Such alterations may cause your log splitter to be unsafe and will void the warranty.

Perform all recommended maintenance procedures before using your log splitter.

Replace all damaged or worn parts immediately.

ALWAYS check the level of hydraulic oil and engine oil before operation.

ALL replacement parts must meet manufacturer's specifications.

HYDRAULIC SAFETY

The hydraulic system of your log splitter requires careful inspection along with the mechanical parts. Be sure to replace frayed, kinked, cracked or otherwise damaged hydraulic hose and components.

NEVER check for leaks of hydraulic fluid with your hand. Fluid escaping from a small hole can be almost invisible. Escaping fluid under pressure can have sufficient force to penetrate skin causing serious personal injury or even death. Leaks can be detected by passing a piece of cardboard over the suspected leak and looking for discoloration.

ALWAYS seek professional medical attention immediately if injured by escaping hydraulic fluid. Serious infection or reaction can develop if proper medical treatment is not administered immediately.

ALWAYS be sure to relieve all pressure by shutting off the engine and moving the valve control handle back and forth should it become necessary to loosen or remove any hydraulic fitting.

NEVER adjust the hydraulic valve. The pressure relief valve on your log splitter is preset at the factory. Only a qualified service technician should perform this adjustment.



IMPORTANT SAFETY INFORMATION

TOWING SAFETY

ALWAYS check all local and state regulations regarding towing, licensing, and lights before towing your log splitter.

ALWAYS check before towing to make sure that the log splitter is correctly and securely attached to the towing vehicle and that the safety chains are secured to the hitch or bumper of the vehicle with enough slack to allow turning.

NEVER carry any cargo or wood on your log splitter.

NEVER allow anyone to sit or ride on your log splitter.

ALWAYS be careful when backing up with your log splitter in tow. It could jackknife.

ALWAYS allow for added length of your log splitter when turning, parking, crossing intersections and in all driving situations.

NEVER exceed 45 mph when towing your log splitter. Towing the log splitter at speeds higher than 45 mph could result in loss of control, damage to the equipment, serious injury or death. Adjust towing speed for terrain and conditions. Be extra cautious when towing over rough terrain especially railroad crossings.

ASSEMBLY INSTRUCTIONS

NOTE: This log splitter was partially assembled at the factory. Refer to the drawing and parts list should it become necessary to disassemble the unit for repair or replacement of parts.

STEP 1: Remove all the components from the crate. Inspect each piece for shipping damage. If any part is damaged, contact your dealer or delivering carrier.

STEP 2: Attach the four legs to the A-frame stand (18) using the 5/16 in. NC x 1-1/2 in. hex cap screws (28), 5/16 in. lockwashers (29) and the 5/16 in. hex nuts (30). Tighten.

STEP 3: Insert the draw pins (19) into the lower holes on the A-frame stand (18). Secure with 7/8 in. lockwashers (20) and 7/8 in. hex nuts (21). Tighten.

STEP 4: Stand the beam (1) on end. Check to see that it is stable. Line up the bracket holes on the A-frame stand (18) with the two ears on the beam (1) and insert the pivot pin (16). Secure with clip pin (17).

STEP 5: Insert the stabilizer pin (23) through the hole on the A-frame stand (18) from underneath. Secure with 7/8 in. lockwasher (24) and 7/8 in. hex nut (25).

STEP 6: Carefully lower the beam to the horizontal position. Be certain that the ground stand is securely in place. Put the lynch pin through the hole in the stabilizer pin (23) to hold the beam in place.

STEP 7: Attach the hydraulic fittings (13) provided in the hardware kit to the valve (14).

STEP 8: Back the tractor into position and slide the lift arms over the draw pins on the A-frame/stand (18). Secure with lynch pins (not provided). Attach the top link from the tractor to the clevis on the A-frame/stand (18) and secure with a top link pin and a lynch pin (not provided).

STEP 9: IMPORTANT: The tractor must be able to handle Category I or Category II three-point hitch implements and be equipped with a four-way valve (for double-acting cylinders) and hydraulic outlets.

The tractor owner's manual should be consulted for instructions on tractor operation, safety and auxiliary hydraulic systems pumping and return flow hookups.

Determine the easiest position to lock the tractor's valve lever in the operating position. Then locate the pressure and return ports with the valve locked in this position. Connect the hoses from the tractor to the log splitter with the flow from the pressure port entering on the "IN" side of the valve. The return flow to the tractor should come from the "OUT" side.

After connecting the hoses to the valve, the system should be energized by moving the tractor auxiliary valve in the direction to cause oil flow. Tie in place. Oil should flow in only one direction through the hydraulic valve. If the tractor auxiliary valve is moved to the wrong position, the log splitter relief valve will not operate and damage to the tractor system or log splitter could result.

The tractor hydraulic system should be capable of delivering 6 to 25 gpm of oil at 1500 to 2500 psi for adequate splitting force and speed. The tractor should have a cooling system to allow semi-continuous operation.

NOTE: Hoses to the tractor are **not** included. Specifications of the hoses and fittings supplied by the owner should be within recommended ranges of the tractor operating pressure.

STEP 10: Using the tractor three-point hitch, raise the log splitter to a convenient height and level with the top link. The log splitter may be operated in either the horizontal or vertical position. See illustration on page 9.

STEP 11: A closed spool kit is included in the hardware/hydraulic kit for converting open center valves to closed center. Instructions are included in the kit.

OPERATING INSTRUCTIONS



WARNING: Read and thoroughly understand all instructions and safety information before operating this log splitter. Failure to do so may cause serious injury or death. Do not allow anyone to operate this log splitter who has not read this manual. As with all power equipment, a log splitter can be dangerous if assembled or used improperly. Do not operate this log splitter if you have doubts or questions concerning safe operation. Call our customer service department at 1-800-525-8322 to address these concerns.

Si no entiende ingles, se prefiere que busque alguien que interprete las instrucciones para usted.

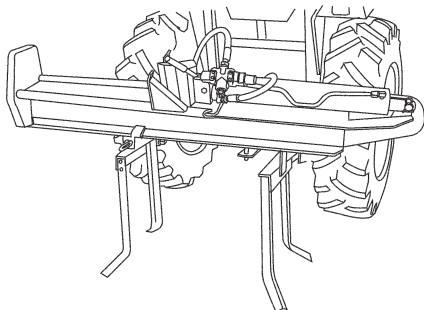

Log splitter quickly converts to the horizontal position. Just lower the beam on hinge and lock in place with lynch pin (22).



WARNING: See safety information related to operation of the log splitter on pages 1 through 5 of this manual. Make sure that you have the recommended personal protective equipment described on page 1.

- 1) Set up the log splitter in a clear, level area.
- 2) Place a log on the beam against the foot plate. Make sure the the log is securely on the foot plate and up against the beam.
- 3) Depress the valve handle so that the cylinder will drive the wedge into the log. Extend the cylinder until the log splits or to the end of its stroke. If the log has not completely split after the cylinder has reached the end of its extension, retract the cylinder.
IMPORTANT: Leaving the valve in the "actuate" position at the end of the stroke may damage the pump. Always use extra care when splitting logs with unsquare ends.

IMPORTANT: TO EXTEND THE LIFE OF THE HYDRAULIC CYLINDER, AVOID "BOTTOMING OUT" WEDGE PLATE TO THE FOOT PIECE. TO CONFORM WITH INDUSTRY SAFETY RECOMMENDATIONS, THE WEDGE STOPS 2 INCHES FROM THE END OF THE STROKE.



WARNING: TILT SLOWLY! DO NOT MOVE FROM VERTICAL TO HORIZONTAL POSITION UNLESS FRAME LEGS ARE SECURELY IN PLACE. TRACTOR LIFT ARMS COULD FALL RESULTING IN SERIOUS INJURY.

MAINTENANCE

- 1) With normal use the log splitter will not require any regular maintenance other than checking for loose bolts and the inspection of hoses and fittings.
- 2) If the wedge becomes dull or nicked, it can be removed and sharpened. Remove the 1/2 in. diameter bolt that connects the wedge to the cylinder. The hose from the valve may need to be removed. While the log splitter is in the horizontal position, loosen the hose clamp and disconnect the hose from the valve. Carefully lift the cylinder to allow the wedge to slide forward. The wedge can now be lifted off and sharpened.
- 3) See also Repair and Maintenance Safety on page 4 of this manual.
- 4) All replacement parts must meet manufacturer's specifications.

PARTS BREAKDOWN FOR MODEL NO. 2153304

REFERENCE NO.	PART NO.	DESCRIPTION	NUMBER REQUIRED
	2153304 (400197TS)	3-Point Hitch Vertical/Horizontal Log Splitter Complete	1
1	401414NY	Yellow Beam (6"x 9")	1
2	40141700	Wedge	1
3	O/L	1/2 in. NC x 3 in. Hex Cap Screw (Grade 5)	1
4	O/L	1/2 in. Lockwasher	1
5	O/L	1/2 in. NC Hex Nut	1
6	390118BC	4 in. x 24 in. Hydraulic Cylinder	1
7	O/L	Clip Pin	2
8	07073100	Cylinder Pin with Clips	1
10	39034700	1/2" Pipe to Steel Tube Fitting	2
11	39034600	1/2" Steel Tubing	1
13	39034300	1/2" NPT Nipple	1
14	390406A0	Auto-Return Valve	1
16	071022WC	5/8 in. x 6-1/4 in. Welded Hitch Pin with 3/32 in. Clip Pin	1
17	O/L	3/32 in. Clip Pin	2
18	400163CH	3-Point "A" Frame	1
19	*070208A0	7/8 in. Diameter Draw Pin	2
20	*O/L	7/8 in. Lockwasher	2
21	*O/L	7/8 in. NF Hex Nut	2
22	*07090400	1/4 in. Lynch Pin	1
23	*070801A0	7/8 in. Stabilizer Pin	1
24	*O/L	5/8 in. Lockwasher	1
25	*O/L	5/8 in. NF Hex Nut	1
26	400164CH	3-Point Leg for "A" Frame	4
28	*O/L	5/16 in. NC x 1 in. Hex Cap Screw (Grade 5)	8
29	*O/L	5/16 in. Lockwasher	8
30	*O/L	5/16 in. NC Hex Nut	8
31	390429A0	Control Handle for Valve	1
32	39043400	Chain Link for Valve Handle	1
33	39044200	Spring Cap for Valve	1
	39044300	Detent Assembly for Valve	1
35	39043500	Mounting Bracket for Valve	1
36	07042900	1/4" Clevis Pin	1
37	17111011	3/32" Straight Cotter Pin	1
	*390441E0	Closed Spool Kit	1
	*39031600	Hose Clamp	1
	*39031100	3/4-1/2" Reducer	2
	*401157AO	Hardware/Hydraulic Kit	1

O/L - Obtain locally. Common fasteners available through hardware and farm stores

3-POINT HITCH LOG SPLITTER

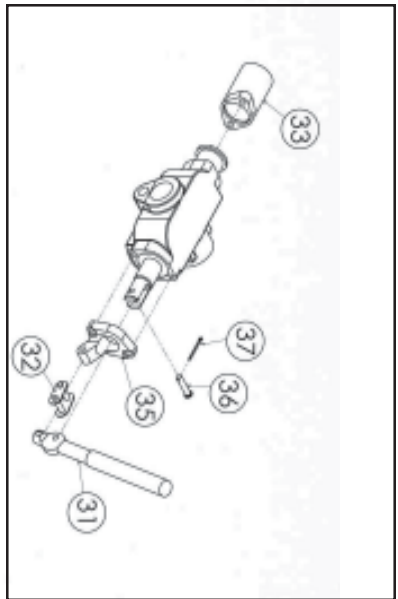
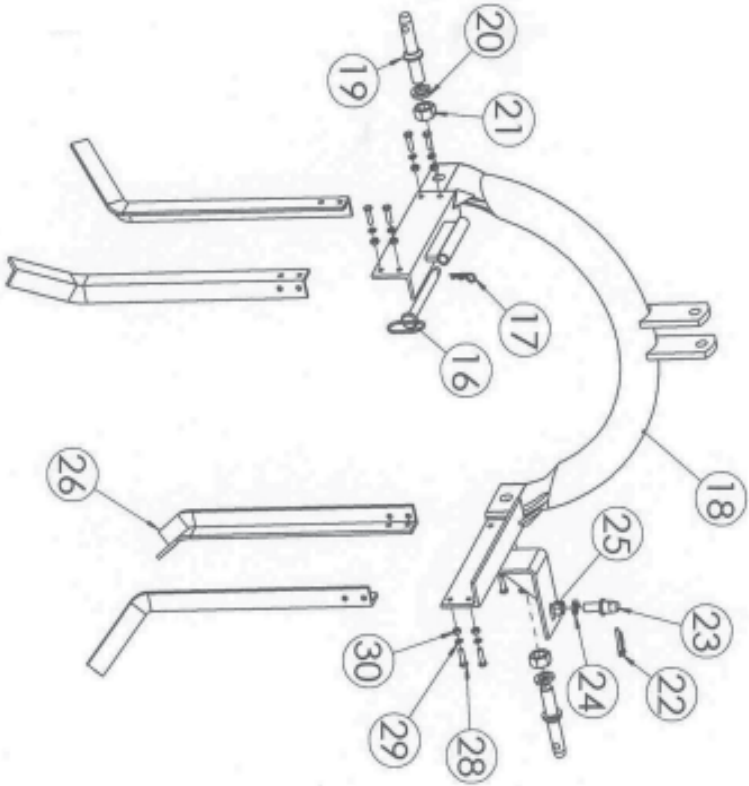
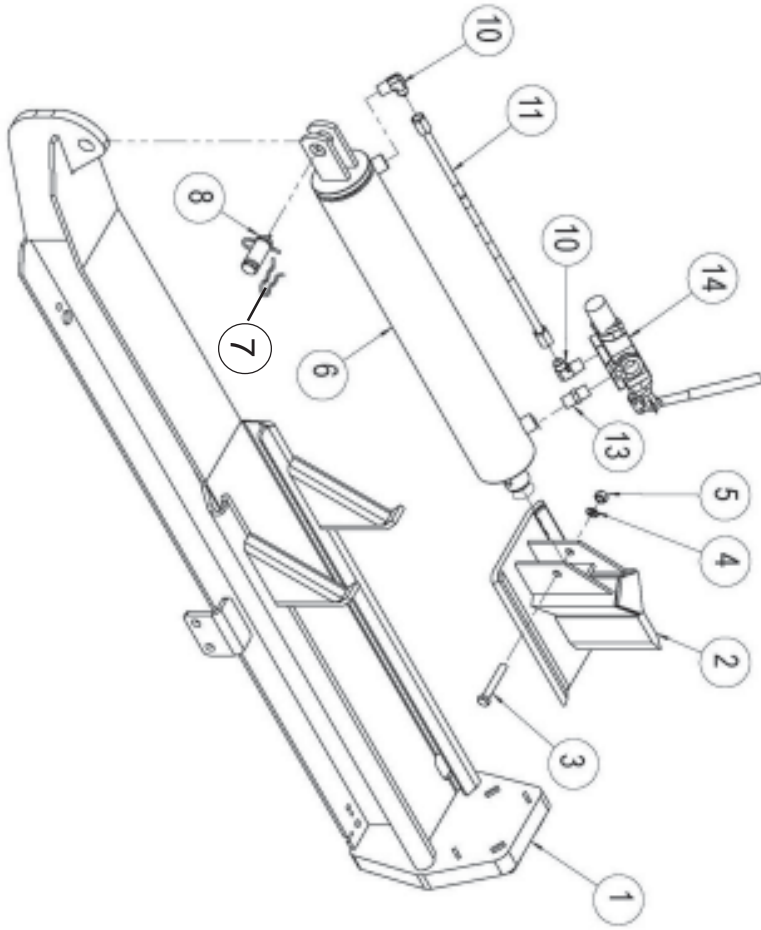

Valve Assembly

IMPORTANT NOTICE

We, the manufacturer, reserve the right to change the product and/or specifications in this manual without notification. The manual is for information usage only and the pictures and drawings depicted herein are for reference only.

==== **NOTES** ====

Warranty Repair and Service

Do not return this product to the store for warranty issues or repair. Call 1-800-525-8322 for the location of the nearest service center.

Record the information below for future reference.

Model No. _____

Serial No. _____

Date of Purchase _____

Place of Purchase _____

SPECIFICATIONS

Tractor Categories	1 and 2
Maximum Splitting Force	Depends on tractor*
Cycle Time	Depends on tractor*
Maximum Log Length	26"
Cylinder	4" diameter x 24" stroke
Valve	Auto-return
Beam Size	6" x 9"
Wedge	7" high with spreader wings
Hitch	Tractor 3-point
Height	42" horizontal 72" vertical
Width	22"
Length	72"
Shipping Weight	365 lbs.

*Splitting force is determined by cylinder size and tractor PSI. Cycle time depends on cylinder size and GPM's that the tractor produces. Tractor should ideally produce 8-15 GPM at 1500 to 2500 PSI Do not exceed 3200 PSI. See tables below for approximate splitting force and cycle time.

Splitting Force (tons)

Cylinder Size	1000 PSI	1500 PSI	2000 PSI	2500 PSI	3000 PSI	3500 PSI
3"	3.5	5.3	7.1	8.8	10.6	12.4
3-1/2"	4.8	7.2	9.6	12.0	14.4	16.8
4"	6.3	9.4	12.6	15.7	18.8	22.0
4-1/4"	7.1	10.6	14.2	17.7	21.3	24.8
4-1/2"	7.9	11.9	15.9	19.9	23.9	27.8
5"	9.8	14.7	19.6	24.5	29.5	34.3

Cycle Time (seconds)

Cylinder Size	5 GPM	10 GPM	15 GPM	20 GPM	25 GPM
3" x 24"	15.4	7.7	5.1	3.9	3.1
3-1/2" x 24"	21.8	10.9	7.3	5.4	4.4
4" x 24"	28.3	14.2	9.4	7.1	5.7
4-1/4" x 24"	32.4	16.2	10.8	8.1	6.5
4-1/2" x 24"	36.6	18.3	12.2	9.2	7.3
5" x 24"	45.0	22.5	15.0	11.3	9.0



CAUTION: This log splitter is designed for tractors with pressure ratings under 3200 psi. Warranty will be voided if used on tractors that exceed pressure settings of 3200 psi. Do not exceed the pressure rating of the cylinder and valve manufacturers



A brand of Special Products Co.
 15000 W. 44th Ave. Golden Colorado 80403
 303-279-5544 Toll Free USA 800-525-8322 Fax 303-278-3432
 Email: speeco@speeco.com Web: www.speeco.com