

# INSTALLATION INSTRUCTIONS

## EQUIPMENT REQUIRED:

WIRING ACCESS LOCATION: PU3

DRILL BITS:

HITCH REQUIRES 5/8" PIN AND CLIP IF STABILIZING PIN IS NOT INSTALLED.

WRENCHES: (TIGHTEN ALL FASTENERS WITH TORQUE WRENCH) 18mm, 3/4, 7/8

VEHICLE	HITCH NO.
CHEVROLET S-10 PICKUP	75051
GMC S-15 PICKUP	33053
GMC SONOMA PICKUP	
ISUZU HOMBRE	

DO NOT EXCEED LOWER OF  
TOWING VEHICLE MFR'S RATINGS OR

HITCH TYPE	MAX GROSS TRLR WT(LB)	MAX TONGUE WT(LB)
WEIGHT DISTRIBUTING	6000	750
WEIGHT CARRYING BALL MOUNT	3500	350

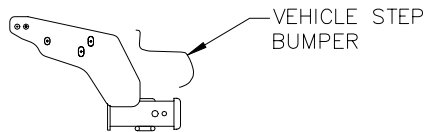

HITCH SHOWN IN PROPER POSITION

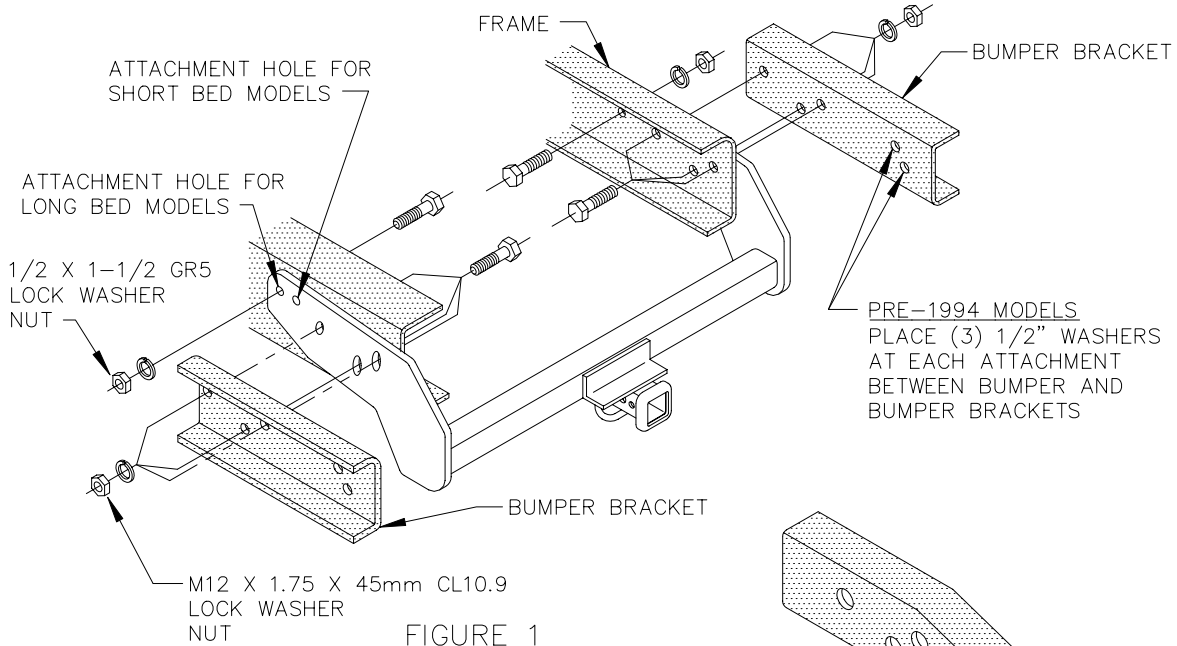

FIGURE 1

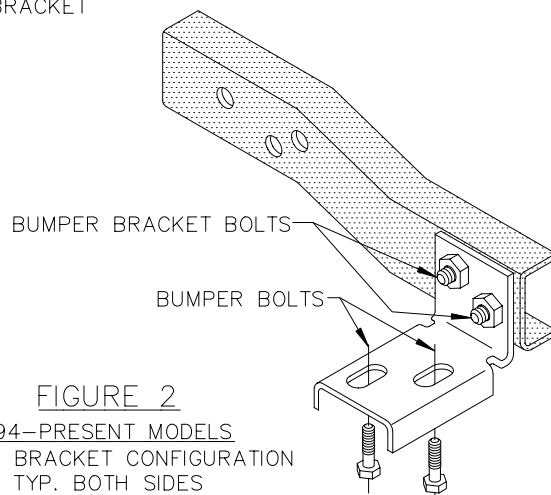
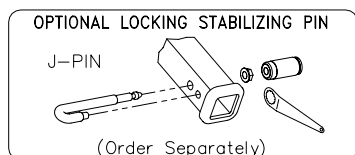

FIGURE 2

1994-PRESENT MODELS  
BUMPER BRACKET CONFIGURATION  
TYP. BOTH SIDES

1. REMOVE BUMPER, LEAVING BRACKETS ATTACHED TO FRAME. DISCONNECT BUMPER WIRING BEFORE REMOVING BUMPER.  
NOTE: PRE-1994 MODELS. BUMPER IS ATTACHED TO BUMPER BRACKETS BY TWO (2) HORIZONTAL BOLTS.  
1994-PRESENT MODELS. BUMPER IS ATTACHED TO BUMPER BRACKETS BY TWO (2) VERTICAL BOLTS. SEE FIGURE 2.
2. REMOVE BUMPER BRACKETS FROM FRAME. REMOVE BUMPER WIRING GUIDES FROM BUMPER BRACKETS.
3. MARK SPARE TIRE CARRIER 1/8" INBOARD OF OUTBOARD EDGE OF FRAME.
4. LOWER SPARE TIRE AND CUT OFF CARRIER ALONG LINE MARKED.  
NOTE: STEPS 3 & 4 NOT REQUIRED FOR LATER MODEL VEHICLES USING A CABLE STORAGE SYSTEM FOR SPARE TIRE.
5. POSITION RECEIVER ON FRAME AND LOOSELY RE-INSTALL BUMPER BRACKETS USING (3) M12 BOLTS AND FASTENERS PER SIDE. RECEIVER BRACKETS ARE SANDWICHED BETWEEN BUMPER BRACKETS AND FRAME.
6. PRE-1994 MODELS: REINSTALL BUMPER ON BUMPER BRACKETS WITH ORIGINAL BOLTS, USING THREE (3) 1/2" WASHERS AT EACH BOLT LOCATION AS SPACERS BETWEEN BRACKETS AND BUMPER. SEE FIG. 1.  
1994-PRESENT MODELS: REINSTALL BUMPER ON BUMPER BRACKETS WITH ORIGINAL BOLTS. SLOTS IN BUMPER BRACKET ALLOW FOR ADJUSTMENT.
7. TIGHTEN ALL BOLTS TO 75 LB.-FT.
8. RAISE SPARE TIRE BACK INTO POSITION AND SECURE. RE-CONNECT BUMPER WIRING.  
VEHICLES WITHOUT BUMPERS: SUBSTITUTE (6) 1/2" CONICAL WASHERS FOR LOCK WASHERS USED WITH THE M12 BOLTS. THE CONICAL WASHERS (1292-008) ARE NOT PROVIDED.

THIS PRODUCT COMPLIES WITH SAFETY SPECIFICATIONS AND REQUIREMENTS FOR CONNECTING DEVICES AND TOWING SYSTEMS OF THE STATE OF NEW YORK AND V.E.S.C. REGULATION V-5.

APPROX WEIGHT (LB.)	FASTENER KIT
37.5	01130-584

NOTE: Check hitch frequently, making sure all fasteners and ball are properly tightened. If hitch is removed, plug all holes in trunk pan or other body panels to prevent entry of water and exhaust fumes. A hitch or ball which has been damaged should be removed and replaced. Observe safety precautions when working beneath a vehicle and wear eye protection. Follow car maker's specs for maximum trailer weight and tongue weight. Do not cut access or attachment holes with a torch.

**TOWING PRODUCTS**  
Plymouth, Michigan