



Floating Pump and Filter with UV

ITEM #FUVFL

REMINDER
CALL 1-888-755-6750
BEFORE RETURNING TO STORE.



Questions, problems, missing parts? Before returning to your retailer, call our customer service department at 1-888-755-6750, 8 a.m.-6 p.m., EST, Monday-Friday, or email us at customer care@thepondboss.net. Or visit our website www.thepondboss.net.

PACKAGE CONTENTS

Part	Description	Quantity
A	Floating pump and filter	1
B	Waterspray nozzle	1
C	Waterbell nozzle insert	1
D	Trumpet nozzle insert	1
E	Lower fountain head nozzle	1
F	Pump barrier bag	1

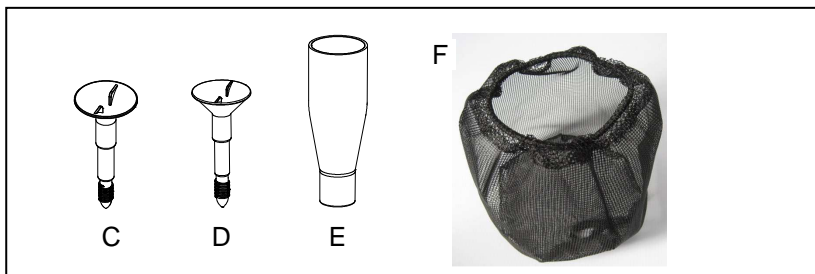
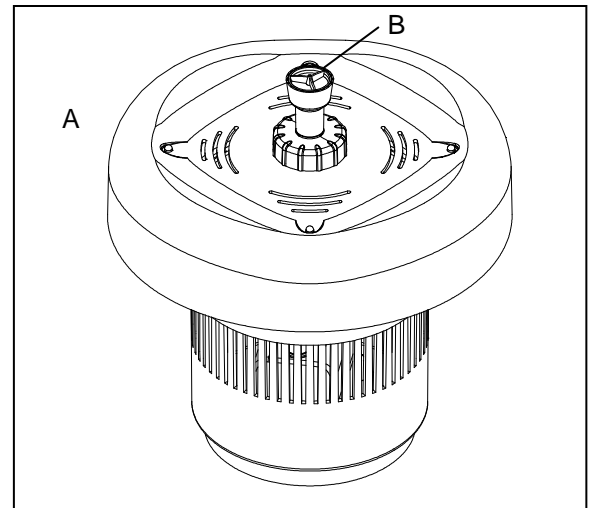

WARNINGS AND CAUTIONS

WARNING

- Risk of electrical shock. This unit is supplied with a grounding conductor and grounding-type attachment plug. To reduce the risk of electric shock, be certain that it is connected only to a properly grounded, grounding-type receptacle.
- Do not exceed 120 volts.
- Always disconnect unit from the power source before beginning any maintenance or work on the unit.
- Inspect cord for damage before installation and/or maintenance. Replace the entire pump assembly if damage is found.
- Do not remove the grounding pin from the power cord plug.
- Risk of electrical shock: This unit has not been investigated for use in swimming pools or marine areas.

CAUTION

- This unit has been evaluated for use with water only.
- Use a proper power source as indicated on the unit label.
- Keep the cord away from high temperatures or other heat sources.
- Do not pump heated liquids.
- Do not let the unit run dry. Unit must be completely submerged up to the flotation ring for proper operation and cooling.
- Operate in fresh water only. Avoid heavily chlorinated water and water with high pH levels.
- Do not lift the unit by its power cord.

CAUTION



PLEASE CALL 1-888-755-6750 BEFORE RETURNING TO THE STORE.
WWW.THEPONDBOSS.NET

- UV light may cause irritation to the skin and/or eyes. Avoid exposure.
- DANGER – ULTRAVIOLET RADIATION – disconnect power before replacing lamp.
- Prolonged or repeated exposure to UV light may have adverse physical effects including, severe damage to your skin and eyes. Seek immediate medical attention for overexposure to UV radiation.
- This light assembly has not been investigated for use in swimming pools or hot tubs.

PREPARATION

Before beginning assembly or operation of product, make sure all parts are present. Compare parts with package contents list and diagram above. If any part is missing or damaged, do not attempt to assemble, install or operate the product. Contact customer service for replacement parts.

- Estimated Assembly Time: 5 minutes
- Tools Required for Assembly: Philipshead screwdriver, string, rock.

OPERATION INSTRUCTIONS

1. Choose a fountain head for the desired water effect, and assemble your choice as shown in Fig. 1.

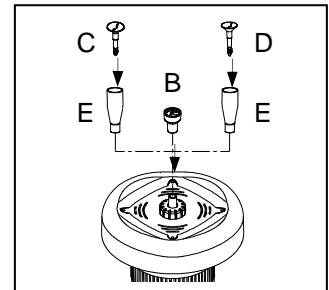

Fig. 1

1. Run the cord through the hole in the bottom of pumpshield™, then secure the pump barrier bag to the floating pump and filter with UV assembly. Hang the string to the hook on brace. Fig. 2



Fig. 2

2. If desired, anchor the fountain in the pond using a heavy object (such as a rock) and some string. Cut a length of string slightly longer than the depth of the pond. Tie one end of the string to the anchor and the other end to the ring at the bottom of the float. Fig. 3

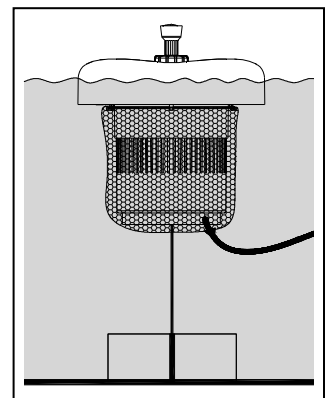

Fig. 3



PLEASE CALL 1-888-755-6750 BEFORE RETURNING TO THE STORE.
WWW.THEPONDBOSS.NET

- Place the unit into the water and connect to a proper power source. Fig. 4

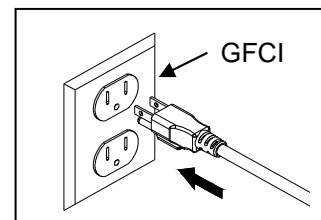

Fig. 4

DISASSEMBLY PROCEDURE

In order to insure optimal operation of the Floating Pump and Filter with UV, the following procedures should be performed periodically. When the performance of the water flow through the fountain head is reduced – it is an indication that cleaning of the unit is needed.

- Unplug the power cord, and then carefully remove the Floating Pump and Filter assembly from the pond. Fig. 5

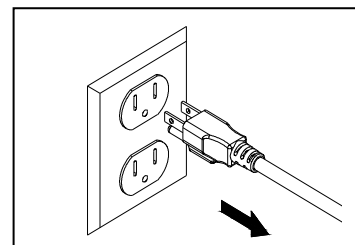

Fig. 5

- Remove the string from the hook then remove the pumpshield™ from floating pump and filter with UV assembly. Clean the pumpshield™ then install on to the floating pump and filter with UV assembly. Test the unit and inspect the performance. Fig. 6

NOTE: If the unit performance is still unsatisfactory, unplug the unit and proceed to step 3.



Fig. 6

- Turn the Floating Pump and Filter assembly upside down. Remove the locking screw. Fig. 7

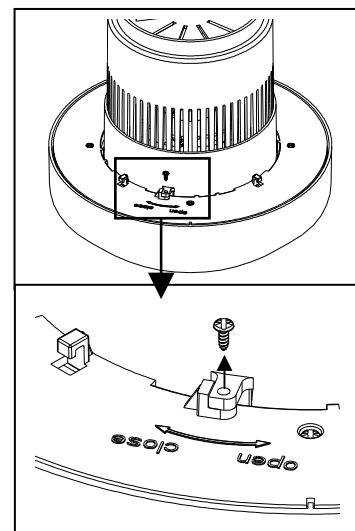

Fig. 7



PLEASE CALL 1-888-755-6750 BEFORE RETURNING TO THE STORE.
WWW.THEPONDBOSS.NET

4. Remove the fountain head and the top locking nut. Then remove the top cover. Fig. 8

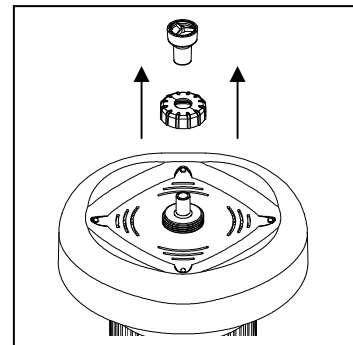

Fig. 8

5. Twist the top section counterclockwise. Then pull the top section from the lower. Unscrew the wire connector that connects the top section to the rest of the unit. Fig. 9

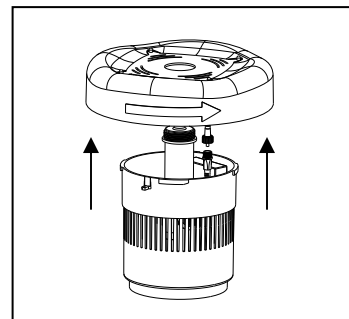

Fig. 9

6. Lift the pump and UV light assembly up from the fountain. NOTE: In order to extract the pump and UV light assembly from the flotation basket, the main power cord must be fed up through the bottom of the flotation basket. Fig. 10

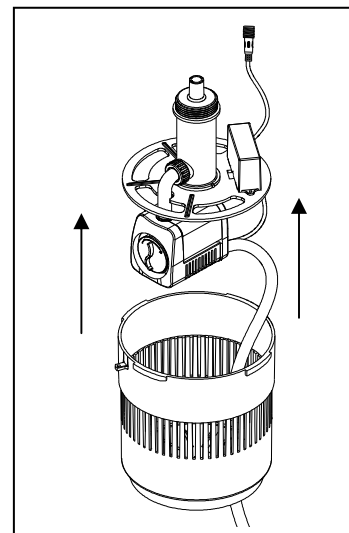

Fig. 10

7. Remove the pump, unscrew the wire connector that connects the UV light assembly to pump. Fig. 11

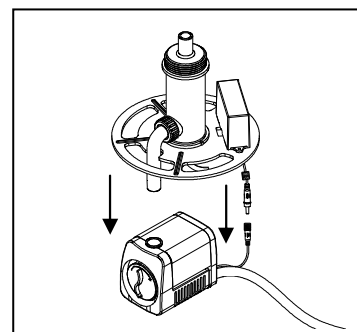

Fig. 11



**PLEASE CALL 1-888-755-6750 BEFORE RETURNING TO THE STORE.
WWW.THEPONDBOSS.NET**

8. Disassemble the pump, clean parts of the pump in warm, soapy water then reassemble the pump. Fig. 12

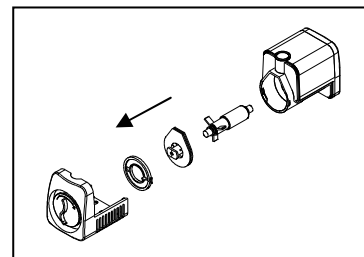

Fig. 12

9. Remove the locking nut by turning it counterclockwise then pulling it away from the light housing. Then remove UV bulb assembly by gently pulling on lamp holder. Be careful to pull assembly straight out so as not to damage the UV assembly. Fig. 13

NOTE: After removing the UV assembly, flush the inside of the light housing with water to clear out any debris.

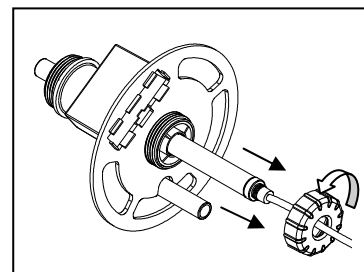

Fig. 13

10. Note: In the unlikely event the UV bulb needs replacing, remove glass tube by pulling straight apart by holding the base of the lamp. Gently pull bulb straight apart from the bulb socket and insert the replacement bulb in the reverse manner careful not to bend the wires at the stem of the bulb. Fig. 14

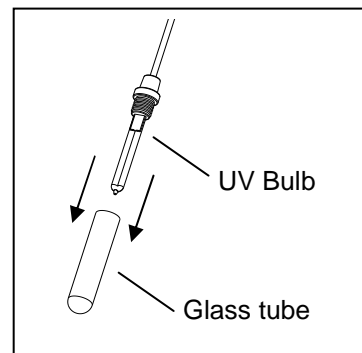

Fig. 14

11. Clean the exterior of the UV glass tube with warm soapy water. Fig. 15

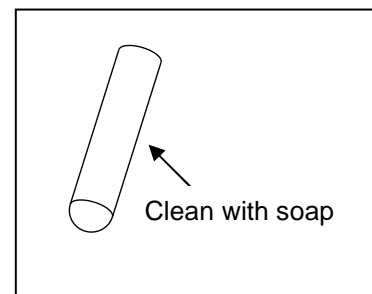

Fig. 15

12. Reassemble all of the components (Notes: Don't forget connect the low voltage power cables), place the unit into the water and connect to a proper power source. Fig. 16

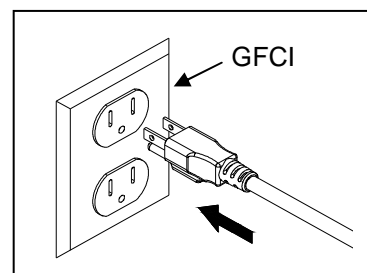

Fig. 16



**PLEASE CALL 1-888-755-6750 BEFORE RETURNING TO THE STORE.
WWW.THEPONDBOSS.NET**

CARE AND MAINTENANCE

- General
 - A visible drop in waterflow or increased algae in the pond is your indication that filter pad, pump, and/or UV clarifier portion of the unit require cleaning.
 - Before attempting to disassemble the unit or clean the pump, UV clarifier or any portion of the unit, always disconnect the unit from the power source.
 - Disassemble the unit in accordance with the Disassembly Procedure section of this instruction sheet.
- Cleaning the Pump
 - Insure the pump is disconnected from all other components comprising the unit.
 - Inspect the pump by removing the front screen and impeller assembly and clean parts of the pump and clean in warm, soapy water.
 - Reassemble the pump and reposition and connect the low voltage power cables

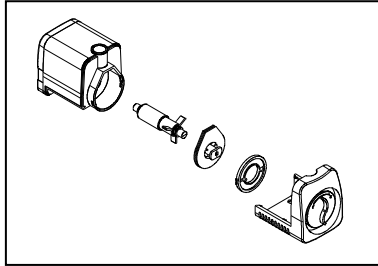

Fig. 17

To maximize the performance of the UV clarifier portion of the unit, periodically disassemble the unit to clean dirt and debris from the exterior of the glass tube and reflector located in the lamp housing.

IMPORTANT NOTE:

Be sure that the entire unit is completely dry and gaskets are properly seated when reassembling the UV clarifier.

Failure to do so will result in water leakage, which can cause damage to the light unit.

1. Disconnect the UV light from the outlet. Be sure to allow sufficient time for the light to cool before disassembling the light.
2. Unscrew the locking ring, and pull out the light unit.
3. Carefully pull out the glass tube holder by twisting and then pull out.
4. Use warm, soapy water to clean the glass tube. Be sure to use biodegradable soap.
5. Reassemble the UV clarifier, and be sure that all gaskets and o-rings are seated properly.

TROUBLESHOOTING

If the LED lights fail to operate:

- Check to make sure the power cord is plugged in and the light is getting power and the unit is getting power.

If the UV Clarifier fails to operate:

- Check bulb to make sure that it has not burned out. Replace the bulb as necessary or after every season. Bulbs are available by calling the customer service department.

If the pump fails to operate:

- Check to make sure the power cord is plugged in, the pump is getting power and the pump is fully submerged.
- Remove the inlet screen and/or pump cover, and impeller housing to expose the impeller. Turn the impeller to ensure that it is not broken or jammed.

If the performance of the pump is not satisfactory or the pump does not flow evenly:

- Check to make sure the pump is completely submerged in water.
- Check to make sure the impeller, filter pad and the housing are clean clear of debris.
- Check the pump outlet and any tubing, fountains, spitters etc. for kinks or obstructions.
- Adjust flow control.



PLEASE CALL 1-888-755-6750 BEFORE RETURNING TO THE STORE.
WWW.THEPONDBOSS.NET

REPLACEMENT PARTS LIST

For replacement parts, call our customer service department at 1-888-755-6750, 8 a.m.-6 p.m., EST, Monday-Friday, or email us at customer@thepondboss.net.

Part	Description
B	Waterspray nozzle
C	Waterbell nozzle insert
D	Trumpet nozzle insert
E	Lower fountain head nozzle
F	pumpshield™
G	Flow control knob
H	Front cover
I	Locking ring
J	Impeller cover
K	O-ring
L	Shaft support
M	Washer
N	Shaft
O	Impeller assembly
P	Float (upper)
Q	Float (lower)
R	Screw
S	Brace
T	Plug seal
U	Lamp housing
V	Locking nut
W	Lamp holder
X	Small locking nut
Y	Inlet
Z	Foil reflector
A1	Glass tube
B1	UV bulb

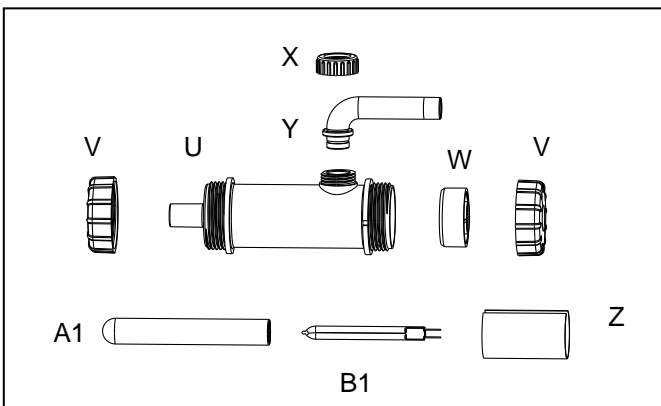
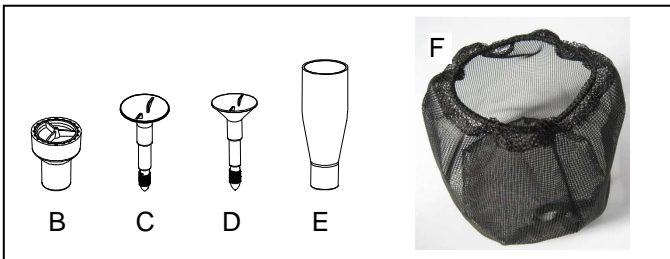
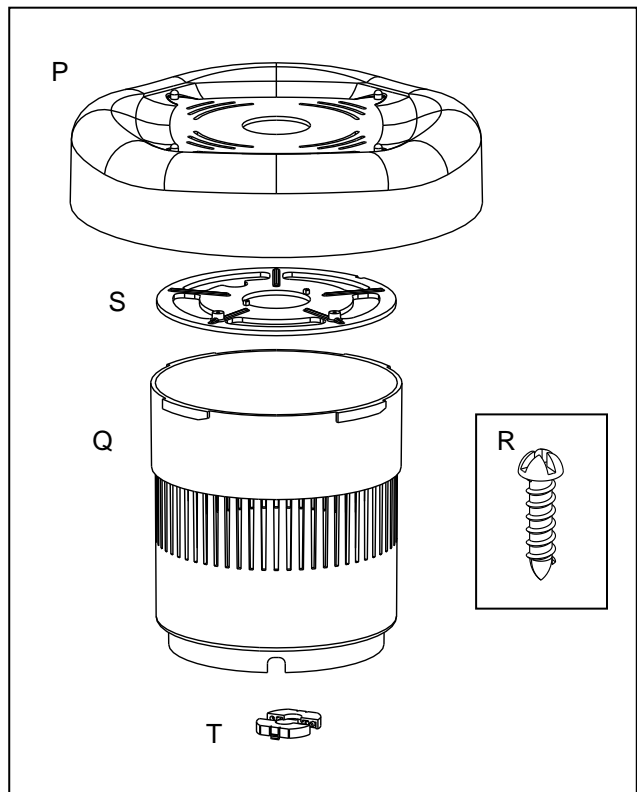
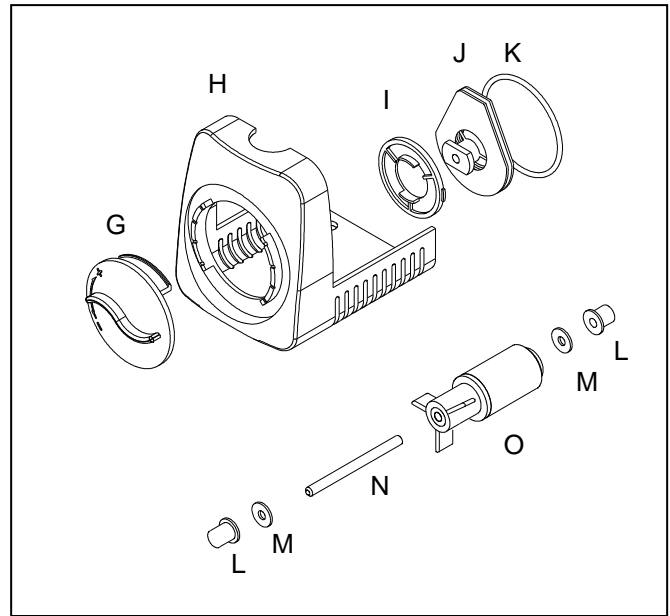

Printed in China



PLEASE CALL 1-888-755-6750 BEFORE RETURNING TO THE STORE.
WWW.THEPONDBOSS.NET

LIMITED WARRANTY

All pumps and electrical products are warranted to the user against defective material and workmanship, under normal working conditions. This warranty period begins on the date of purchase by the original purchaser.

Unless otherwise specified all pond boss® electrical products are warranted to the user against defective material and workmanship, under normal working conditions for 1 year from the date of purchase.

- Pond and Waterfall pumps are warranted for 3 years.
- All pond boss® liners are warranted to the user against defective workmanship, under normal working conditions for 20 years from the date of purchase.
- All other pond boss® products are warranted to the user against defective material and workmanship, under normal working conditions for 90 days.

Application

Warranty covers only properly installed and maintained units. Any damage to the cord or modification to the unit will invalidate the warranty. Pump warranty is limited to applications pumping fresh water in a pond or fountain only. Other liquid applications or extreme temperature uses must be approved in writing by the manufacturer. Receipt and product date code are required for warranty claims.

Warranty Claim

Warranty claims must be made by calling customer service (at 1-888-755-6750). If the item is determined to be defective, you will be given authorization to return the defective part(s), freight pre-paid, along with proof of purchase.

Disposition

The manufacturer will make a good faith effort for prompt disposition regarding all warranty claims. Returned product will be inspected to determine cause of failure before warranty is applied. Warranty does not cover any costs associated with the shipping, handling, installation or removal of products or parts subject to this warranty. For products damaged in transit, a claim should be filed with the carrier.

Disclaimer

Any oral statements made about the product by the seller, the manufacturer, the representatives, or any other parties do not constitute warranties, should not be relied upon by the user, and are not part of the contract for sale. The seller's and manufacturer's only obligation, and buyer's only remedy shall be for the manufacturer to either replace and/or repair at the manufacturer's sole discretion, the product as described above. Neither seller nor the manufacturer shall be liable for injury, loss or damages for lost profits, lost sales, injury to person or property, or any other incidental or consequential loss arising from any cause whatsoever, no matter whether based upon warranty, contract, negligence or other misuse, and the buyer and user agree that no other remedy shall be available to them. Before using, the buyer and user shall determine the suitability of the product for the intended use, and assume all risk and liability whatsoever in connection therewith. The warranty and remedy described in this limited warranty is an exclusive warranty and remedy in lieu of any other warranty or remedy expressed or implied. All other warranties and remedies are hereby expressly excluded, including but not limited to any implied warranty of merchantability of fitness for any particular purpose. This warranty gives the buyer and user specific legal rights, and buyer and user may also have other rights which vary from state to state. Some states do not allow exclusions or limitations of incidental or consequential damages, so the above limitations or exclusions may not apply to you.

REMINDER
CALL 1-888-755-6750
BEFORE RETURNING TO STORE.



PLEASE CALL 1-888-755-6750 BEFORE RETURNING TO THE STORE.
WWW.THEPONDBOSS.NET