

INSTALLATION INSTRUCTIONS

VEHICLE
**FORD SUPER DUTY
 F-SERIES TRUCKS**

HITCH NO.
 41922
 96922

EQUIPMENT REQUIRED:

WIRING ACCESS LOCATION: PU1, PU2

DRILL BITS:

HITCH REQUIRES 5/8" PIN AND CLIP IF STABILIZING PIN IS NOT INSTALLED.

WRENCHES: (TIGHTEN ALL FASTENERS WITH TORQUE WRENCH) 13/16, 7/8

DO NOT EXCEED LOWER OF
 TOWING VEHICLE MFR'S RATINGS OR

HITCH TYPE ▼	MAX GROSS TRLR WT(LB)	MAX TONGUE WT(LB)
WEIGHT DISTRIBUTING	12,000	1200
WEIGHT CARRYING BALL MOUNT	10,000	1000

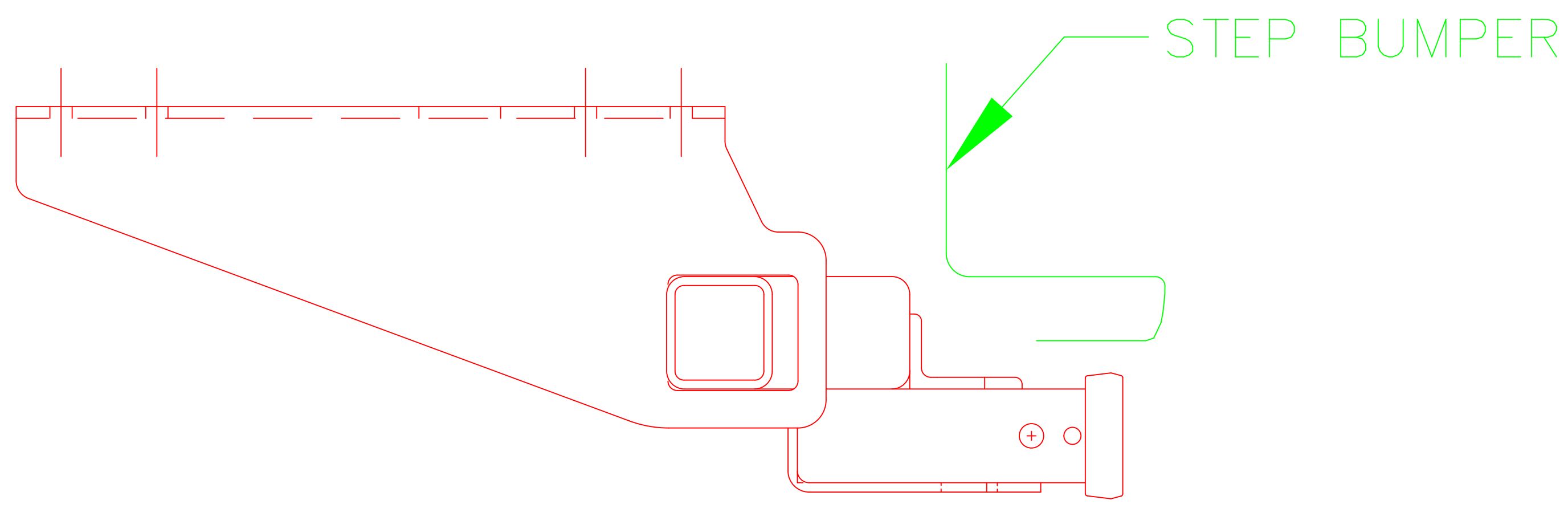

HITCH SHOWN IN PROPER POSITION

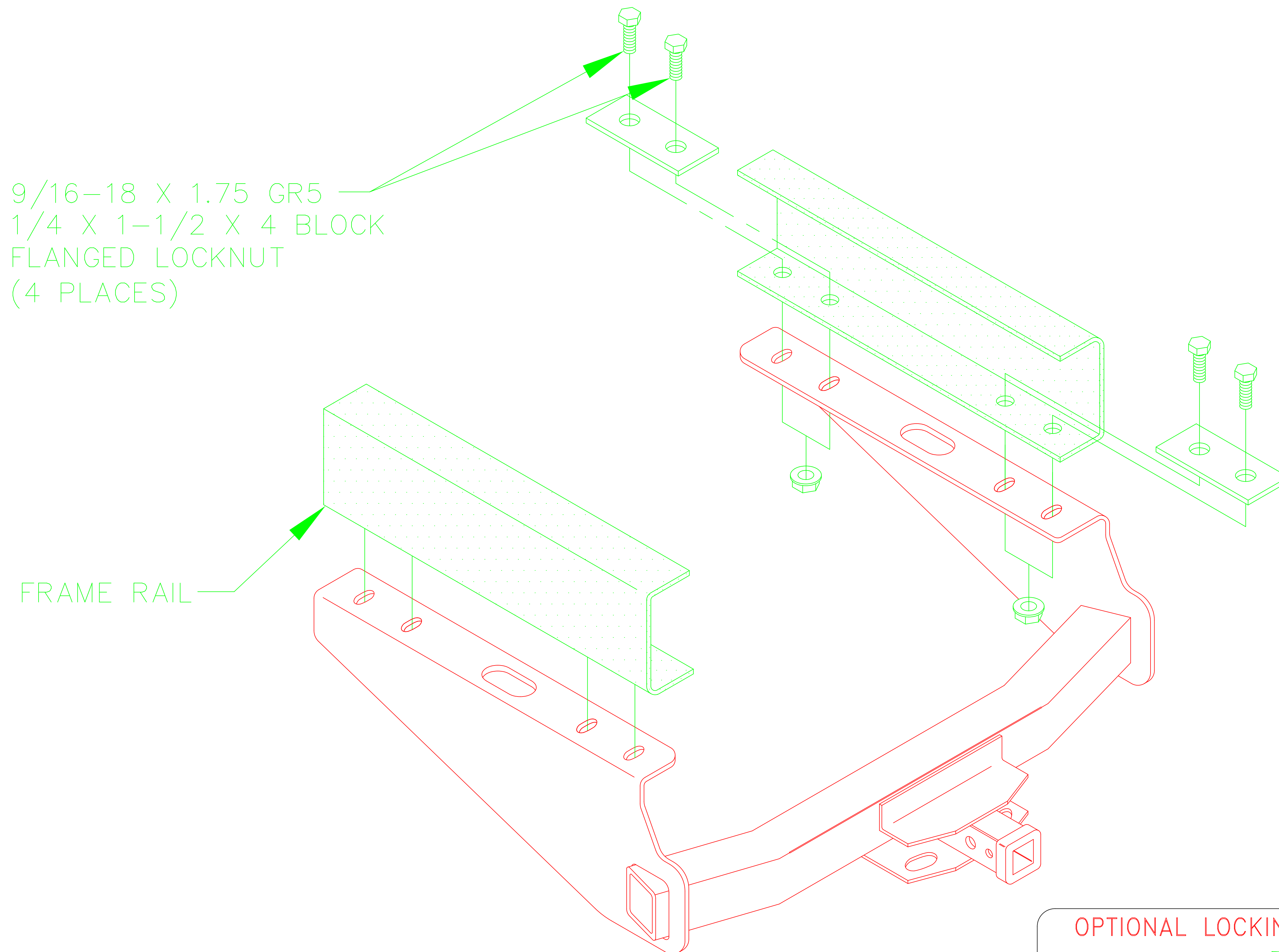

OPTIONAL LOCKING STABILIZING PIN

J-PIN

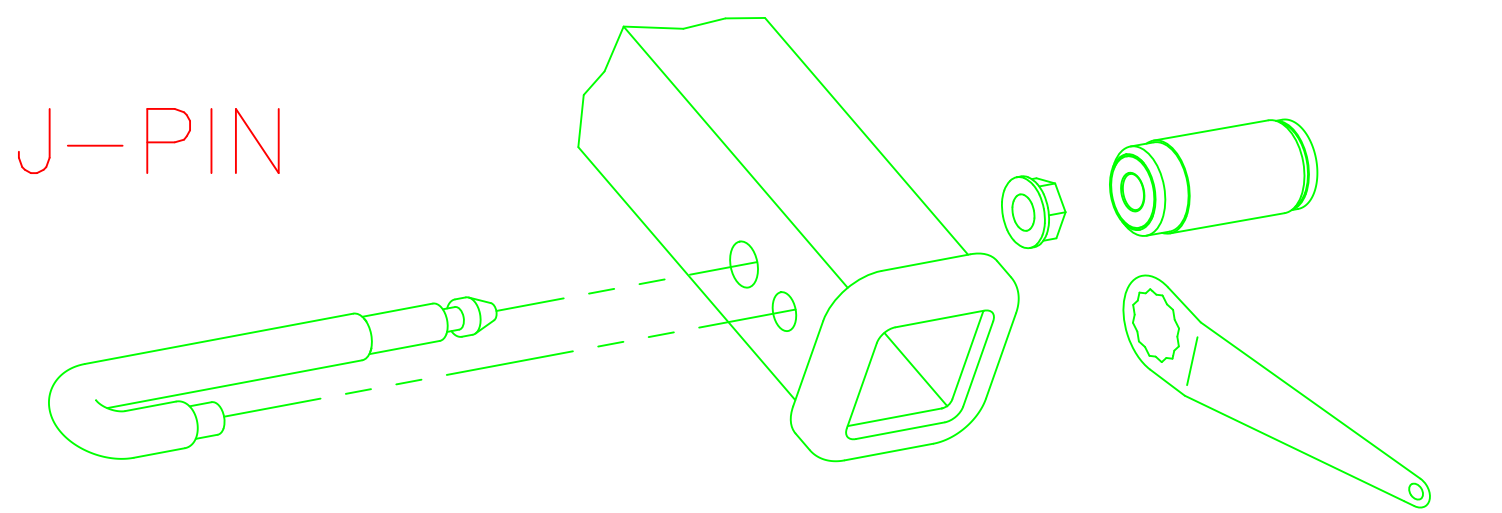

Part No. 7651 (Order Separately)

NOTE: DUE TO VEHICLE AND TIRE SIZE VARIATION SPARE TIRE MAY HAVE TO BE LOOSENED TO INSTALL HITCH.

1. SCRAPE WAX COATING OFF OF FRAME RAILS AROUND THE EIGHT ATTACHMENTS.
2. RAISE HITCH INTO POSITION AND INSTALL FASTENERS AS SHOWN ABOVE.

TIGHTEN ALL 9/16 GR5 FASTENERS TO 110 LB.-FT.

THIS PRODUCT COMPLIES WITH SAFETY SPECIFICATIONS AND REQUIREMENTS FOR CONNECTING DEVICES AND TOWING SYSTEMS OF THE STATE OF NEW YORK, V.E.S.C. REGULATION V-5 AND SAE J684.

APPROX WEIGHT (LB.)

65

FASTENER KIT

01131-052

NOTE: Check hitch frequently, making sure all fasteners and ball are properly tightened. If hitch is removed, plug all holes in trunk pan or other body panels to prevent entry of water and exhaust fumes. A hitch or ball which has been damaged should be removed and replaced. Observe safety precautions when working beneath a vehicle and wear eye protection. Follow car maker's specs for maximum trailer weight and tongue weight. Do not cut access or attachment holes with a torch.