

INSTALLATION INSTRUCTIONS

VEHICLE
MAZDA PROTEGE 5

EQUIPMENT REQUIRED:

WIRING ACCESS LOCATION: PC1, PC2

DRILL BITS: NONE

HITCH REQUIRES 1/2" PIN AND CLIP

WRENCHES: (TIGHTEN ALL FASTENERS WITH TORQUE WRENCH) 14mm, 11/16

2000 LB MAX GROSS TRAILER WT
200 LB MAX TONGUE WEIGHT
DO NOT EXCEED TOWING VEHICLE RATINGS

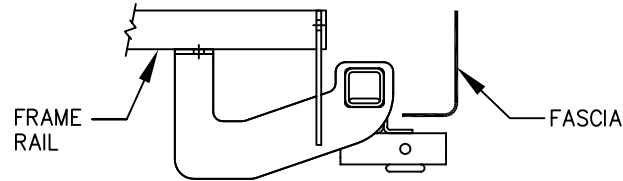

HITCH SHOWN IN PROPER POSITION

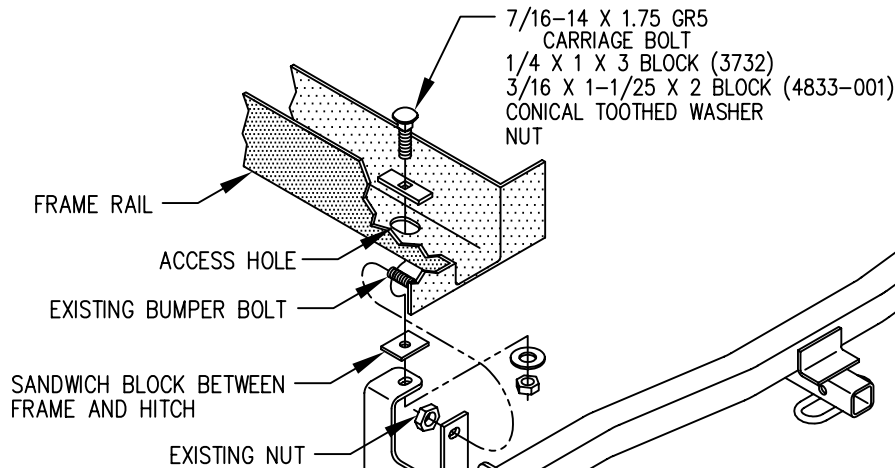

1. LOWER VEHICLE EXHAUST.
2. REMOVE TWO (2) BUMPER NUTS.
3. INSTALL CARRIAGE BOLT AND BLOCK (3732) THRU ACCESS HOLE IN FRAME.
4. RAISE HITCH INTO POSITION ON EXISTING BUMPER BOLTS WITH BLOCK (4833-001) BETWEEN FRAME AND HITCH.
5. INSTALL HEXNUTS ON EXISTING BUMPER BOLTS.
6. INSTALL CONICAL WASHERS AND NUTS ONTO CARRIAGE BOLTS.
7. REINSTALL VEHICLE EXHAUST.

TIGHTEN ALL M10 CL8.8 FASTENERS TO 38 LB-FT.

TIGHTEN ALL 1/2 GR5 FASTENERS TO 75 LB-FT.

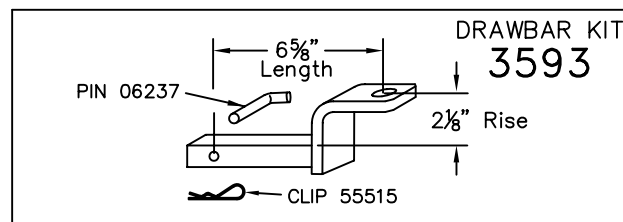

USE ONLY THE DRAWBAR SHOWN FOR CORRECT BUMPER CLEARANCE AND HEIGHT.
DRAWBAR MUST BE USED IN THE RISE POSITION ONLY.

THIS PRODUCT COMPLIES WITH SAFETY SPECIFICATIONS AND REQUIREMENTS FOR CONNECTING DEVICES AND TOWING SYSTEMS OF THE STATE OF NEW YORK, V.E.S.C. REGULATION V-5 AND SAE J684.

APPROX WEIGHT (LB.)

24

FASTENER KIT

F24714

NOTE: Check hitch frequently, making sure all fasteners and ball are properly tightened. If hitch is removed, plug all holes in trunk pan or other body panels to prevent entry of water and exhaust fumes. A hitch or ball which has been damaged should be removed and replaced. Observe safety precautions when working beneath a vehicle and wear eye protection. Follow car maker's specs for maximum trailer weight and tongue weight. Do not cut access or attachment holes with a torch.

TOWING PRODUCTS
Plymouth, Michigan