

INSTALLATION INSTRUCTIONS

EQUIPMENT REQUIRED:

WIRING ACCESS LOCATION: PC1, PC2

DRILL BITS:

HITCH REQUIRES 1/2" PIN AND CLIP

WRENCHES: (TIGHTEN ALL FASTENERS WITH TORQUE WRENCH) 9/16, 11/16

VEHICLE	HITCH NO.
CADILLAC SEVILLE	36243
	90043
	06617

FASCIA TRIMMING REQUIRED. OBTAIN VEHICLE OWNER APPROVAL BEFORE CUTTING.

3500 LB MAX GROSS TRAILER WT
300 LB MAX TONGUE WEIGHT
DO NOT EXCEED TOWING VEHICLE RATINGS

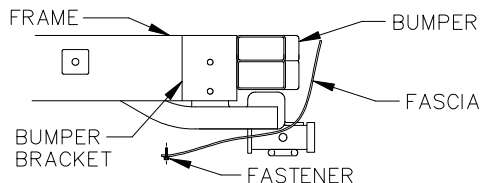

HITCH SHOWN IN PROPER POSITION

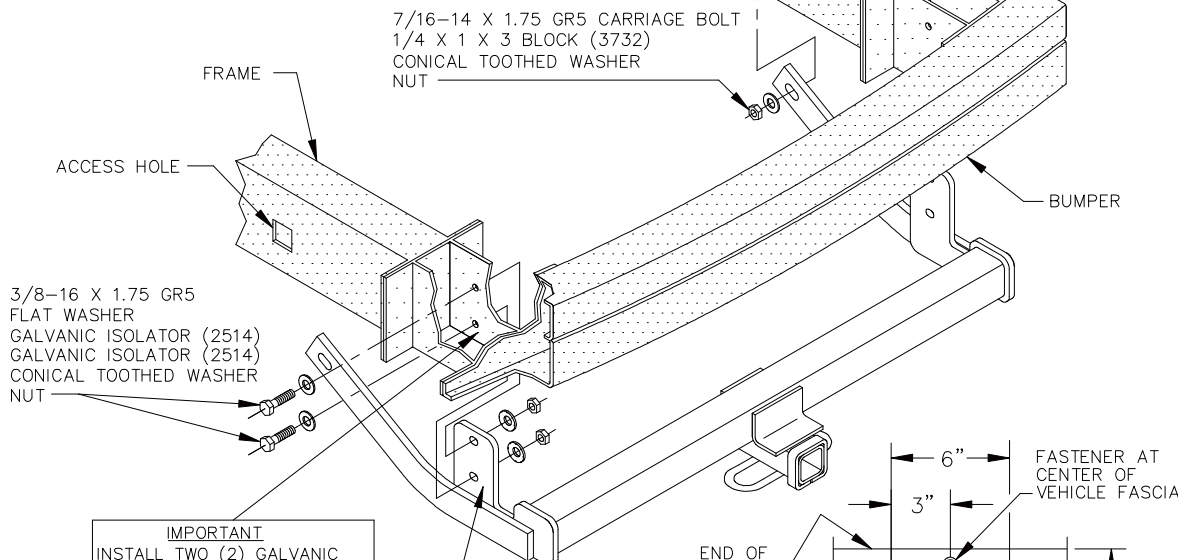

3/8-16 X 1.75 GR5
FLAT WASHER
GALVANIC ISOLATOR (2514)
GALVANIC ISOLATOR (2514)
CONICAL TOOTHED WASHER
NUT

IMPORTANT
INSTALL TWO (2) GALVANIC ISOLATOR SHIELDS (2514) PER BUMPER MOUNTING TAB. ISOLATOR SHIELDS MUST BE PLACED BETWEEN FLATWASHER AND ALUMINUM BRACKET.

IMPORTANT
INSTALL TWO (2) GALVANIC ISOLATOR SHIELDS (2514) PER BUMPER MOUNTING TAB. ISOLATOR SHIELDS MUST BE PLACED BETWEEN HITCH AND ALUMINUM BRACKET.

FIGURE 1

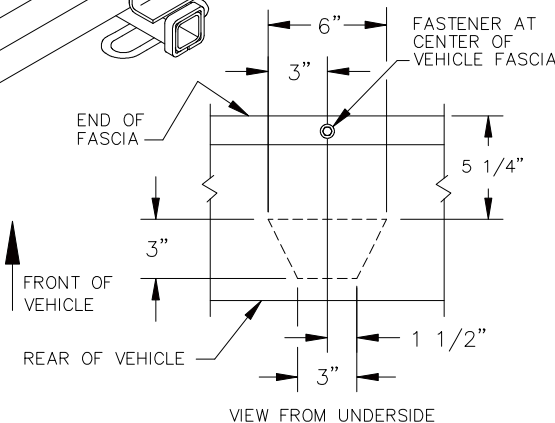

VIEW FROM UNDERSIDE

FIGURE 2

1. CUT HOLE FOR RECEIVER IN FASCIA AS SHOWN IN FIGURE 2.
2. DETACH VEHICLE FASCIA AT THREE (3) UNDERSIDE ATTACHMENT POINTS.
3. DETACH VEHICLE EXHAUST SYSTEM FROM REAR MOST LEFT AND RIGHT EXHAUST HANGERS.
4. PULL VEHICLE FASCIA AWAY FROM VEHICLE AND RAISE HITCH INTO POSITION. RECEIVER TUBE MUST EXTEND THROUGH HOLE CUT IN FASCIA.
5. INSTALL FASTENERS AS SHOWN IN FIGURE 1, FISHWIRING MAY EASE INSTALLATION OF CARRIAGE BOLTS.
6. REATTACH EXHAUST HANGERS AND FASCIA.

TIGHTEN 3/8 GR5 FASTENERS TO 31 LB.-FT.
TIGHTEN 7/16 GR5 FASTENERS TO 50 LB.-FT.

<p>DESIGNED FOR USE WITH</p> <p>PIN 2210</p> <p>CLIP 2209</p>	<p>DRAWBAR REPLACEMENT KIT (INCLUDES PIN & CLIP)</p> <p>36051 ZINC</p> <p>36052 CHROME</p> <p>NOTE: REPLACEMENT DRAWBAR AVAILABLE ONLY IN KIT. PINS & CLIPS AVAILABLE SEPARATELY.</p>
<p>36001 ZINC</p> <p>DRAWBAR</p> <p>36002 CHROME</p>	

USE ONLY THE DRAWBAR SHOWN FOR CORRECT BUMPER CLEARANCE AND HEIGHT.
REMOVE DRAWBAR WHEN NOT TOWING
TO PROTECT DRAWBAR OPENING IN HITCH WHEN NOT TOWING,
INSERT COVER #2211 (PURCHASED SEPARATELY).

THIS PRODUCT COMPLIES WITH SAFETY SPECIFICATIONS AND REQUIREMENTS FOR CONNECTING DEVICES AND TOWING SYSTEMS OF THE STATE OF NEW YORK AND V.E.S.C. REGULATION V-5.

APPROX WEIGHT (LB.)	24	FASTENER KIT NO.	1131-012
---------------------	----	------------------	----------

NOTE: Check hitch frequently, making sure all fasteners and ball are properly tightened. If hitch is removed, plug all holes in trunk pan or other body panels to prevent entry of water and exhaust fumes. A hitch or ball which has been damaged should be removed and replaced. Observe safety precautions when working beneath a vehicle and wear eye protection. Follow car maker's specs for maximum trailer weight and tongue weight. Do not cut access or attachment holes with a torch.

