

INSTALLATION INSTRUCTIONS

EQUIPMENT REQUIRED: LONG SOCKET EXTENSION
 WIRING ACCESS LOCATION: SUV4
 DRILL BITS:
 HITCH REQUIRES 1/2" PIN AND CLIP.
 WRENCHES: (TIGHTEN ALL FASTENERS WITH TORQUE WRENCH) 15mm, 14mm

VEHICLE
 CHEVROLET ASTRO VAN
 GMC SAFARI VAN
 STANDARD AND EXTENDED

3500 LB MAX GROSS TRAILER WT
 300 LB MAX TONGUE WEIGHT
 DO NOT EXCEED TOWING VEHICLE RATINGS

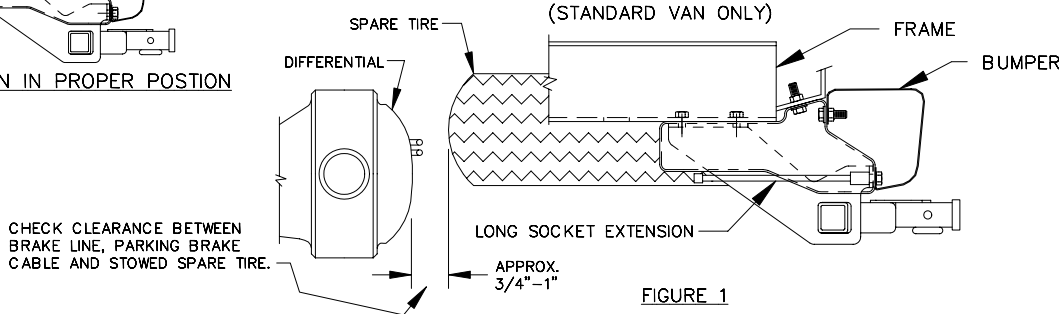
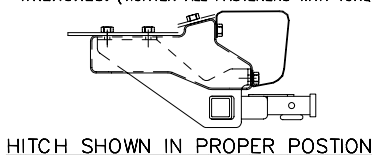

CHECK CLEARANCE BETWEEN BRAKE LINE, PARKING BRAKE CABLE AND STOWED SPARE TIRE.

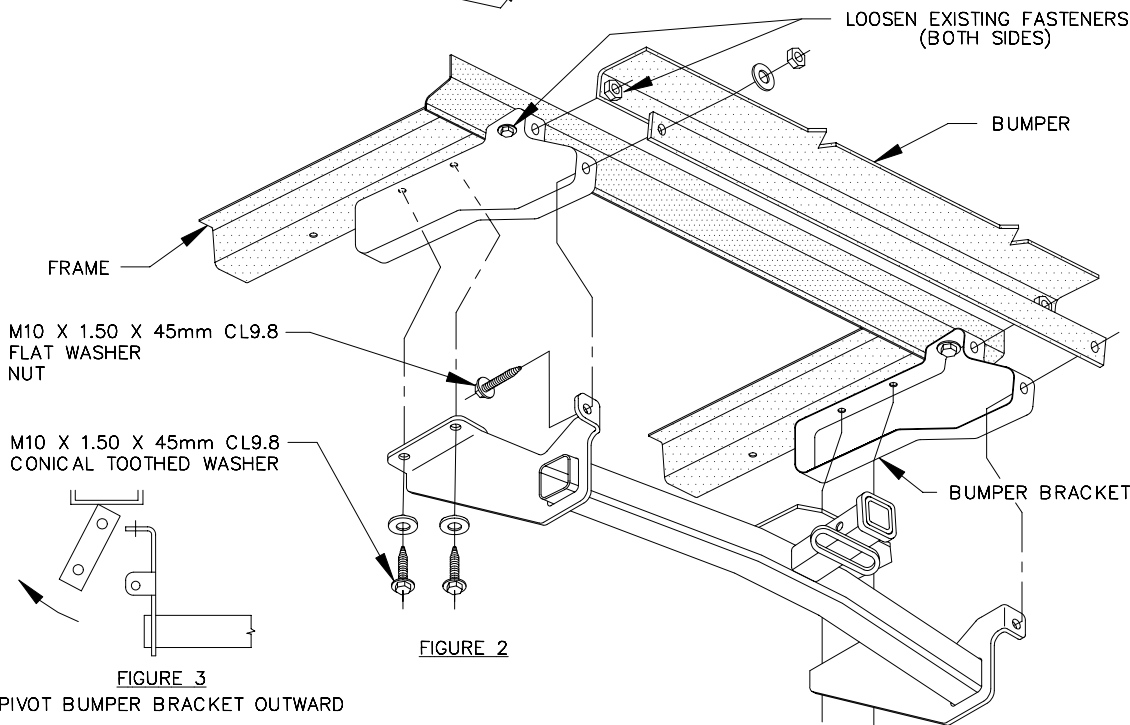

FIGURE 3
 PIVOT BUMPER BRACKET OUTWARD

WARNING:

ON STANDARD VANS, A FULL SIZE SPARE CANNOT BE STOWED UNDER VEHICLE WITH HITCH INSTALLED, BECAUSE CLEARANCE WITH BRAKE LINE AND PARKING BRAKE CABLE MOUNTED ON DIFFERENTIAL MAY NOT BE ADEQUATE. ON EXTENDED VANS A FULL SIZE SPARE CAN BE STOWED UNDER VEHICLE WITH HITCH INSTALLED. IF CLEARANCE WITH ANY SPARE TIRE IS NOT ADEQUATE, SPARE MUST BE STOWED ELSEWHERE ON VEHICLE, SEE FIGURE 1.

1. REMOVE (2) FORWARD BUMPER BRACKET TO FRAME BOLTS AND (1) BOTTOM BUMPER BRACKET TO BUMPER BOLT, ON EACH SIDE, SEE FIGURE 2. LOOSEN REMAINING BUMPER BRACKET BOLTS. RETURN BOLTS TO VEHICLE OWNER FOR REINSTALLATION IN THE EVENT THAT THE HITCH IS REMOVED FROM THE VEHICLE.

NOTE: BUMPER BRACKETS REMAIN IN PLACE WITH HITCH INSTALLED.

2. WHILE PIVOTING THE BUMPER BRACKETS OUTWARD, LIFT THE RECEIVER INTO POSITION, CENTERING THE SLOTS IN THE SIDE BRACKETS OVER THE WELDNUTS IN THE FRAME, SEE FIGURE 3.

3. INSTALL FASTENERS AS SHOWN IN FIGURE 2. A SOCKET AND LONG EXTENSION IS NECESSARY TO TIGHTEN THE LOWER BUMPER BOLTS, SEE FIGURE 1.

NOTE: (4) OF THE (6) M10 NUTS SUPPLIED ARE FOR SHIPPING PURPOSES ONLY.

TIGHTEN ALL M10 FASTENERS TO 42 LB.-FT.

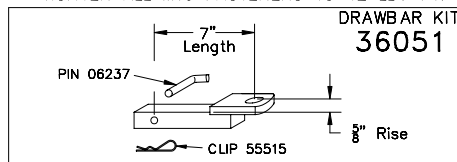

USE ONLY THE DRAWBAR SHOWN FOR CORRECT BUMPER CLEARANCE AND HEIGHT.

DRAWBAR MUST BE USED IN THE RISE POSITION ONLY.

THIS PRODUCT COMPLIES WITH SAFETY SPECIFICATIONS AND REQUIREMENTS FOR CONNECTING DEVICES AND TOWING SYSTEMS OF THE STATE OF NEW YORK, V.E.S.C. REGULATION V-5 AND SAE J684.

APPROX WEIGHT (LB.)	FASTENER KIT
28	01130-965

NOTE: Check hitch frequently, making sure all fasteners and ball are properly tightened. If hitch is removed, plug all holes in trunk pan or other body panels to prevent entry of water and exhaust fumes. A hitch or ball which has been damaged should be removed and replaced. Observe safety precautions when working beneath a vehicle and wear eye protection. Follow car maker's specs for maximum trailer weight and tongue weight. Do not cut access or attachment holes with a torch.

TOWING PRODUCTS
 Plymouth, Michigan