

INSTALLATION INSTRUCTIONS

EQUIPMENT REQUIRED:

WIRING ACCESS LOCATION:

DRILL BITS: NONE

HITCH REQUIRES 1/2" PIN & CLIP

WRENCHES: (TIGHTEN ALL FASTENERS WITH TORQUE WRENCH) 7/8

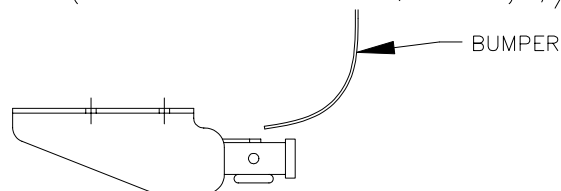

HITCH SHOWN IN PROPER POSITION

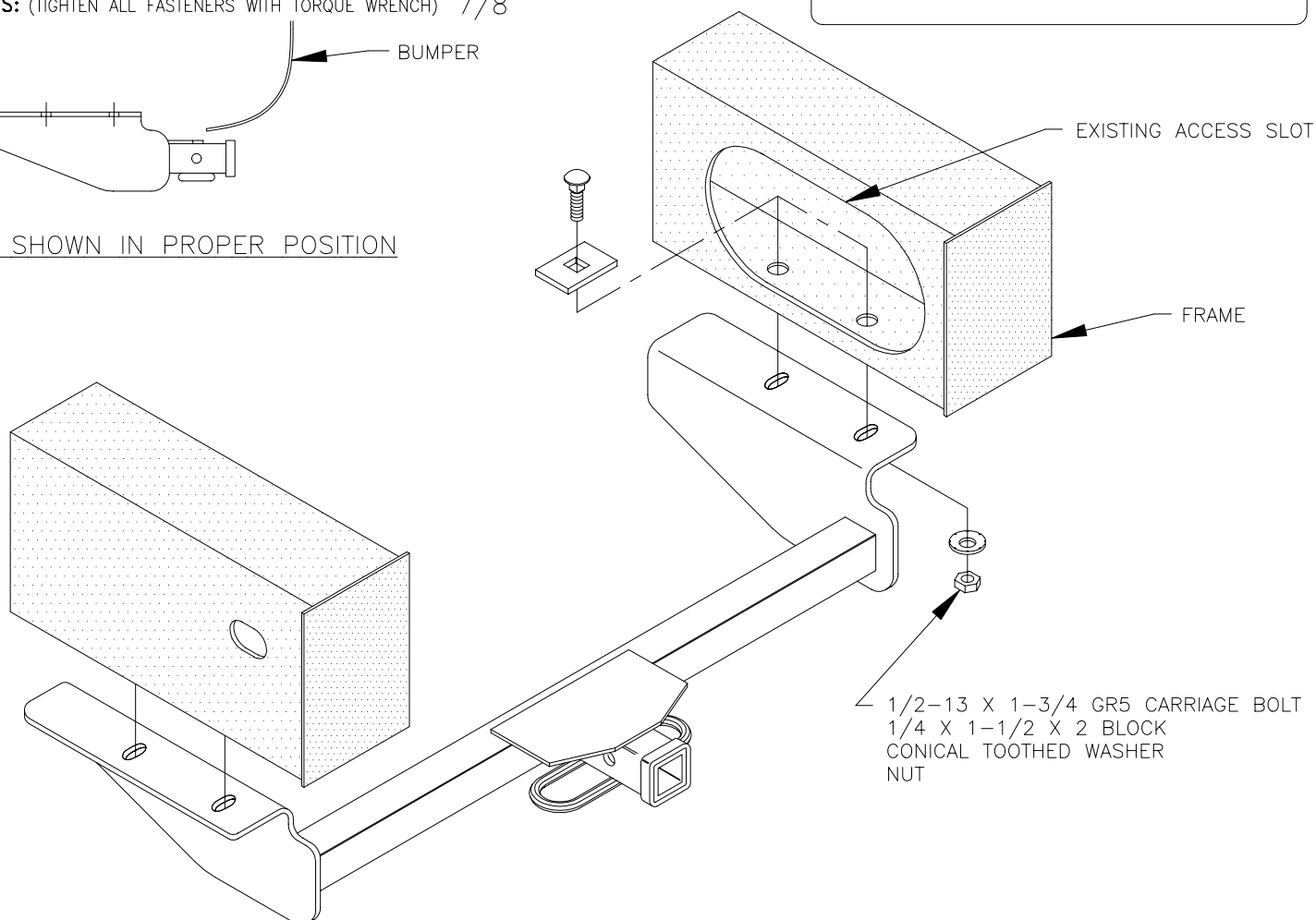

1. INSERT CARRIAGE BOLT AND BLOCK THROUGH EXISTING ACCESS SLOT AND INTO REAR ATTACHMENT HOLE AS SHOWN ABOVE, EACH SIDE.
2. RAISE HITCH INTO POSITION AND LOOSELY FASTEN WITH CONICAL TOOTHED WASHER AND NUT AS SHOWN ABOVE, EACH SIDE.
3. INSTALL REMAINING FASTENERS AS SHOWN ABOVE.

TIGHTEN 1/2 GR5 FASTENERS TO 75 LB.-FT.

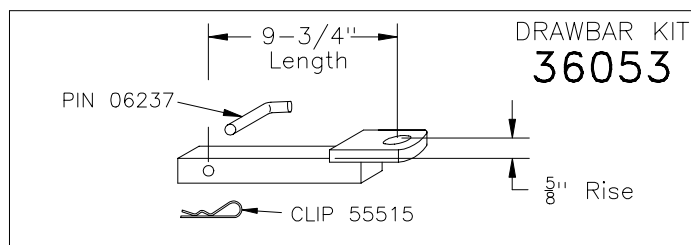

USE ONLY THE DRAWBAR SHOWN FOR CORRECT BUMPER CLEARANCE AND HEIGHT.
DRAWBAR MUST BE USED IN THE RISE POSITION ONLY.

THIS PRODUCT COMPLIES WITH SAFETY SPECIFICATIONS AND REQUIREMENTS FOR CONNECTING DEVICES AND TOWING SYSTEMS OF THE STATE OF NEW YORK, V.E.S.C. REGULATION V-5 AND SAE J684.

APPROX WEIGHT (LB.)

25

FASTENER KIT

01130-932

NOTE: Check hitch frequently, making sure all fasteners and ball are properly tightened. If hitch is removed, plug all holes in trunk pan or other body panels to prevent entry of water and exhaust fumes. A hitch or ball which has been damaged should be removed and replaced. Observe safety precautions when working beneath a vehicle and wear eye protection. Follow car maker's specs for maximum trailer weight and tongue weight. Do not cut access or attachment holes with a torch.

TOWING PRODUCTS
Plymouth, Michigan