

INSTALLATION INSTRUCTIONS

VEHICLE	HITCH NO.
TOYOTA AVALON	36293 06025 90198

EQUIPMENT REQUIRED:
 WIRING ACCESS LOCATION: PC3, PC4
 DRILL BITS: 1/2
 HITCH REQUIRES 1/2" PIN AND CLIP
 WRENCHES: (TIGHTEN ALL FASTENERS WITH TORQUE WRENCH) 11/16, 14mm, 17mm

3500 LB MAX GROSS TRAILER WT
 300 LB MAX TONGUE WEIGHT
 DO NOT EXCEED TOWING VEHICLE RATINGS

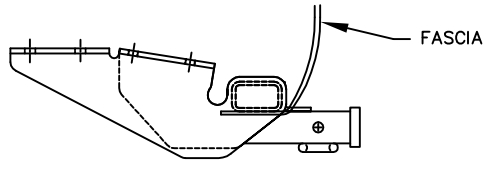

HITCH SHOWN IN PROPER POSITION

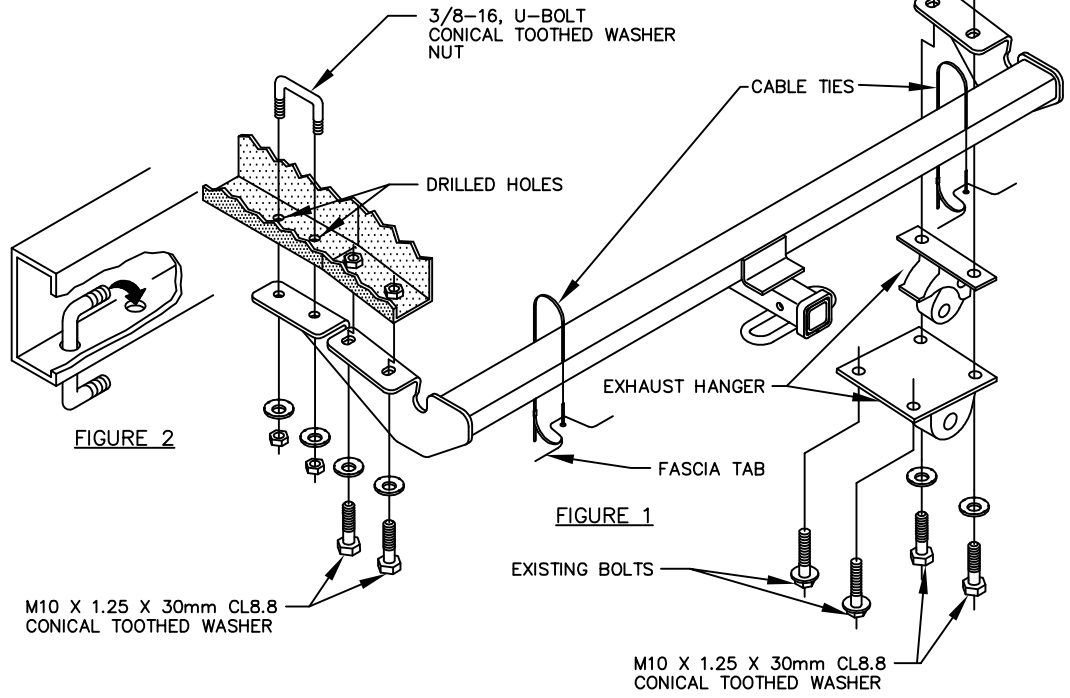

- IF PRESENT, REMOVE TIE DOWN BRACKETS AND BOLTS FROM EACH SIDE OF VEHICLE FRAME. RETURN TO VEHICLE OWNER. REMOVE (2) OR (4) 10mm BOLTS HOLDING EXHAUST HANGER TO VEHICLE.
- REMOVE FASCIA FASTENERS AND RAISE HITCH INTO POSITION ABOVE FASCIA. INSTALL (4) 10mm BOLTS AND CONICAL TOOTHED WASHERS AS SHOWN IN FIGURE 1.
 - SIDE BRACKET IS TO BE SANDWICHED BETWEEN EXHAUST HANGER AND FRAME.
 - FOR (2) BOLT EXHAUST HANGER CONFIGURATION, INSTALL (2) 10mm BOLTS AND CONICAL TOOTHED WASHERS SUPPLIED WITH HITCH AS SHOWN IN FIGURE 1.
 - FOR (4) BOLT EXHAUST HANGER CONFIGURATION, INSTALL (2) 10mm EXISTING BOLTS (RETAINED IN STEP 1) AND (2) 10mm BOLTS AND CONICAL TOOTHED WASHERS SUPPLIED WITH HITCH AS SHOWN IN FIGURE 1.
- USING HITCH AS TEMPLATE DRILL (2) 1/2" HOLES IN VEHICLE FRAME AS SHOWN IN FIGURE 1.
- INSERT U-BOLT AS SHOWN IN FIGURE 2. INSTALL CONICAL TOOTHED WASHERS AND 3/8 HEX NUTS.

NOTE: ON TWIN TIP EXHAUST MODELS, EXHAUST CLEARANCE CAN BE INCREASED BY LOOSENING (2) SET SCREWS ON EACH CHROME EXHAUST TIP AND REMOVING CHROME TIP. RETURN TIPS TO CUSTOMER FOR REINSTALLATION UPON REMOVAL OF HITCH.
- USE CABLE TIES TO SECURE FASCIA TO THE CROSS TUBE.

TIGHTEN ALL M10 CL8.8 TO 38 LB-FT.
 TIGHTEN ALL 3/8 U-BOLT NUTS TO 25 LB-FT.

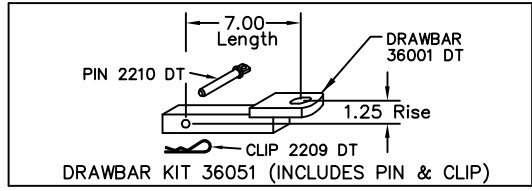

USE ONLY THE DRAWBAR SHOWN FOR CORRECT BUMPER CLEARANCE AND HEIGHT.
 DRAWBAR MUST BE USED IN THE RISE POSITION ONLY.

THIS PRODUCT COMPLIES WITH SAFETY SPECIFICATIONS AND REQUIREMENTS FOR CONNECTING DEVICES AND TOWING SYSTEMS OF THE STATE OF NEW YORK AND V.E.S.C. REGULATION V-5.

APPROX WEIGHT (LB.)	FASTENER KIT NO.
29	F36293

NOTE: Check hitch frequently, making sure all fasteners and ball are properly tightened. If hitch is removed, plug all holes in trunk pan or other body panels to prevent entry of water and exhaust fumes. A hitch or ball which has been damaged should be removed and replaced. Observe safety precautions when working beneath a vehicle and wear eye protection. Follow car maker's specs for maximum trailer weight and tongue weight. Do not cut access or attachment holes with a torch.

