

# **MXB-250 250,000 BTU BOILER**

**&**

# **MXB-400 400,000 BTU BOILER**

## **Installation and Operating Instructions**



**Lanair Products LLC**  
4109 Capital Circle  
Janesville, Wisconsin 53546  
1-888-370-6531  
[www.lanair.com](http://www.lanair.com)





## **BEFORE YOU BEGIN INSTALLATION...**

***Read and understand this manual completely before beginning installation.***

### **Code Requirements**

Installation must comply with all state, local and utility codes, laws, regulations and ordinances and CSA standard B139. When required, installations must conform to A.S.M.E. safety code for controls and safety devices for automatically fired boilers No. CSD-1.

All electrical wiring must be done by a licensed electrician in accordance with the National Electrical codes latest edition and all state and local codes.

### **Rules for Safe Installation and Operation**

1. This boiler is for commercial and industrial use only. **This unit is not intended for residential use.**
2. This boiler must be installed by a licensed HVAC/Hydronic contractor. Installer should be trained and thoroughly familiar with the installation and operation of oil-fired boilers.
3. Read this owner's manual and the rules for safe operation carefully. Failure to follow the rules of safe operation and the instructions could cause a malfunction of the boiler and result in death, serious bodily injury, and/or property damage.
4. Locate the boiler as close to the chimney as practical. Observe the minimum clearances outlined in Fig. 1, page 8. Remember to allow room for the boiler door to open with the burner mounted.
5. Make sure that the surface on which the boiler is to be installed is capable of supporting the weight of the boiler, burner, and all other equipment supported by that surface.
6. A boiler pad is strongly recommended. This pad is to be made of poured concrete. It should be at least 4 inches thick and should cover the entire area underneath the boiler (not just the legs).
7. Make sure the location chosen for the boiler will provide adequate air for combustion and ventilation (see Fig. 2, page 9). Also make sure that fuel and electrical requirements can be satisfied at the boiler location chosen.
8. The heating system design shall not permit the boiler's return water temperature to be lower than 130°F for a significant period of time. This will prevent fire side corrosion and insure a long life expectancy for your boiler.
9. Check to make sure you have all the required components needed for proper installation and operation.
10. Check each component for visible damage. If you find a damaged component, contact a Lanair Service Representative for a replacement. Do not install broken or damaged parts.
11. This boiler is designed to provide economically and environmentally friendly disposal of waste oil. Due to the nature of the fuel used, this boiler should not be relied upon as the sole source of heat.
12. Read and understand the warranty. Fill out the enclosed warranty card and return within 10 days of purchase.

# MXB 250/400 250,000/400,000 BTU BOILER Installation and Operating Instructions

## Table of Contents:

	Code Requirements and Rules For Safe Installation and Operation .....	page 2
<b>Sec. 1</b>	General Specifications .....	page 4
<b>Sec. 2</b>	Typical Boiler Room Layout .....	page 8
<b>Sec. 3</b>	Boiler Room Air Requirements .....	page 8
<b>Sec. 4</b>	Chimney/Vent System .....	page 10
<b>Sec. 5</b>	Draft .....	page 11
<b>Sec. 6</b>	Fuel Supply Tank Piping Installation .....	page 12
<b>Sec. 7</b>	Fuel Supply Pump/Piping .....	page 13
<b>Sec. 8</b>	Typical Boiler Piping .....	page 15
<b>Sec. 9</b>	Boiler Installation .....	page 16
<b>Sec. 10</b>	Boiler Controls and Accessory Location .....	page 20
<b>Sec. 11</b>	Burner Installation .....	page 21
<b>Sec. 12</b>	Electrical Connections/Wiring Diagram .....	page 22
<b>Sec. 13</b>	Compressed Air Installation .....	page 24
<b>Sec. 14</b>	Controls .....	page 25
<b>Sec. 15</b>	Start Up Procedure .....	page 26
<b>Sec. 16</b>	Priming Fuel Pump .....	page 28
<b>Sec. 17</b>	Flame Adjustment .....	page 29
<b>Sec. 18</b>	Maintenance Schedule / Service Adjustments .....	page 31
<b>Sec. 19</b>	Troubleshooting .....	page 40
<b>Sec. 20</b>	Warranty Certificate .....	page 42
<b>Sec. 21</b>	Burner Reference Diagram .....	page 43



## Section 1 - Burner Specifications

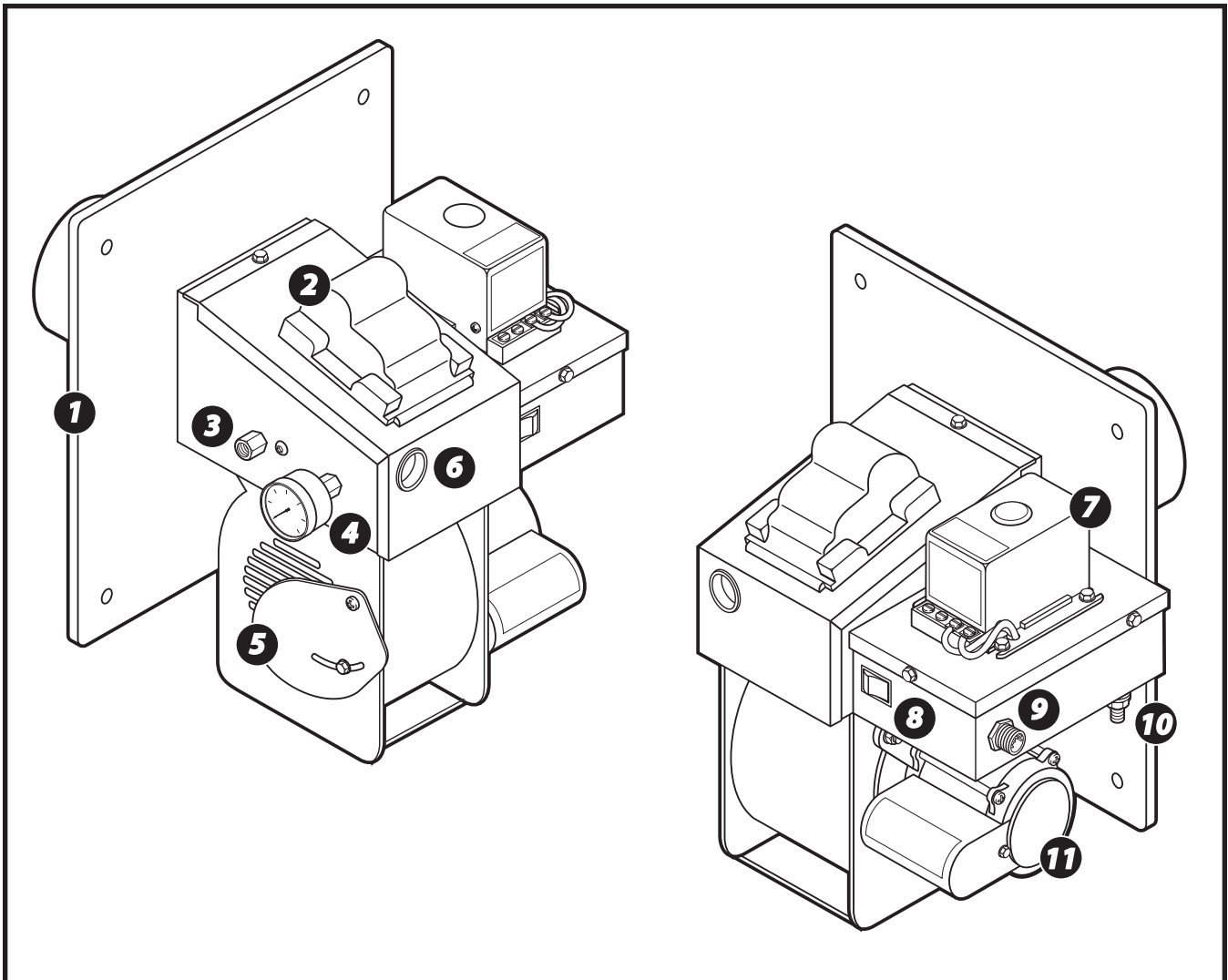

No.	Description
1	Mounting Plate
2	Ignitor Transformer
3	Fuel Line Inlet
4	Fuel Pressure Gauge
5	Combustion Air Baffle
6	View Port
7	Oil Primary Safety Control
8	Waste Oil/Fuel Oil Switch
9	Quick Disconnect Receptacle
10	Air Supply Inlet
11	Combustion Blower Motor

### Burner Assembly-Performance Ratings

Voltage	..... 115 vac
Cycles	..... 60 hz
Total Operating Amperage	..... 4.9
Weight	.....31 lbs
Oil Primary	..... 0.2 amps
Pre-Heater Block	.....2.6 amps
Ignitor Transformer	..... 0.3 amps

## Section 1 - Pump Specifications

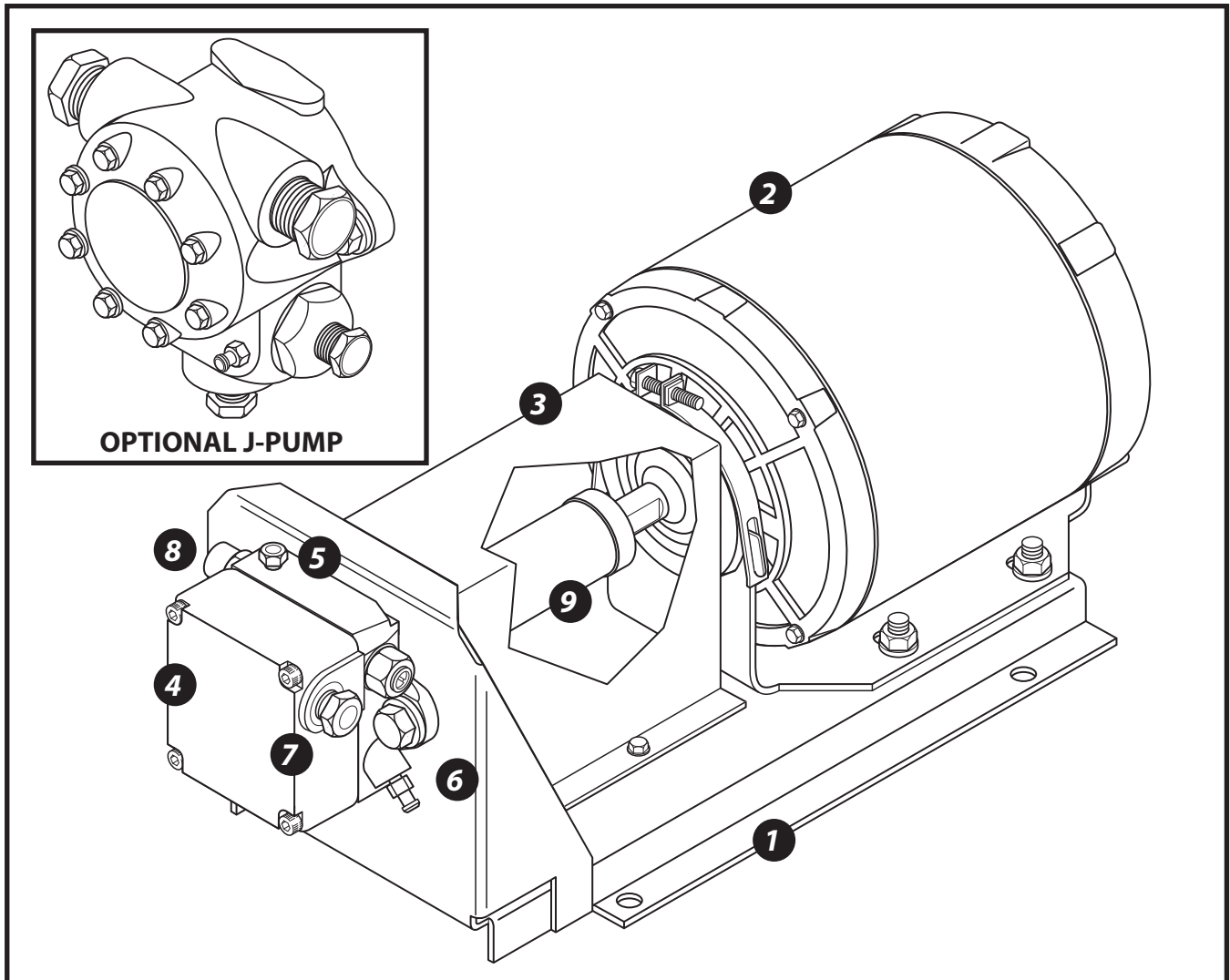

No.	Description
1	Pump Platform
2	Pump Motor
3	Adapter Shaft Cover
4	Pump
5	Pressure Gauge port
6	Easy Flow Bleed Valve
7	1/4" NPT Inlet
8	1/8" NPT Outlet
9	Adapter Shaft

### Pump Assembly-Performance Ratings

Voltage ..... 115 vac  
 Cycles ..... 60 hz  
 Weight ..... 24 lbs  
 Pump Motor ..... 5 amps



## Section 1 - Boiler Specifications

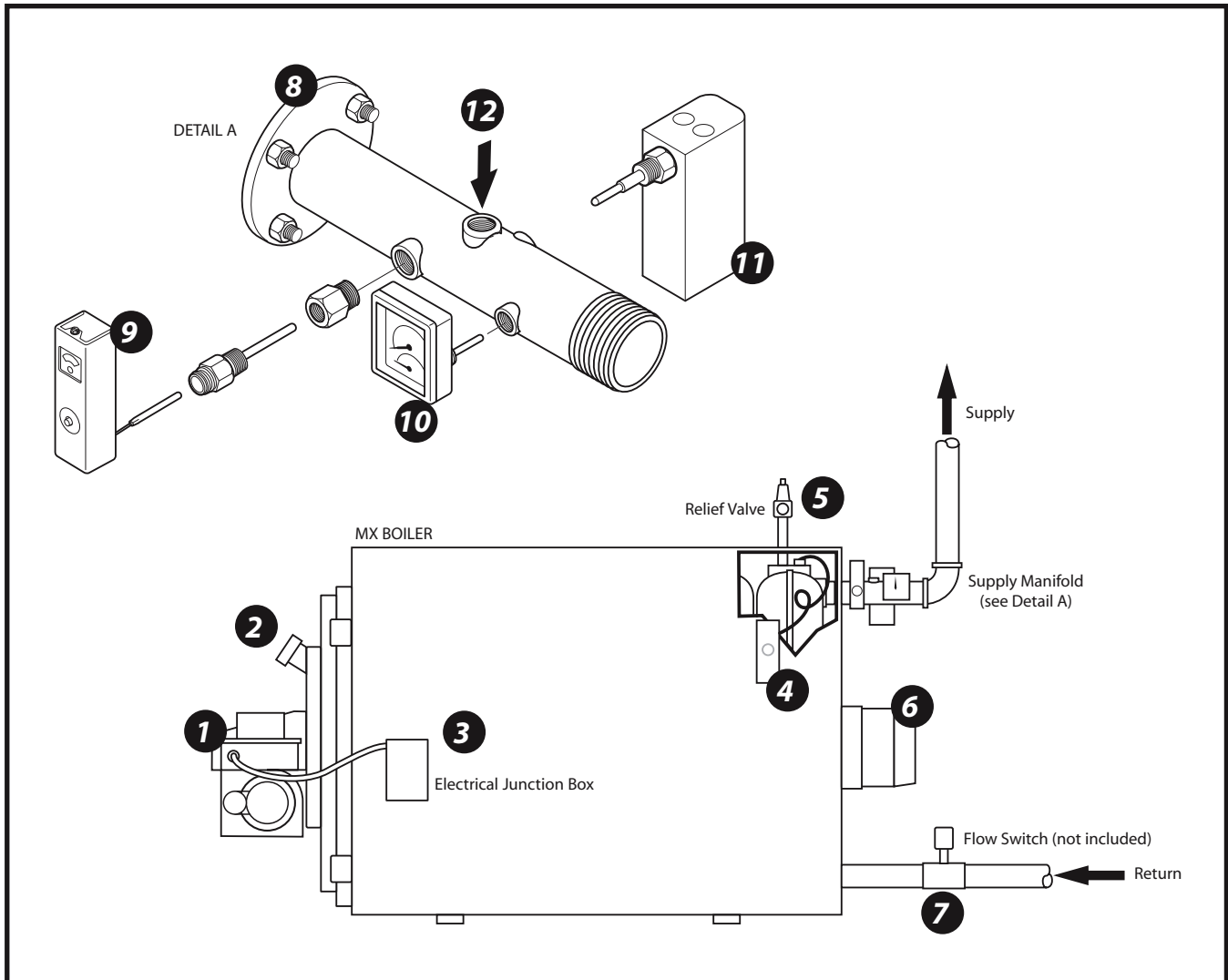

No.	Description
1	Burner Assembly
2	View Port
3	Electrical Junction Box
4	HI-Limit Switch
5	Relief Valve
6	Chimney Outlet
7	Flow Switch (not included)
8	Supply Manifold
9	Hi-Limit Switch
10	Temperature/Pressure Gauge
11	Low Water Cut-off Switch
12	Optional Relief Valve Location

### Boiler-Performance Ratings

**400/250**

Burner Fuel Consumption	..... 2.86/1.79 GPH
Input	..... 400,000 / 250,000 BTU
Output Capacity	..... 338,000/211,250 BTU
Net Rating - Water BTU/HR	.. 364,000/227,500 BTU
Approx. Dry Weight	..... 1,900/1,600 lbs.
Vent Connect	..... 8" dia.
Water Content	..... 28.5/22.2 gal.
Max Operating Water Pressure	..... 75 PSI

## Section 1 - Boiler Specifications

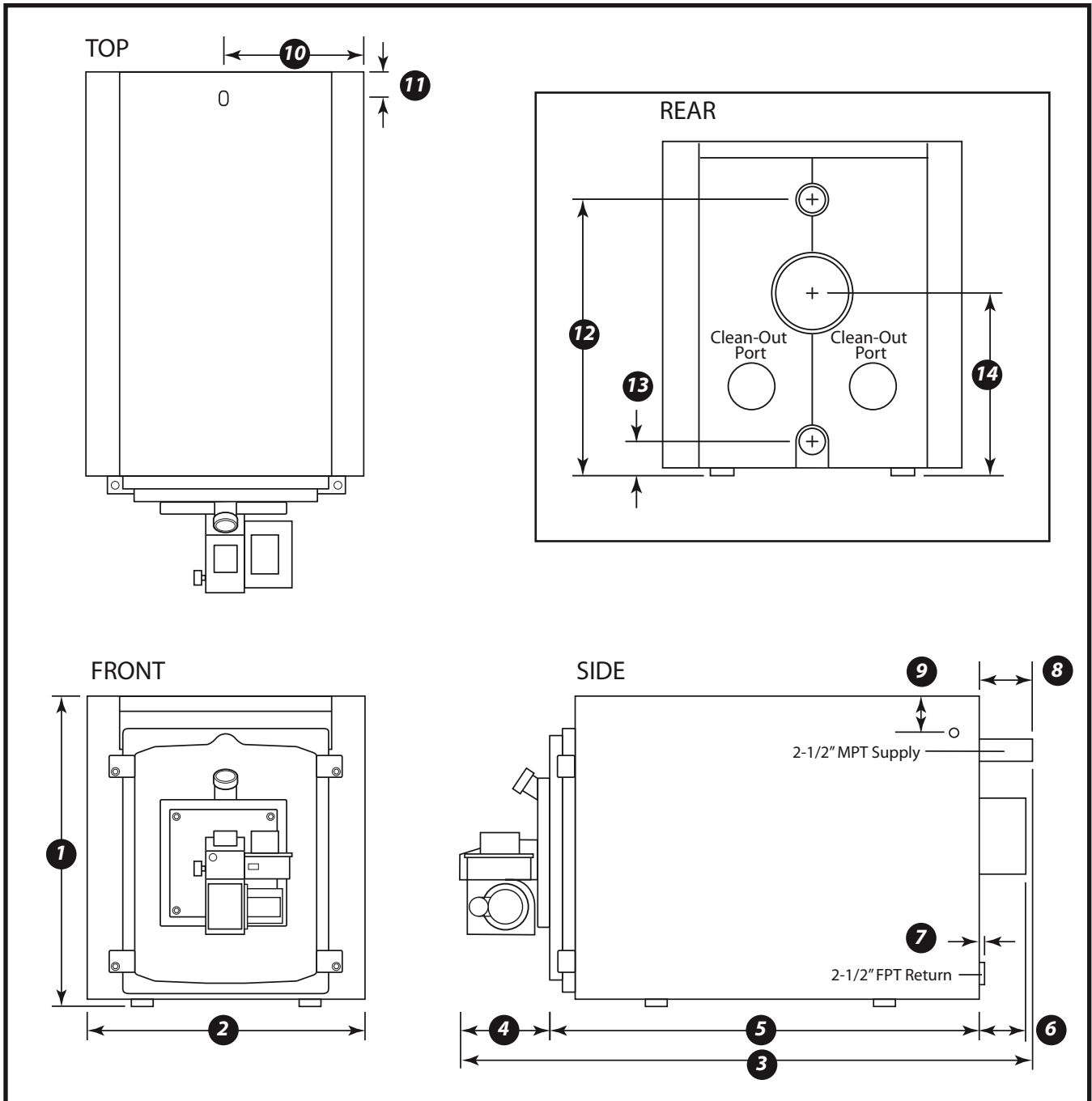

No.	Dimension		No.	Dimension	No.	Dimension
	400	250				
1	36"	36"	7	3/4"	13	4" oc
2	33"	33"	8	9-3/8"	14	20" oc
3	73-3/8"	63-3/8"	9	7-3/4" oc		
4	12"	12"	10	18" oc		
5	52"	42"	11	5" oc		
6	8"	8"	12	29-1/2" oc		

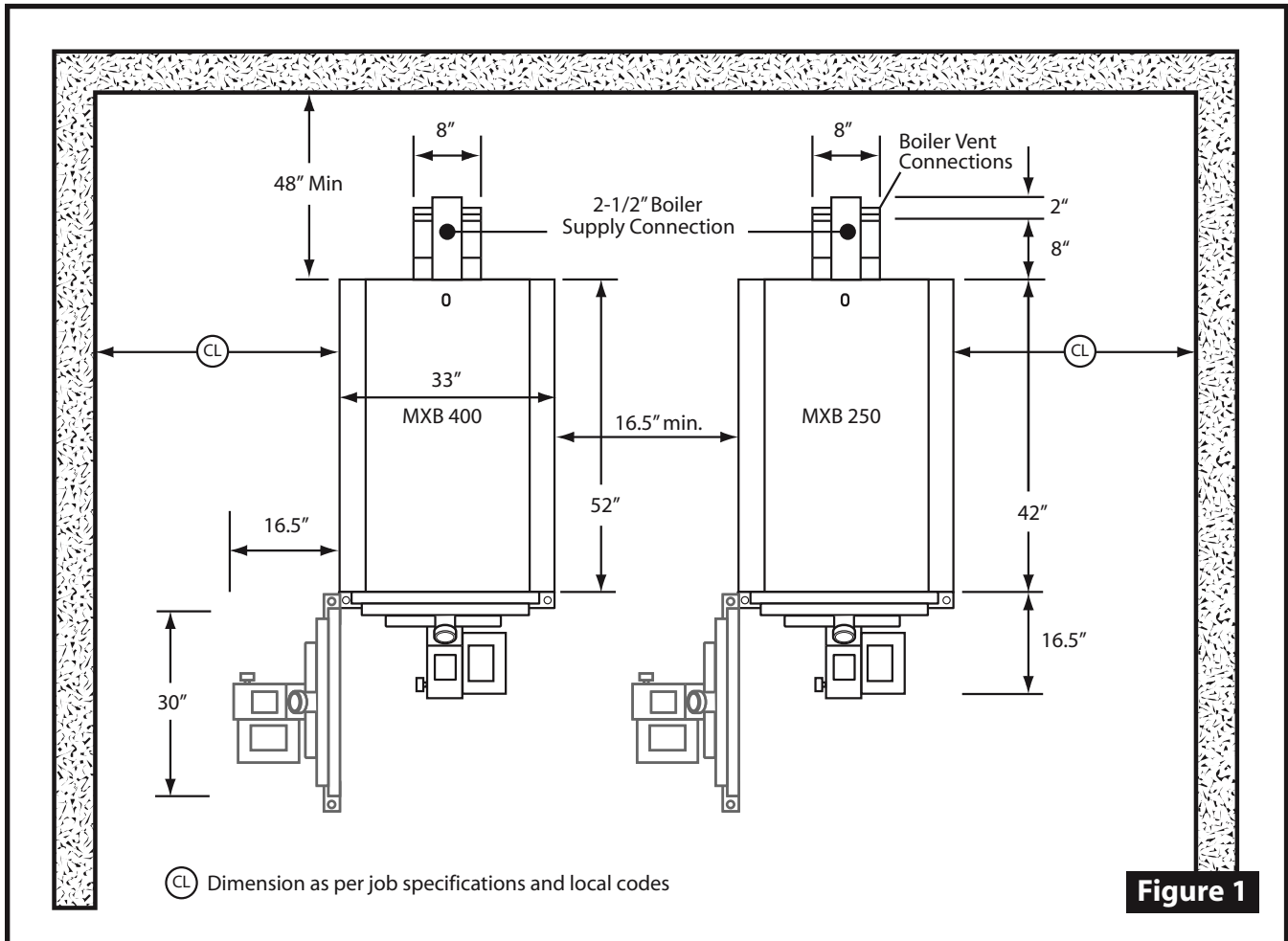

**Figure 1**

## Section 3 - Boiler Room Air Requirements

**! WARNING: Failure to provide an adequate supply of fresh air for combustion will result in hazardous operating conditions. Do not use an exhaust fan in the boiler room.**

1. To ensure safe efficient operation, the boiler system must be supplied with sufficient air for combustion and ventilation (see Fig. 2)
2. Unless properly controlled, avoid the use of forced ventilation, since it can create an undesirable pressure differential between the boiler room and air source.
3. All boilers located in confined rooms should have free access to ventilation and combustion air from two permanent openings. One opening should terminate within 12" of the ceiling, the other within 12" from the floor (see Fig. 2). Each opening shall have at least 1 sq. inch free area per 1,000 BTU/HR of burner input. Openings should freely connect with areas having adequate infiltration of outside air



## Section 3 - Boiler Room Air Requirements

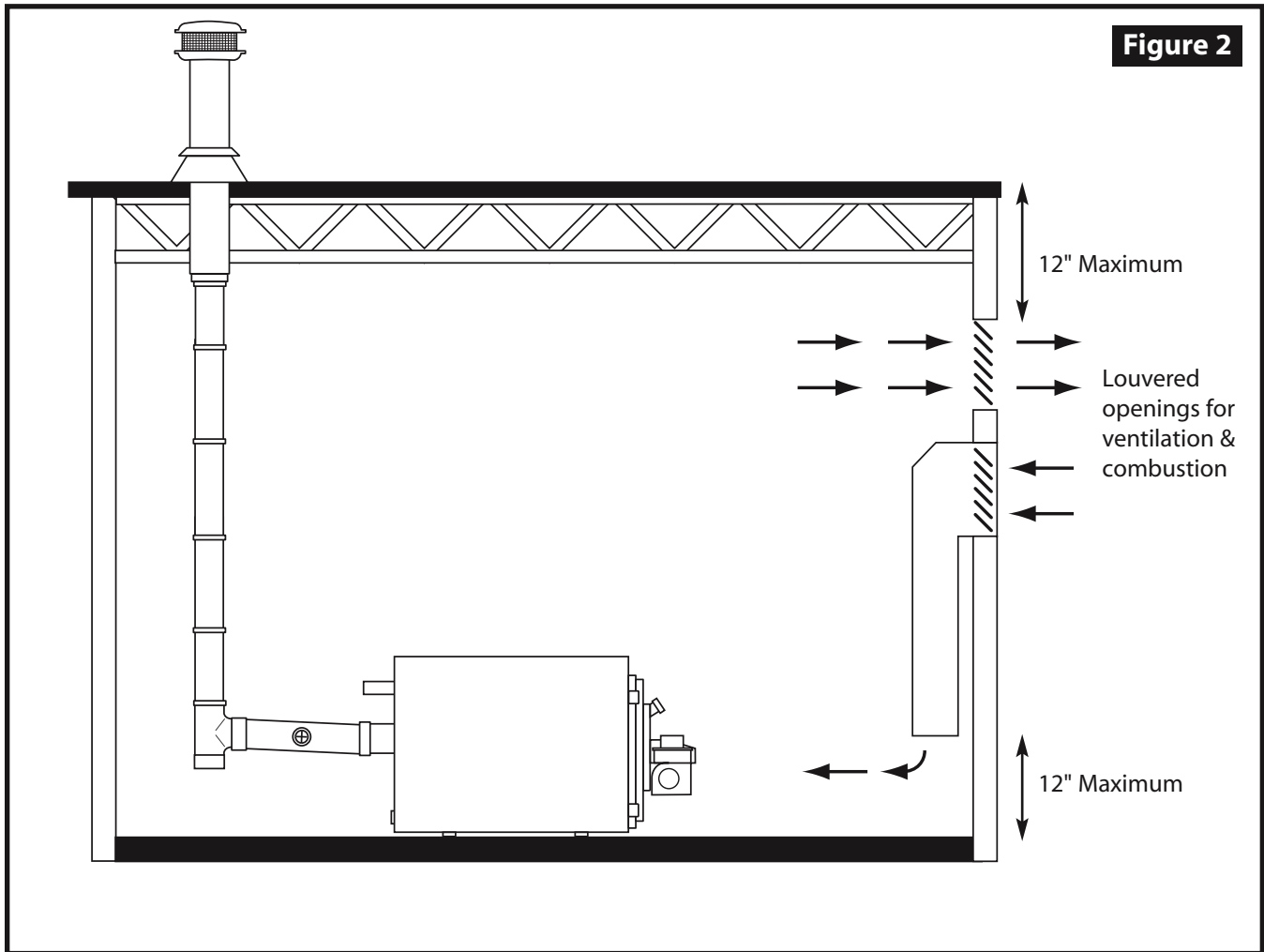

When air comes directly from outdoors, again use two openings as explained on page 8 and above except:

- All ducting shall be the same size as opening but no less than 3" x 3" or 9 square inches.

Remember to compensate for louver blockage when calculating free air. Refer to manufacturer's instructions or use this general guide:

**WOOD LOUVERS**- Allow 20-25% free air

**METAL LOUVERS OR GRILLES** - Allow 60-70% free air

Any louver damper should lock open or open automatically when the boiler operates.



## Section 4 - Chimney or Vent System

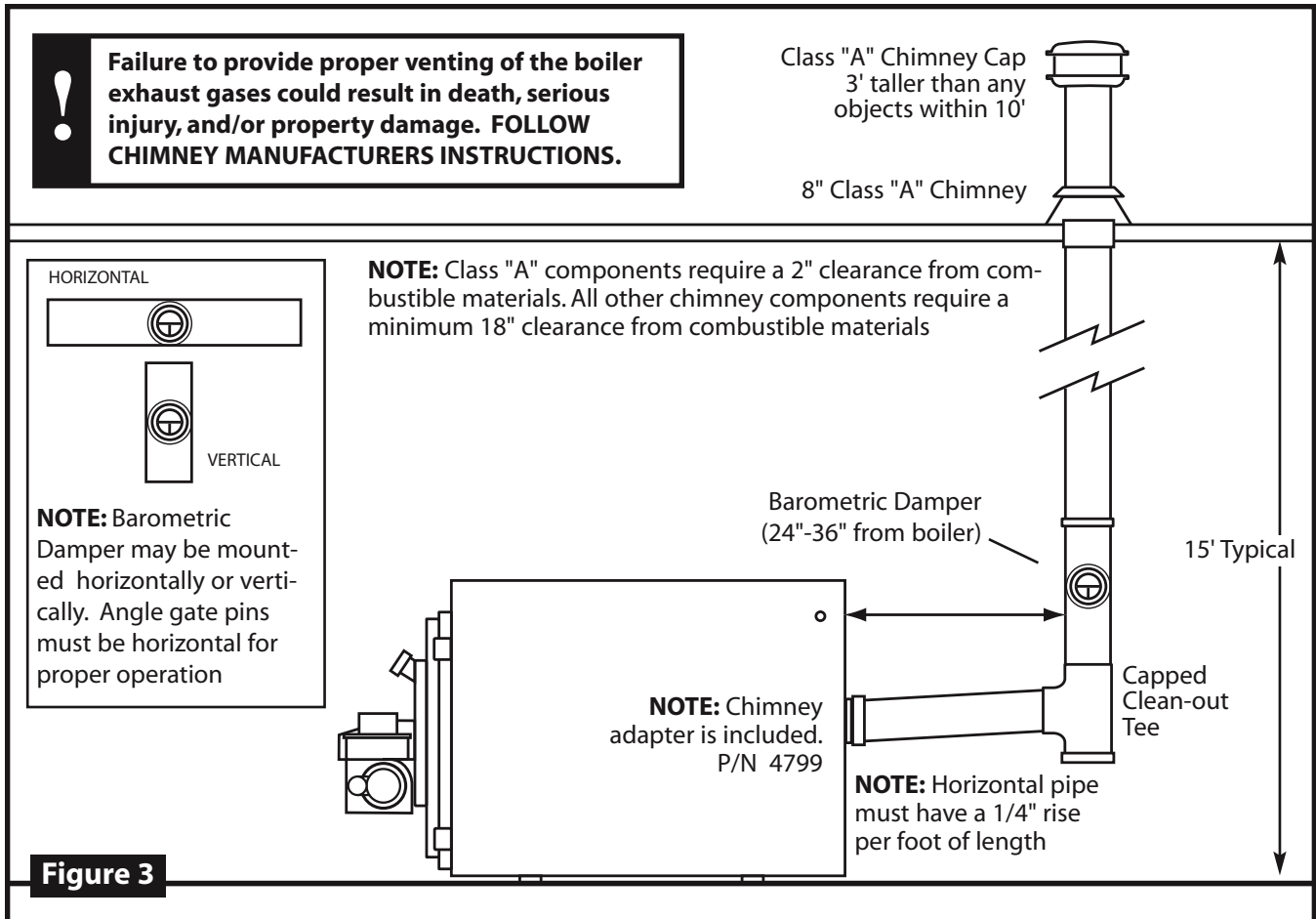

**Figure 3**

### General Requirements

1. Chimney **MUST** be a 8" Class "A" chimney. **Do Not Use chimney smaller than 8"**
2. **INSTALLATION MUST BE DONE BY A LICENSED HVAC/HYDRONIC CONTRACTOR FAMILIAR WITH ALL STATE AND LOCAL CODES.** Safe operation of any gravity vented heating appliance requires a proper air make-up system to prevent the heater exhaust gases from being drawn into the building. These gases could cause death, serious injury, and/or property damage. Exhaust fans, paint booths may cause draft problems.
3. Never vent this boiler into another heating appliances chimney. **Never vent into 'Class B' chimney. Gas boilers use "Class B" chimney, it is rated for a much lower temperature than is required for your waste oil boiler. This boiler must have its own separate "Class A" chimney.**
4. Inspect and maintain the chimney on an annual basis.
5. Install a U.L. listed barometric damper in the chimney. Do not reduce or enlarge the vent pipe.
6. Position the draft control as shown. Chimney angle gate pins must be horizontal for proper operation.
7. Keep the barometric draft control at least 24" from the boiler.

## Section 4 - Chimney or Vent System

8. Do not use more than one 90° elbow. Each 90° elbow equals a 10' run of chimney. The maximum run for the chimney connector is 30'.
9. Secure all connections in the chimney connector with 3 screws per joint.
10. The chimney connector clearance to any combustible material is 18". The Class "A" chimney clearance to any combustible is 2". **FOLLOW THE CHIMNEY MANUFACTURER'S INSTRUCTIONS.**
11. Do not install heat re-claimers, manual draft controls, or any other type of restrictive control in the chimney.
12. Install a 8" diameter clean out tee with a cap, at the transition of the chimney.  
**FOLLOW CHIMNEY MANUFACTURER'S INSTRUCTIONS.**
13. Use a 8" inside diameter "Class A" insulated chimney pipe to vent exhaust gases through wall, ceilings, attics, roofs, combustibles, etc..
14. Vent chimney at least 3 feet above the roof and at least 3 feet higher than any portion of the building, roof, or obstruction within 10 feet of the chimney.
15. The chimney cap should be at least 3' above the roof exit.
16. Do not use a rotating chimney cap. Use a non-restrictive "Class A" cap made for the type of "Class A" chimney you are using. **FOLLOW CHIMNEY MANUFACTURER'S INSTRUCTIONS.**
17. The chimney must be capable of producing a negative -.02 W.C. draft when cold and -.06 W.C. draft when hot. Refer to Section 5 Draft Instructions.
18. If you are unable to attain the proper draft, check for exhaust fans in the building. To test if there is a problem, open an overhead door and see if you now have the proper draft. You may have to add one or more sections of "Class A" chimney to the roof to get the proper draft.
19. **The boiler and chimney must be installed in accordance with all state and local codes. The boiler must be installed by a licensed HVAC/Hydronics contractor in accordance with the specifications listed in this manual. The chimney must be installed per the chimney manufacturers instruction. Use "Class A" chimney only.**



**WARNING: FOLLOW THE CHIMNEY MANUFACTURER'S INSTALLATION INSTRUCTIONS AS WELL AS STATE AND LOCAL FIRE CODES.**

## Section 5 - Draft

The boiler should have a (negative) -.02 draft reading when cold, and a (negative) -.06 when hot. Check the boiler when it is running after 45 minutes. If the reading is not what it should be, adjust the barometric damper according to the instructions provided with the damper. The draft reading should be taken with a manometer. Consult your heating contractor, or manometers can be purchased from the Lanair Customer Service Department 1-888-370-6531.



## Section 6 - Fuel Supply Tank Installation

**Figure 4**

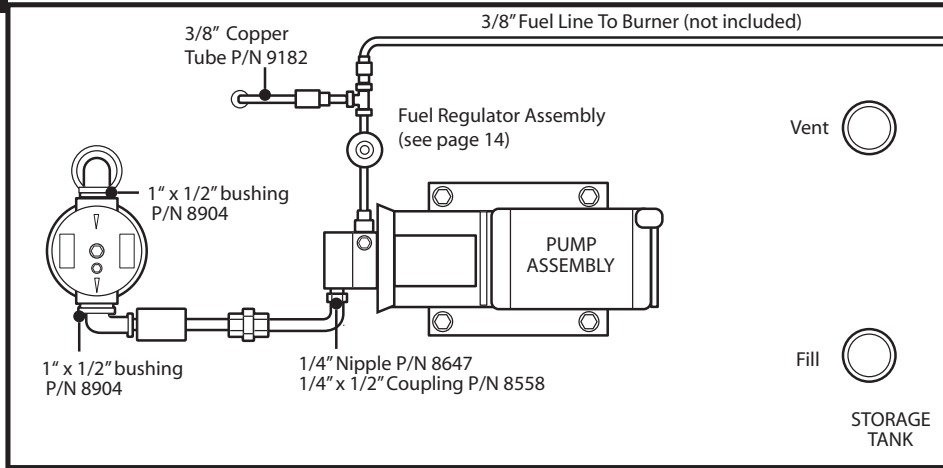

**TOP VIEW**

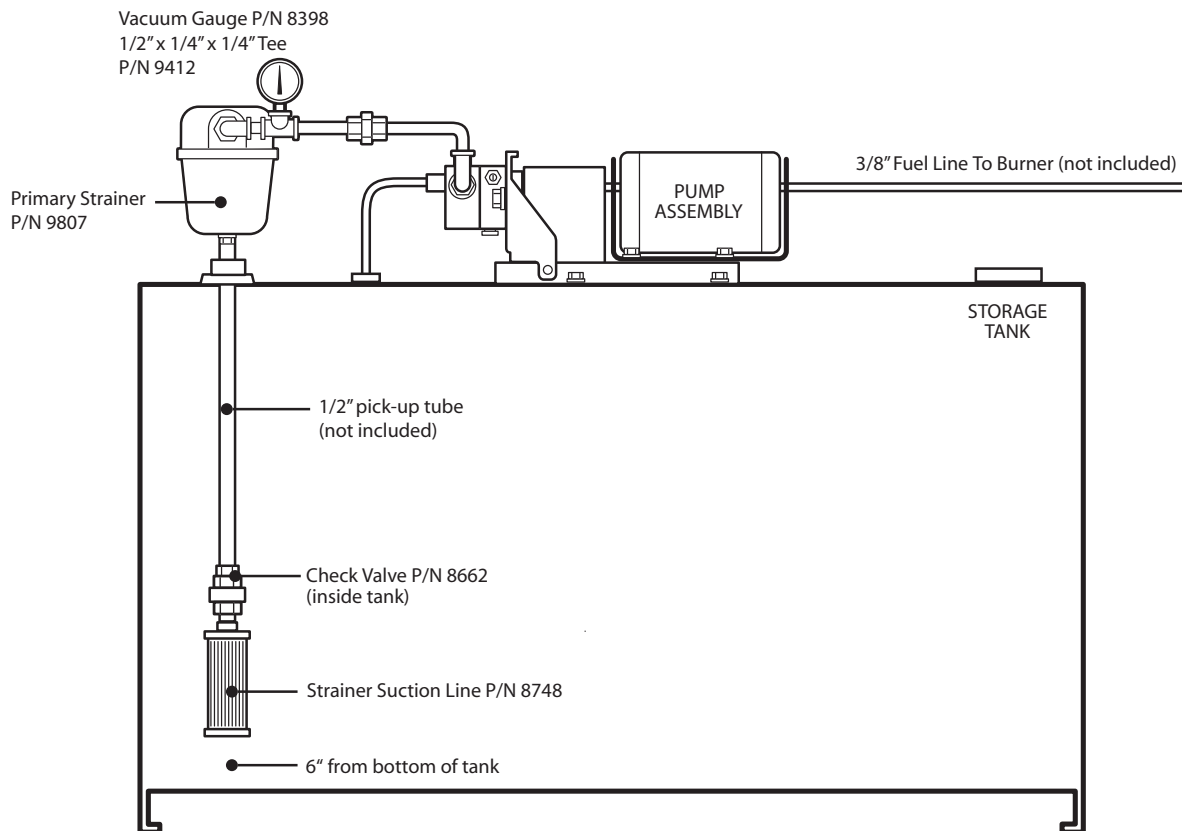

## Section 7 - Fuel Supply Pump/ Piping

### General Requirements - Fuel Tank

1. The fuel supply tank and supply lines must be installed in accordance with the National Fire Protection Association requirements, as well as state and local ordinances.
2. Regulations require oil storage tanks located inside a building not exceed 275 gallons individually and are not to exceed 550 gallons in one building. Check state and local codes.
3. Oil storage tank must be inside the building as close to the boiler as possible (max. 25 feet) to avoid flow problems.
4. Pitch the fuel supply 2° with the drain valve at the lowest end to drain off water and sludge. Sludge may have to manually be removed.
5. Some ordinances may require the fuel supply tank to be vented to outside, and above the roofline. Check State and Local codes. Keep the vent clear.
6. Install the fuel tank fill pipe at the end of the tank and above the drain.
7. Label the fuel tank for the recommended fuels.
8. Strain all fuel with a 50 X 50 mesh strainer before putting fuel into the tank.
9. When filling the fuel tank with a motorized pump, never leave unattended to prevent over filling and/or spillage.
10. Keep fill cap on the fuel tank when not filling.

### General Requirements - Fuel Pump/Piping

1. Mount the fuel supply pump in a horizontal position (shaft horizontal) near the fuel supply tank.
2. The oil pump has a maximum suction lift of 14 feet. Suction lift is the length of pipe run from the bottom of the pick up strainer to the fuel supply pump.
3. The fuel pump/motor are for indoor use only.
4. The fuel pump contains an internal strainer that periodically needs to be cleaned (see Section 18, page 33). This internal strainer is mounted behind the pump cover. Before removing the pump cover make sure you have a new gasket on hand. Contact the Lanair Customer Service Department for the proper gasket for your model of pump, at 1-888-370-6531.
5. Install the suction supply line from the inlet side of the fuel pump into the fuel tank opposite the drain.
6. Install a 1/2" inside diameter (.493) steel pipe, or 1/2" outside diameter copper throughout the suction supply line and pick up tube. The use of smaller line, or rubber, plastic or hydraulic line is unsafe and will void your warranty.
7. Use thread sealing compound on all pipe thread connections. **DO NOT USE TEFLON TAPE.**
8. Install the suction line strainer in the suction line. Make sure the suction line strainer is 6" off the bottom of the tank. The suction line strainer may be mounted horizontally or vertically. Consider accessibility.
9. Install a pipe union between the suction line strainer and the pick up tube to allow for service on the pick up tube.

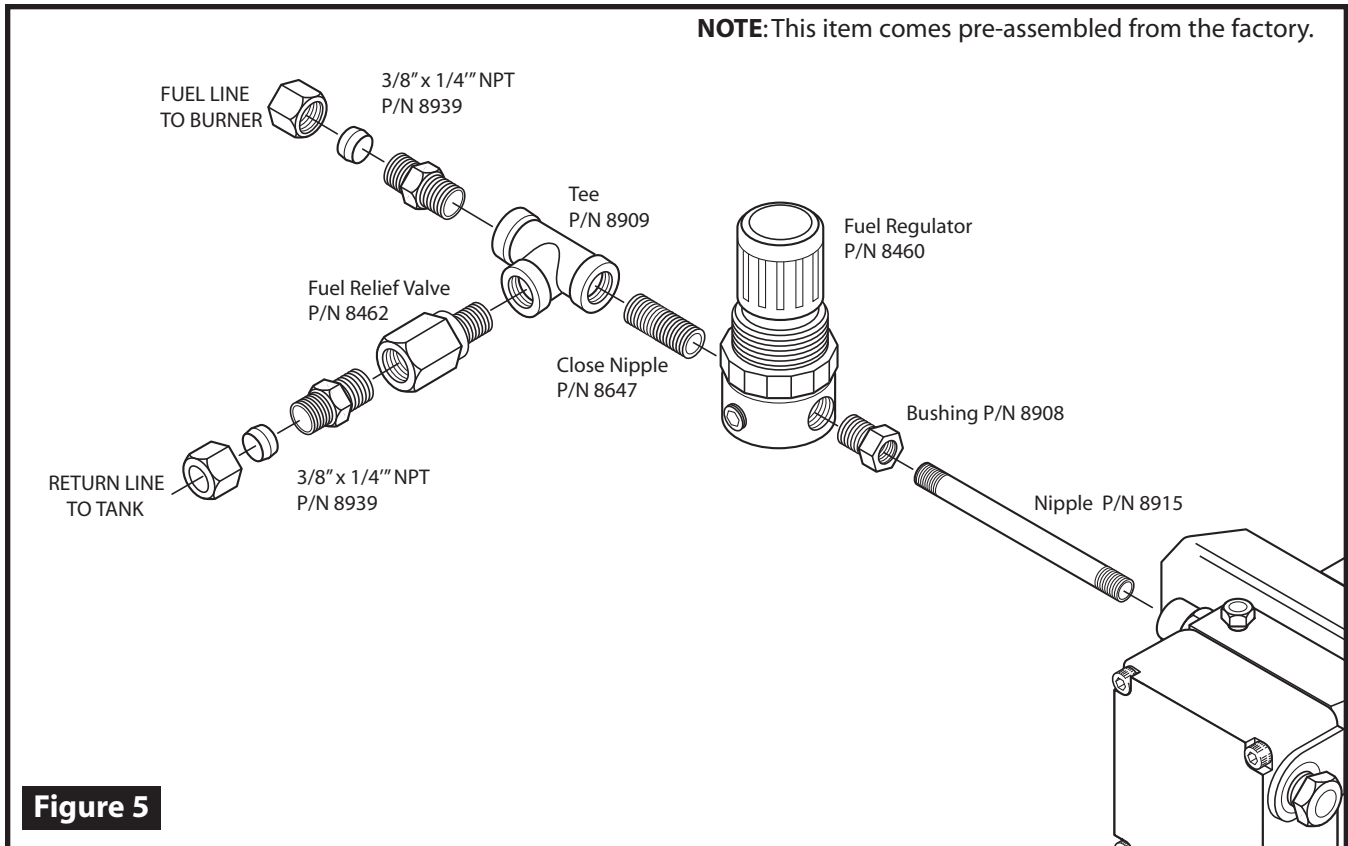

10. Install the check valve (arrow facing towards the pump) on the bottom of the pick up tube.
11. Install a vacuum gauge (included, P/N 8398) in the suction line. This gauge will indicate when service is needed on the strainer, pump, connections, or fuel level.
12. Install fuel regulator and fuel relief valve assembly (see Fig 5). **NOTE:** This item comes pre-assembled from the factory.
13. Install the 3/8" diameter copper line from the fuel relief valve to the fuel supply tank. Do not allow this line to protrude into the tank more than 1". This line should not be submerged in oil. Failure to install this line properly will result in damage to your boiler, and will void your warranty. The use of smaller line, or rubber, plastic or hydraulic line is unsafe and will void your warranty.
14. Install the fuel supply line from the fuel regulator/ relief valve assembly to the inlet port on the left side of the burner using 3/8" outside diameter copper tubing. **NOTE: THE MAXIMUM DISTANCE OF THIS LINE IS 25 FEET.**
15. If using copper line on the suction side of the pump, use flare fittings. Compression fittings may be used on the push side of the pump.
16. Keep the fuel supply lines 1" off any outside walls.

## Section 8 - Typical Boiler Piping

**Figure 6** Single Boiler Piping with Blend Pump

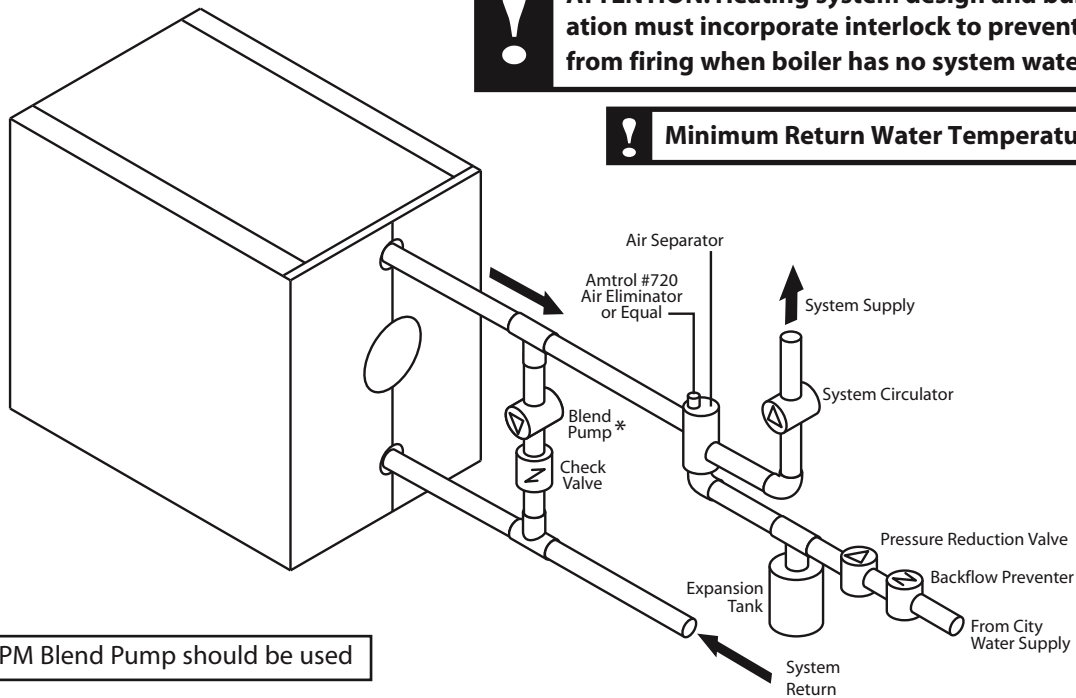

**ATTENTION:** Heating system design and burner operation must incorporate interlock to prevent burner from firing when boiler has no system water flow.



**Minimum Return Water Temperature 130 °F**

\*16.3 GPM Blend Pump should be used

**Figure 6B** Single or Multiple Boiler Piping for Primary/Secondary Pumping

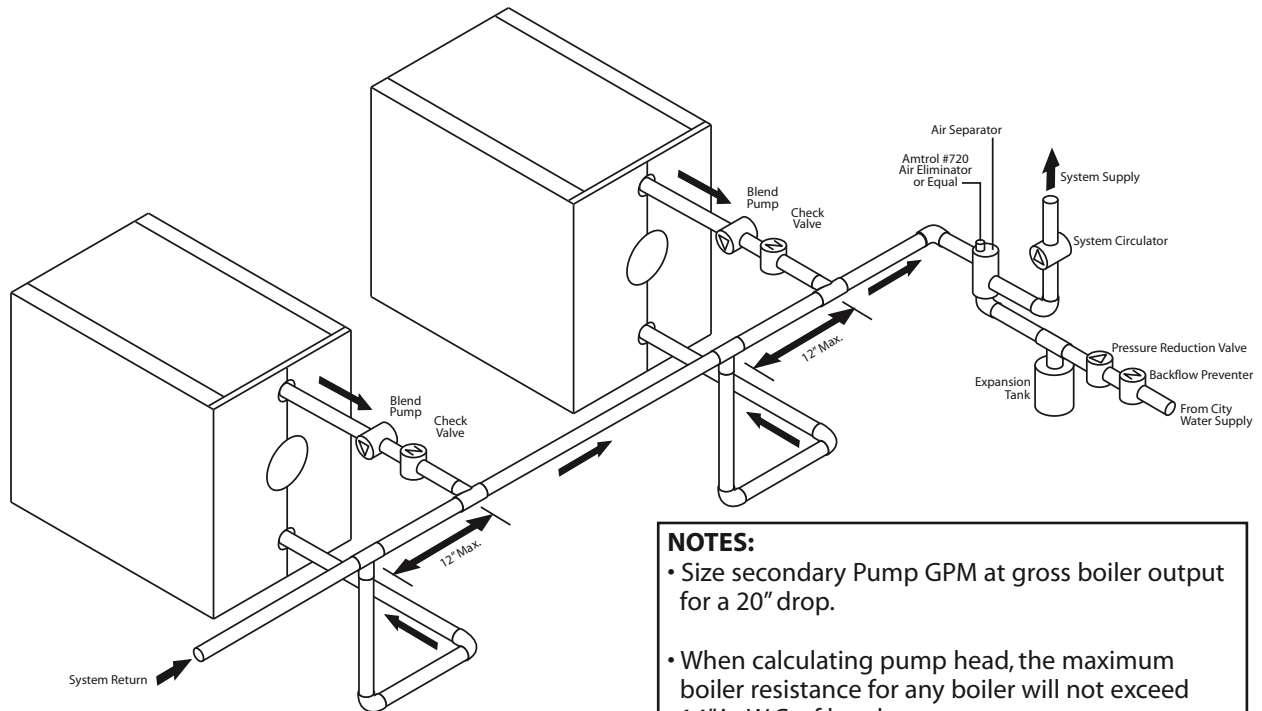

**NOTES:**

- Size secondary Pump GPM at gross boiler output for a 20" drop.
- When calculating pump head, the maximum boiler resistance for any boiler will not exceed 14" in W.C. of head



## Section 9 - Boiler Installation



**All MX Series boilers are shipped with the boiler sections assembled and hydrostatically tested to A.S.M.E. at the factory. Inspect boiler for any visible damage before beginning installation.**

### Inspect Shipment

Any claims for damage or shortage must be filed against carrier or consignee. No claims for variances from, or shortages in orders, will be considered unless presented 7 days after receipt of goods.

Boiler shipment comes in two separate pallets.

1. Wood pallet with:
  - Boiler block with insert installed
  - Box of jacket parts
  - Box marked #3 (Burner Assembly)
    - a) Complete Lanair MXB Burner assembly
    - b) Secondary Air Filter/Regulator
  - Box marked #4 (Accessories Box)
    - a) Oil filter, oil pressure gauge, oil supply line relief valve, and regulator assembly, plumbing kit and Instruction Manual/Warranty Card Packet
2. Boxes in the boiler chamber
  - Box marked #1 (Manifold Box)
    - a) Supply and return manifold, gaskets, 3/4" x 6" pipe, mounting studs, washers and nuts
    - b) Return diffuser and gaskets
    - c) Two (2) 3/4" male x female extension couplings for optional controls
  - Box marked #2 (Controls Box)
    - a) High Limit with 3/4" well and capillary clip
    - b) Temperature/Pressure Gauge
    - c) Relief Valve
    - d) Flame sight assembly
    - e) Four (4) spacers to secure back jacket panel
    - f) Burner mounting hardware
    - g) 1" to 3/4" reducer
    - h) Insulation and Mortar
  - Box marked #5 (Low Water Cut Out)
  - Chimney Adapter

### Placement

1. Move the boiler (in the crate) as close as possible to its final location. Boiler must be positioned on a proper load bearing concrete pad or floor. See Fig. 1, page 8 for typical boiler room layout.
2. Remove the lag screws (2) holding the rear feet to the skid.
3. Remove the front jacket panel. Cut the banding holding the front of the boiler to the skid.
4. Carefully move the boiler into its final position.



**INSTALLATION MUST BE DONE BY A LICENSED HVAC/HYDRONIC CONTRACTOR FAMILIAR WITH ALL STATE AND LOCAL CODES.**



## Section 9 - Boiler Installation



**Note: Threads used on the studs is metric. Any attempt to use standard (English) threaded studs in place of those supplied will damage the boiler block.**

**Figure 7**

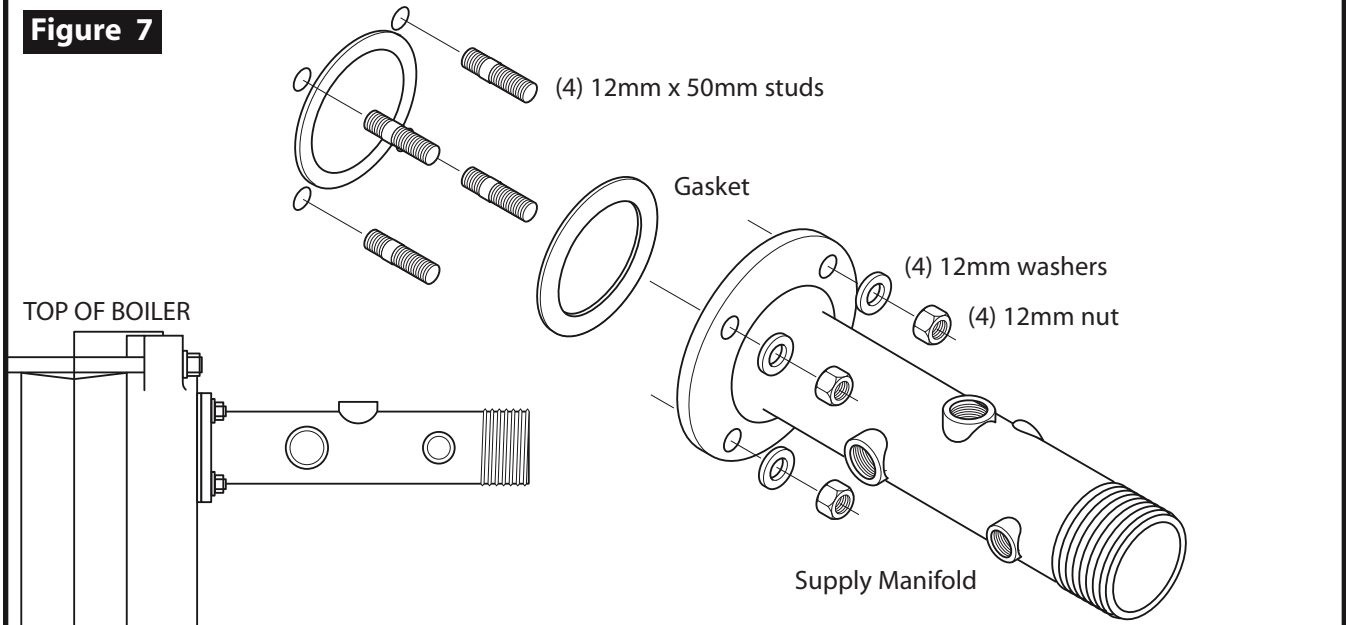

### Manifold and Diffuser Installation

1. Attach supply manifold as indicated in Fig. 7. Install return port diffuser and attach return flange as shown in Fig. 8.  
**NOTE: Make sure diffuser slots face upward (see Fig. 8).**

**Figure 8**

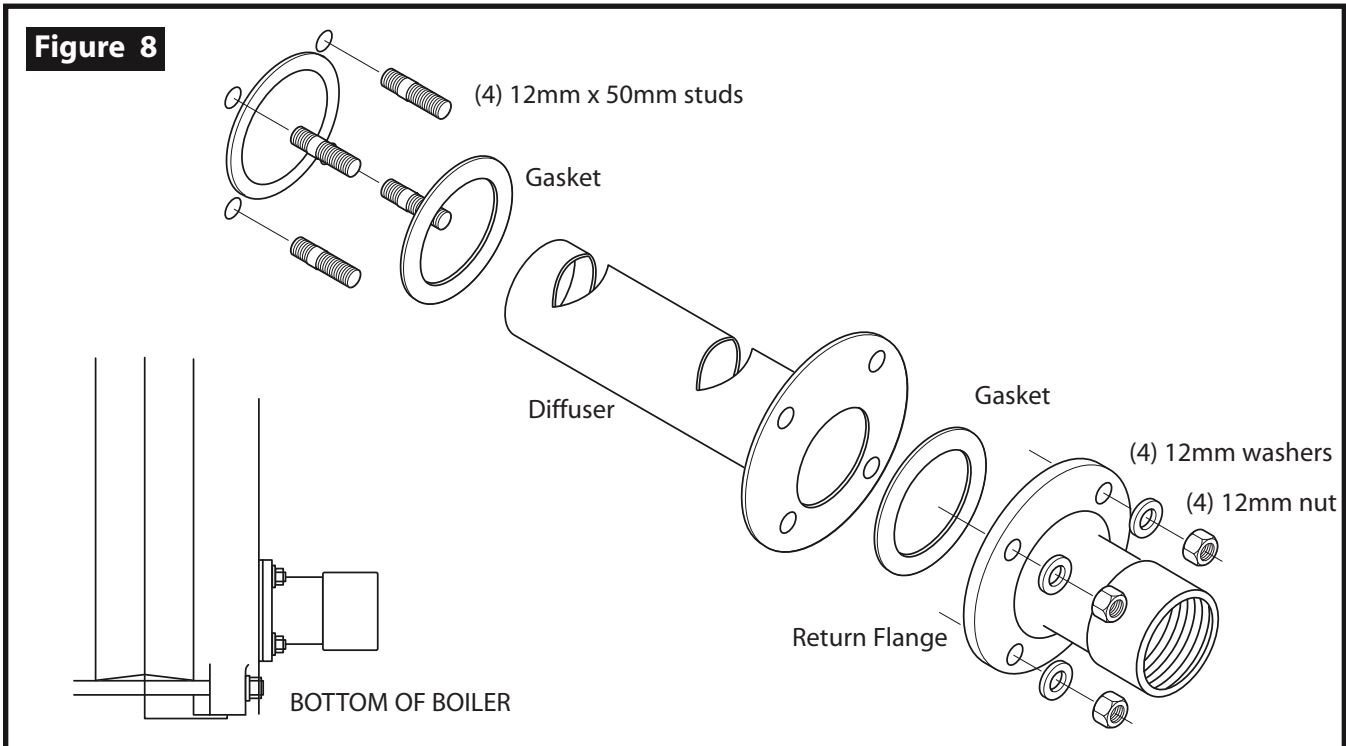

**Figure 9**

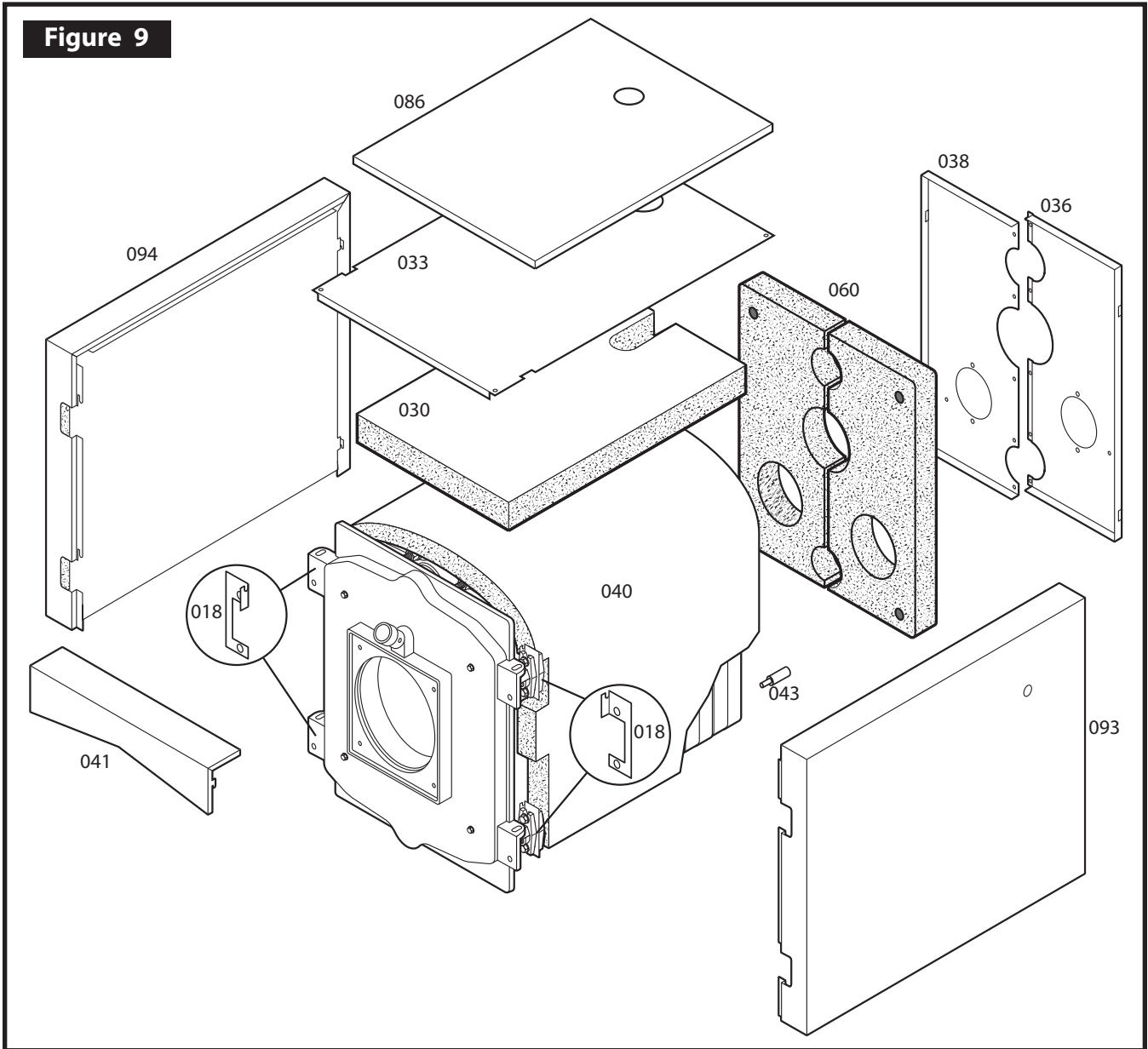

**ATTENTION: DO NOT INSTALL THE BOILER JACKET WITHOUT FIRST ATTACHING THE SUPPLY MANIFOLD AND DIFFUSER (SEE PAGE 17).**

**PARTS LIST**

- 018 HINGE BRACKET (factory mounted to boiler)
- 030 ADDITIONAL INSULATION
- 033 CENTER PANEL
- 036 RIGHT REAR PANEL
- 038 LEFT REAR PANEL
- 040 INSULATING MAT FOR BOILER SHELL (FOIL OUT)

- 041 UPPER FRONT TRIM PANEL
- 043 SETSCREW AF-17 AND SPACER (4 required)
- 060 REAR INSULATING MAT (2 PIECES)
- 086 TOP PANEL
- 093 RIGHT SIDE PANEL
- 094 LEFT SIDE PANEL

## Section 9 - Boiler Installation

### Boiler Jacket Installation

1. Screw the four (4) jacket extensions (043) into the four outer holes in the corners of the rear boiler section. Securely tighten the jacket extensions. Check other bolts on the rear panel and tighten if necessary.
2. Place the large wrap-around insulation blanket (040) over the boiler block. **NOTE:** The aluminum foil side of the blanket should be facing out.
3. Place smaller piece of insulation (030) on top of the insulation blanket. This will provide extra insulation on the top of the boiler block.
4. Remove flue collector clean-out covers (see illustration on page 7 for location).
5. Place rear insulation (060) on the rear panel. The holes of the insulation should align with the clean-out ports and the jacket extensions (043). Compress insulation until the jacket extensions (043) protrude. **NOTE:** The rear insulation is two separate pieces (right and left) Position with the aluminum foil side of the insulation facing out.
6. Align the right rear jacket panel (036) to the jacket extensions (043) and attach using two (2) M6 x 10 pan head screws provided. Align the left rear jacket panel (038) to the jacket extensions (043) and attach using two (2) M6 x 10 pan head screws provided. Align the corresponding holes of the right and left rear jacket panels and secure using five (5) sheet metal screws provided.
7. Re-attach the flue collector clean-out covers. **NOTE:** Do not over tighten bolts of the clean-out covers. Over tightening may crack or break the covers.
8. Attach the right (093) and left (094) jacket panels. Each panel attaches to the unit using the hooks on the factory-installed hinge brackets (018) at the front of the unit and the holes in the previously mounted rear panels.
9. Place the center panel (033), with flange edge down, between side panels.
10. Attach the upper front trim panel (041) between the right (093) and left (094) side panels. The front panel has hooks which are inserted into slots in the front of the side panels.
11. Align the hooks of the top panel (086) with those of slots on the top of the side panels. Place top panel between side panels and slide forward to lock in position.

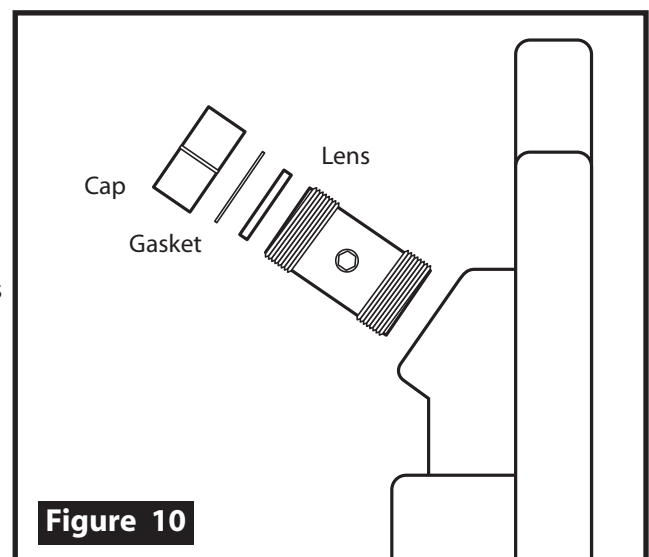
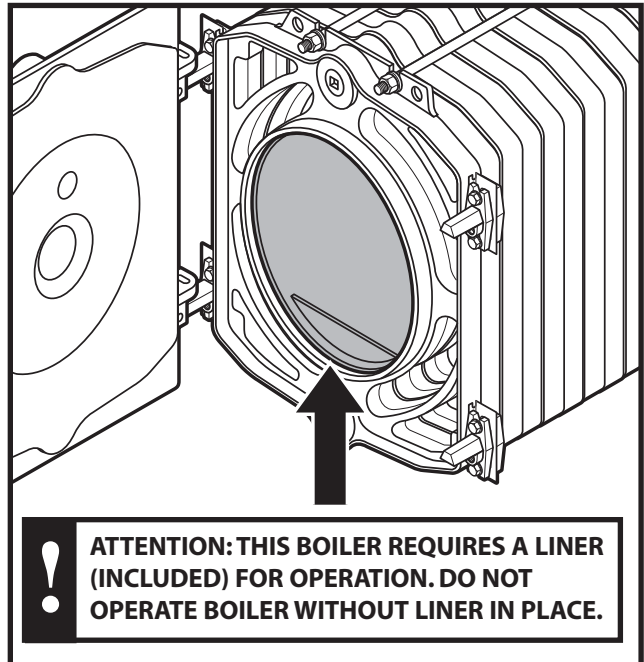

### Sight Glass Installation

1. Remove the sight glass plug on the door of the unit.
2. Install sight glass assembly. Hand tighten (Fig. 10).

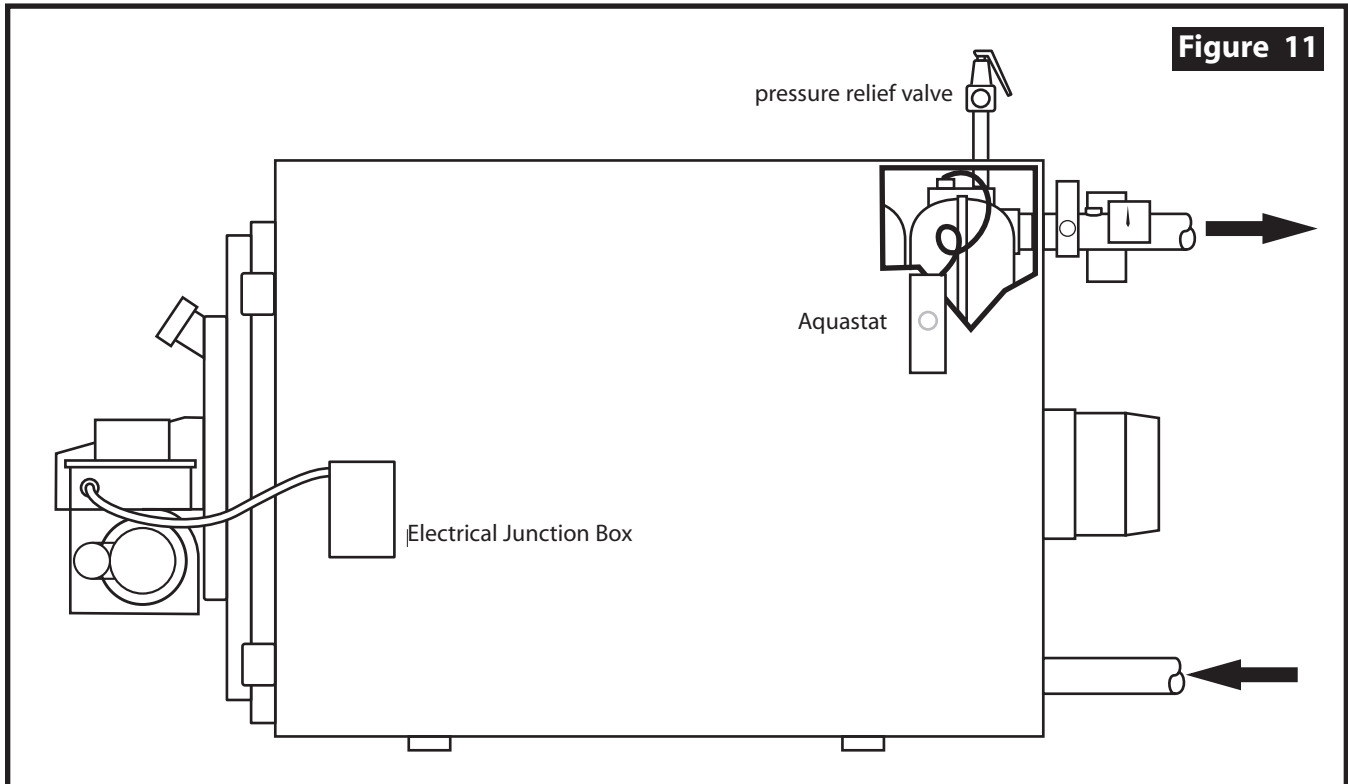

**Figure 11**



**INSTALLATION MUST BE DONE BY A LICENSED HVAC/HYDRONIC CONTRACTOR FAMILIAR WITH ALL STATE AND LOCAL CODES.**

### Boiler Controls and Accessory Location

1. Remove the top of the boiler jacket. Install 3/4" x 6" relief valve pipe to the top of the unit as indicated in Fig. 12. Pipe mounts to the 3/4" hole at the top rear of the boiler block.
2. Insert the sensor of the aquastat through the side of the boiler jacket. Mount the aquastat to the side of the boiler as indicated in Fig. 11.
3. Insert 1" to 3/4" reducer to boiler top and tighten. Insert sensor housing into reducer and tighten. Insert the sensor into the housing. **NOTE:** Sensor must be fully seated for proper operation.
4. Replace the top of the boiler jacket.
5. Attach the pressure relief valve to the previously attached 3/4" x 6" pipe and tighten.

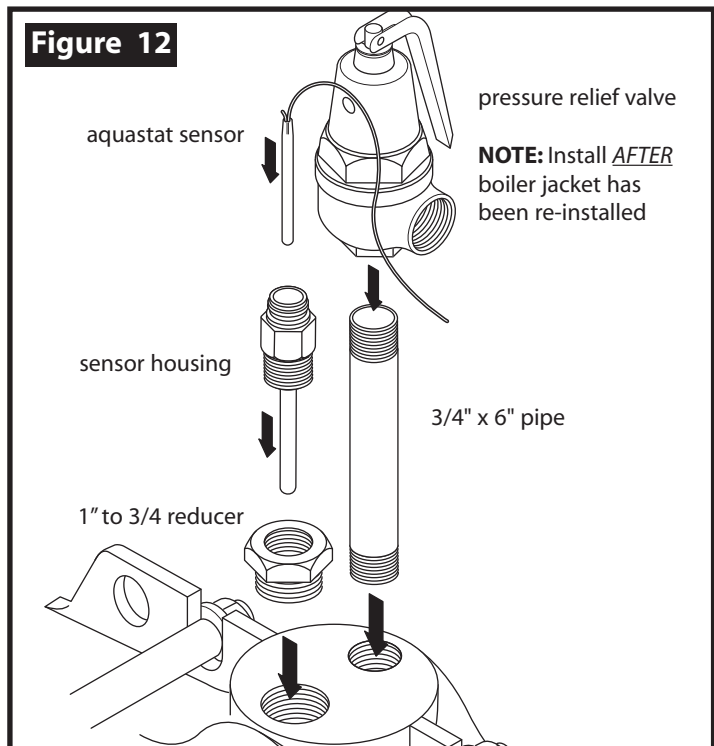

**Figure 12**

**NOTE:** Install *AFTER* boiler jacket has been re-installed

## Section 10 - Boiler Controls and Accessory Location



Discharge piping from pressure relief valve must be piped to a drain or must terminate 6" above floor to avoid damage to the structure or personal injury. It must **NOT** be piped to a point where freezing might occur.

**Figure 13**

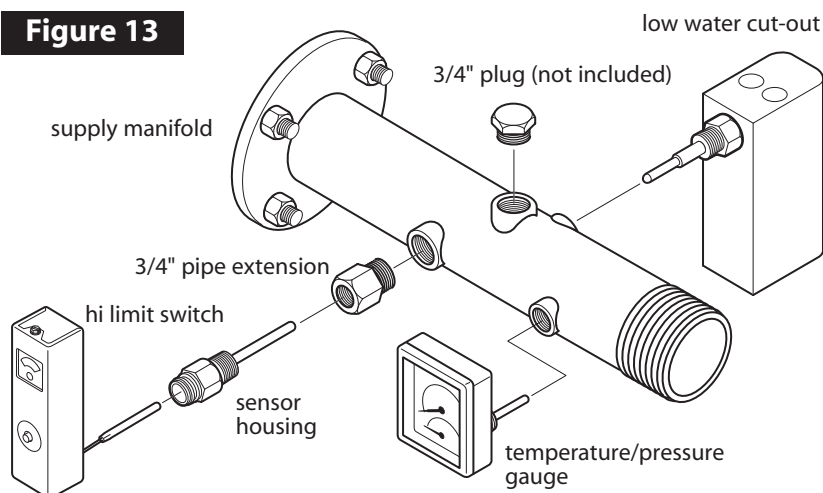

6. Install discharge piping from pressure relief valve.
7. Install 3/4" pipe extension to supply manifold. Attach sensor housing to the extension. Insert hi-limit sensor into housing and attach to the sensor housing.
8. Attach temperature/pressure gauge and low water cut-out to the supply manifold (see Fig. 13)
9. Insert 3/4" plug (not included) into top of manifold and tighten



If a blend pump is not used, consult your licensed hydronic contractor regarding system design. Minimum 130° return water required.

## Section 11 - Burner Installation

**Figure 14**

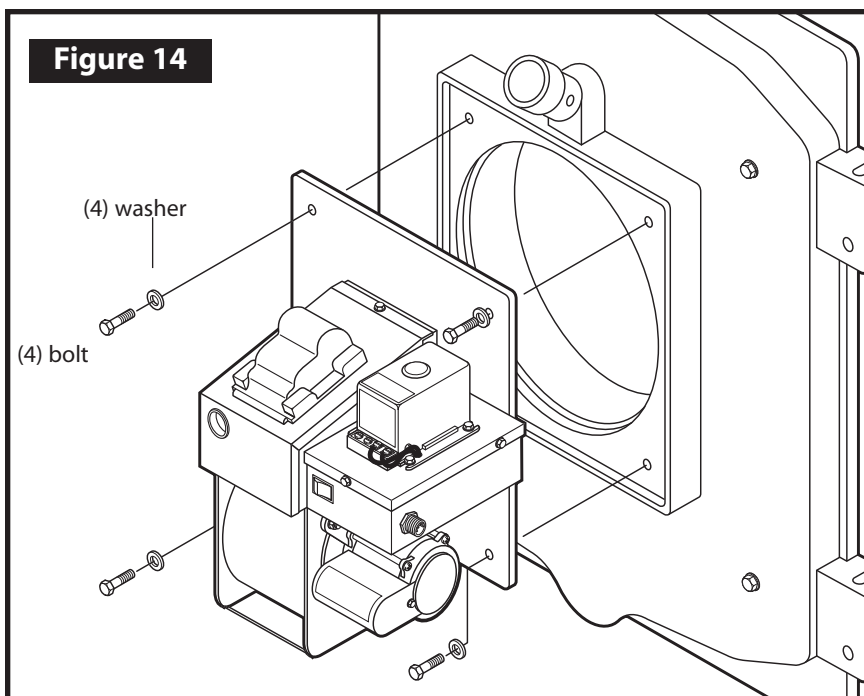

### Burner Installation

1. Unpack the burner and inspect for any signs of damage.
2. Remove cardboard insert from door front.
3. Position the burner to the door of the boiler and attach using four (4) bolts and washers provided (see Fig. 14).
4. After the burner is mounted, open the burner door, and seal the void between the burner door and the blast tube of the burner with the insulation and mortar supplied with the boiler.



## Section 12 - Electrical Connections

### **! CAUTION: HAZARD OF ELECTRICAL SHOCK!**

#### **Main Electrical Installation**

1. All wiring must comply with the National Electrical Code, State and Local Ordinances, and be wired by a qualified electrician.
2. Electrical service **MUST** be connected to a separate 20 AMP, 115 VAC, 60 HZ single phase circuit.
3. Electrical service connections are made in the electrical junction box on side of the boiler.
4. The boiler must have a safety equipment ground from the main electrical service, stranded 12 GA minimum.
5. The electrical conductors for electrical service to the heater **MUST** be stranded 12 GA minimum.
6. Install a manual service disconnect near the heater, and label its function.
7. The supply voltage must be maintained at a minimum 110 VAC.
8. The electrical conductors from the main electrical service must be within approved conduit.
9. Keep all electrical conductors and conduit away from the chimney connector as well as any other hot surfaces. Refer to Figure 15, Wiring Diagram for color code, etc. Keep the power off until the heater is ready to be started. Refer to Section 13 Start Up Procedure.

#### **Fuel Supply Pump Electrical Installation**

1. All wiring must comply with the National Electrical Code, State and Local Ordinances, and be wired by a qualified electrician.
2. The electrical conductors to the fuel pump motor **MUST** be stranded 14 GA minimum.
3. The electrical service connections for the fuel pump motor are made in the electrical junction box on the side of the boiler.
4. The pump motor **MUST** have a safety equipment ground from the main electrical service, stranded 12 GA minimum.
5. The electrical conductors from the electrical junction box to the pump motor must be within approved conduit.
6. Keep all electrical conductors and conduit away from the chimney connector as well as any other hot surfaces. Refer to Figure 15 Wiring Diagram for color code, etc. Keep the power off until the boiler is ready to be started. Refer to Section 13 Start Up Procedure.

#### **Hi-Limit Switch and Manifold Controls Electrical Installation**

**! ATTENTION! DUE TO VARYING SYSTEM DESIGNS, ONLY A CERTIFIED HVAC/HYDRONICS INSTALLER CAN DETERMINE THE PROPER WIRING OF THESE COMPONENTS.**

All wiring must comply with the National Electrical Code, State and Local Ordinances, and be wired by a qualified electrician.

## Section 12 - Burner/Pump Electrical Connections

**Figure 15**

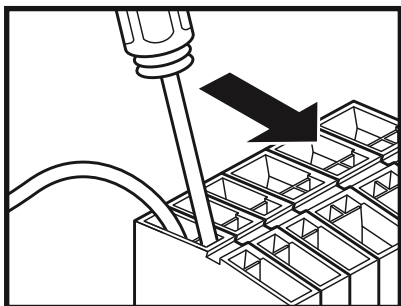

Remove wires from the block by inserting a flat tip screwdriver into the top slot. Push tip all the way down and push forward. Remove wire.

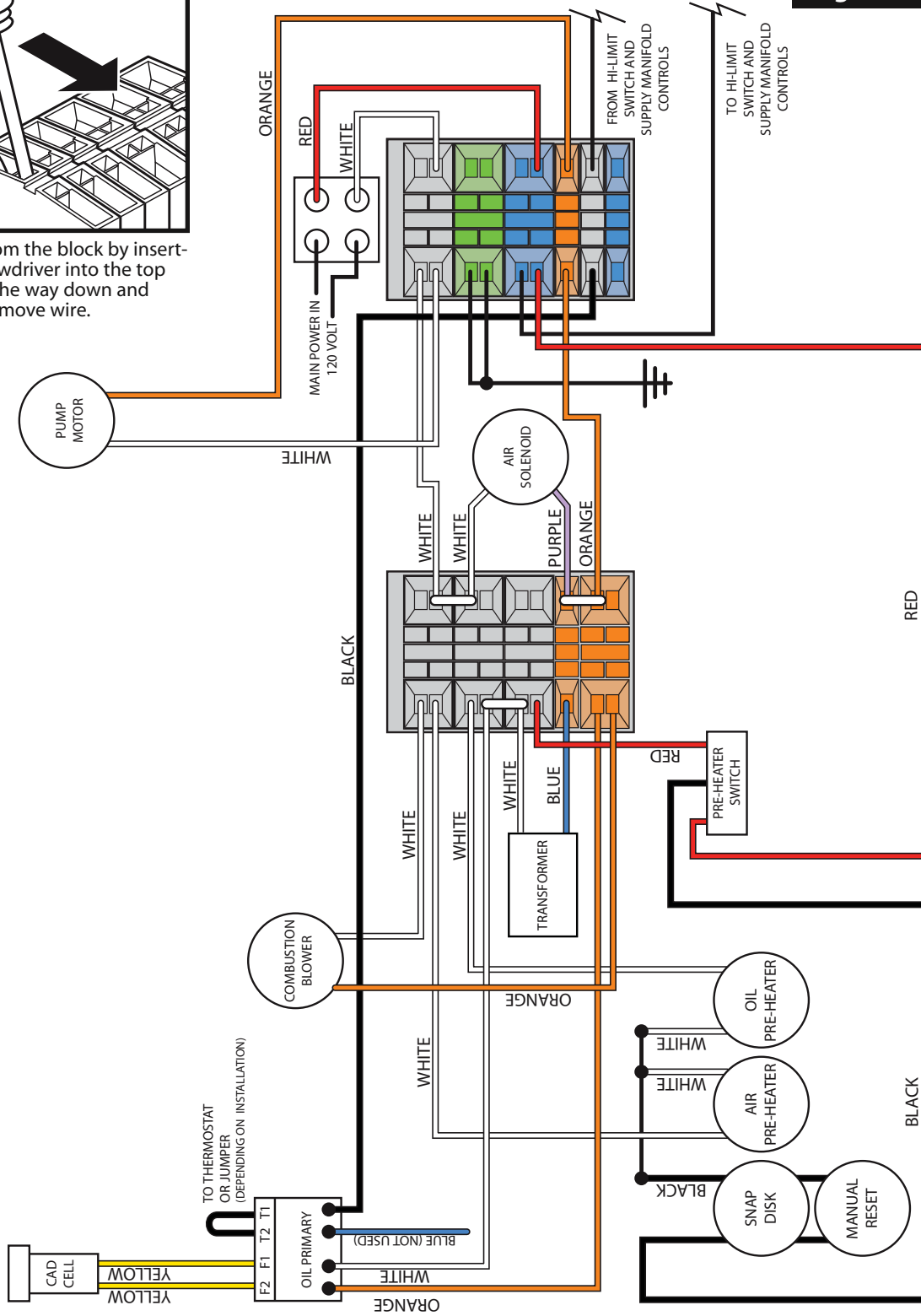



## Section 13 - Compressed Air Installation

### Compressed Air Supply Installation

1. Install an air pressure supply line connection to the air filter/regulator.
2. The air supply source must be capable of producing 1.0 CFM @ 100 PSI.
3. Install a shut off valve in the air supply line for service.
4. Install a **primary air filter/regulator with a gauge** (capable of reading line pressure) in the air supply line prior to the air filter/regulator mounted on the furnace. **THE PRIMARY AIR FILTER/REGULATOR IS NOT SUPPLIED WITH THE BOILER.**
5. If the primary air regulator does not have a filter with a bowl, a condensate drain leg must be installed in the air supply line.
6. Install a quick disconnect at the air filter/regulator on the boiler for service.
7. For the ease of installation install a flexible air line (.250 I.D. minimum) from the quick disconnect to the primary air regulator.
8. The air supply line must be pitched upward from the primary regulator to the boiler to prevent condensation from entering your burner.
9. Open all air shut off valves, and set the primary air regulator at 30 PSI.
10. Set the secondary air filter/regulator to 15 PSI.

**Figure 16**

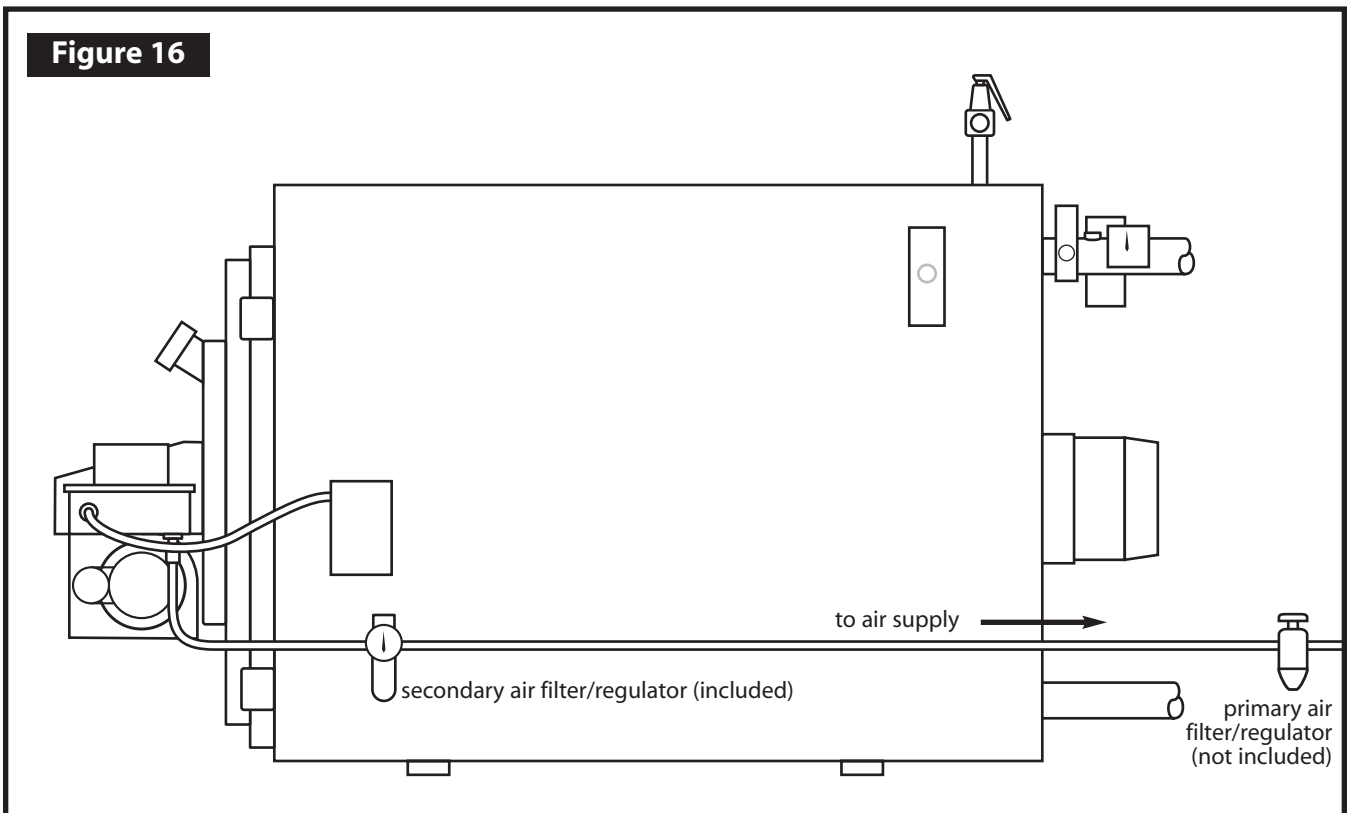



### Burner Controls and Operation

- **Oil Primary Safety Control/Cad Cell:**

The oil primary control is mounted on top of the burner's electrical box. When the thermostat calls for heat the oil primary control starts the burner by switching on the air solenoid valve, ignition transformer, combustion air blower, and the fuel pump. The oil primary control works in conjunction with the cadmium sulfide cell (cad cell). The cad cell is mounted inside the burner cover, and faces the flame. The cad cell monitors the light level inside the combustion chamber to insure there is a flame present. If there is a loss of flame the primary control will go into its recycle mode. After 1-2 minutes the primary control will restart the burner. When this happens if there is a flame present, the burner will continue to function. If on start up no flame is established in 30 seconds the primary control will lock out. CAUTION: Do not press the reset button more than twice. If the burner fails to start refer to Section 19, Trouble Shooting.

- **Barometric Draft Control:**

The Barometric Draft Control automatically maintains a pre-set chimney draft, and is located in the chimney connector (see page 10, Fig. 3). **NOTE:** The draft must be set/checked using a manometer.

- **Air Filter/Regulator:**

The Air Filter/Regulator performs two functions: 1. It removes condensation and dirt from the air. 2. It controls the amount of air pressure reaching the nozzle and air operated fuel valve. The Air/Filter Regulator is mounted on the cabinet near the burner.

- **Electric Air Solenoid Valve:**

The Electric Air Solenoid Valve is controlled by the Oil Primary Control. It acts as a shut-off valve, (it's open during operation, and closed when the burner is off). The Electric Air Solenoid Valve is located inside of the burner's electrical box.

- **Air Operated Fuel Valve:**

The Air Operated Fuel Valve controls fuel flow to the nozzle. When the Electric Air Solenoid Valve opens and air pressure pushes on the fuel valve diaphragm, the plunger moves off the nozzle seat allowing fuel to enter the nozzle. The Air Operated Fuel Valve is located on the back of the air pre-heater.

- **Air/Oil Pre-heater:**

The Air/Oil pre-heater is an assembly that preheats the atomizing air and fuel to a predetermined temperature to properly combust used oil. The Air/Oil pre-heater is located in the burner.

- **Snap Disc Assembly:**

The Snap Disc accurately controls the temperature of the air/oil pre-heater assembly with two resistance type cartridge-heating elements. The Snap Disc is mounted on the oil pre-heater inside the burner.

- **Nozzle:**

The Nozzle uses air pressure to help pull fuel through its small orifice, and to atomize the fuel for proper combustion. The Nozzle is located on the end of the air pre-heater opposite the fuel valve. Replace the Nozzle annually, as they are prone to wear by contaminants in waste oil/used oil.

### Fuel Pump Controls and Operation

- **Fuel Supply Pump:**

The Fuel Supply Pump pumps fuel from your oil storage tank to the burner. The Fuel Supply Pump should be located as close to the fuel supply tank as possible. The Fuel Supply Pump must be mounted horizontally (Shaft). See page 12, Fig. 4.



### Fuel Pump Controls and Operation

- **Fuel Regulator:**  
A Fuel regulator is used to adjust the fuel pressure of waste oil to the burner.
- **Fuel Relief Valve:**  
The fuel relief valve prevents excess pressure build-up in the fuel line upon burner shut-down.

### Boiler Controls and Operation

- **Hi-Limit Switch:**  
Hi-limit switches are immersion type devices for regulating the temperature of liquids in a boiler where temperature control is required. The Hi-limit switch is mounted to the supply manifold at the rear of the boiler (see page 21 for details).
- **Low Water Cut-Out:**  
The low water cut-out switch is located on the supply manifold at the rear of the boiler. This device will turn the system off if it senses low water levels or pressure. The low water cut-out switch is mounted to the manifold at the rear of the boiler (see page 21 for details).
- **Aquastat**  
The aquastat is an immersion type device for limiting the temperature of liquids in a boiler. The aquastat is mounted to the cabinet and the sensor is installed at the rear of the boiler next to the pressure relief valve (see page 20)
- **Pressure Relief Valve:**  
The Pressure Relief Valve is mounted to the top of the boiler near the rear. This valve is used to automatically or manually release excess pressure which may be present in the boiler. See page 20.
- **Temperature/Pressure Gauge:**  
This dual purpose gauge monitors supply temperature and pressure. The temperature/pressure gauge is mounted to the supply manifold at the rear of the boiler (see page 21).

## Section 15 - Start-Up Procedures

### Boiler Start-Up - Fill System

1. Fill boiler and system according to job specifications. System pressure should be set to have 5 PSI pressure at the highest point in the heating system. Boiler pressure gauge will indicate pressure relative to the height of water column from the boiler to the highest point, plus the additional 5 PSI.  
**Example:** To calculate cold fill pressure: Highest point in system is 40';  $40 \div 2.31 = 17.32$  (1 PSI = 2.31 ft w.c.)  
Add 5 PSI to 17.32 = 22.32 PSI; boiler pressure gauge will indicate 22.32 PSI (cold fill pressure)
2. Purge air from boiler and system . **WARNING: Never purge system while boiler is in operation or fill a hot/empty boiler with cold water**
3. Min Return water temperature 130 F°



**The expansion tank must be properly sized to system requirements. An undersized expansion tank will cause system water to be lost through the relief valve and make-up water to be introduced through the fill valve eventually causing mineral build-up in the boiler sections which could lead to eventual section failure.**

## Section 15 - Start-Up Procedures

### Waste Oil Burner Start-Up

1. Make sure the main electrical service for the heater is turned off, and locked out.
2. Fill the oil supply tank with an approved fuel to a level that is above the pick-up tube check valve.
3. Check for proper draft in the chimney. The draft must read  $-.02$  W.C. cold.
4. Make sure there is air pressure at the heaters air filter/regulator, set it at 15 PSI. Set the primary regulator on the air supply line to 30 PSI.
5. Set the fan/limit control slide switch to automatic.
6. Check the combustion air adjustment baffle for proper setting. Refer to Section 17, Flame Adjustment.
7. Set the room thermostat below room temperature (if applicable).
8. Turn the main electrical service ON.
9. Push the reset button on the oil primary control for 3 seconds.
10. Flip the lighted rocker switch for preheating on the burner electrical box to the ON position (pre-heater OFF the light is off, pre-heater ON the light is on.).
11. Prime the fuel supply pump. Refer to Section 16, Priming the Fuel Supply Pump.
12. If using waste 10W-50W oil or automatic transmission fluid for fuel, flip the pre-heater rocker switch on (light ON, and wait 5-7 minutes for the pre-heater assembly to reach operating temperature. **Leave the pre-heater switch OFF if using No. 1 or No. 2 fuel oil.**
13. Turn the room thermostat up above the room temperature (if applicable). The burner will now fire, check the sight glass on the rear of the burner also inspect the flame through the inspection port. Refer to section 17, Flame Adjustment pages 29-30.
14. Adjust the burner air filter/regulator to 15 PSI, and the primary air regulator to 30 PSI. **NOTE:** 15 PSI on the air filter/regulator is the starting point, you may need to adjust from there when setting the flame. See pages 29-30.
15. Adjust the fuel pressure gauge on the left side of the burner to read 3 - 3 1/4 Lbs for MXB 250; 3 1/4 - 3 1/2 Lbs for MXB 400. **NOTE** Adjust the knob on the fuel regulator clockwise to increase pressure, and counter clockwise to decrease pressure to the burner. The oil pressures listed above are a starting point, you may need to adjust from there when setting the flame. Refer to section 17, Flame Adjustment pages 29-30.
16. Adjust the barometric damper to obtain a draft of  $-.06$  W.C. while the heater is hot and operating. **NOTE:** It is VERY IMPORTANT that the barometric damper is set to the required settings to ensure the natural draft of exhaust gases. See Section 5, Draft , page 11.
17. Depending on the type of fuel used, the elevation, temperature, and oil viscosity, the combustion air baffle will need to be adjusted for optimum performance. Refer to section 17, Flame Adjustment pages 29-30.



**The combustion air baffle is NOT factory set**



## Section 16 - Priming the Fuel Pump

1. The fuel level in the supply tank must be above the check valve on the pick-up tube. Fill suction line with oil.
2. Remove the bowl of the suction line strainer, and fill with clean fuel. Replace the strainer bowl.
3. Remove the two yellow wires from the F-F terminal on the oil primary control (Fig. 17). Install a jumper wire between the F-F terminals (Fig. 18).
4. Adjust the air filter/regulator on the heater to -0- PSI.
5. Remove the fuel supply line from the burner and position a container to catch the fuel.
6. Loosen the bleeder screw on the pump one turn, and attach a piece of 3/16" ID clear plastic tubing. The tubing should be long enough to allow the fuel to be returned to the tank.
7. Turn the room thermostat above room temperature, or to the "ON" position.
8. Disconnect one end of the jumper wire at the F-F terminals on the oil primary. The fuel pump will now start.
9. Observe the clear tubing attached to the bleeder screw on the pump. When a steady stream of fuel (no air bubbles) flows close the bleeder screw. Remove the tubing from the bleeder screw.
10. Observe the end of the fuel supply line that is disconnected from the burner. Allow a steady stream (no air bubbles) of fuel to flow into the container for several minutes. This will flush any debris from the fuel line that could potentially plug the nozzle. The vacuum gauge reading should not exceed 5" HG of vacuum.
11. Turn the room thermostat below room temperature or "OFF". The fuel supply pump will now stop.
12. Reconnect the fuel supply line to the burner.
13. Remove the jumper wire from the F-F terminals on the oil primary control, reattach the yellow cad cell wires.
14. Adjust the burner air filter/regulator to 15 PSI.
15. If the fuel supply pump prime, or fuel stream has air in it (spurting, fluctuating flow) there is likely a leak in the suction side of the plumbing. Refer to section 19, Trouble Shooting. The burner should now be ready to fire.

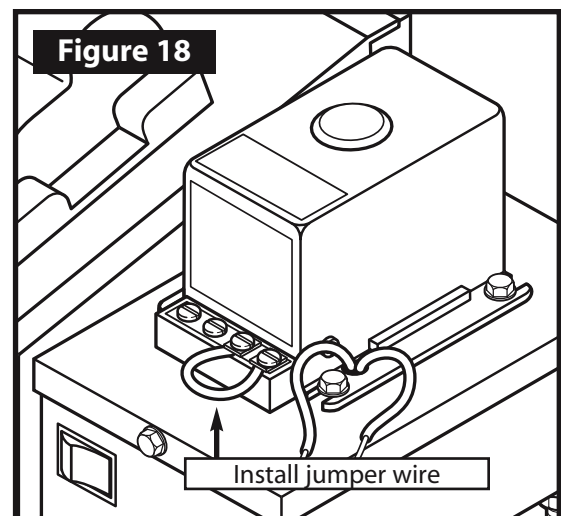
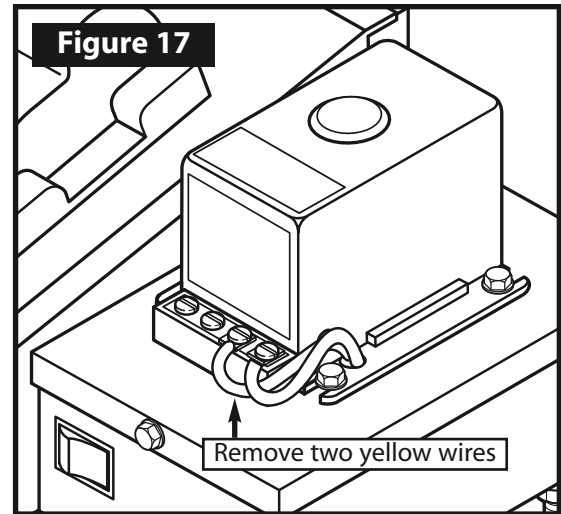

**ATTENTION: Never Touch a jumper wire from an "F" terminal to a "T" terminal. This will damage the Oil Primary Control.**

## Section 17 - Flame Adjustment

### Flame Adjustment

1. Start boiler, let it run for at least 45 minutes to reach operating temperature before proceeding.
2. Check chimney draft, set the barometric damper to -.06 WC when hot and running.
3. Check the atomizing air pressure, set the air filter/regulator on the heater to 15 PSI as a starting point.
4. Check the fuel pressure gauge on the burner, set to: MXB 250 3 - 3 1/4 Lbs; MXB 400 3 1/4 - 3 1/2 Lbs

Adjust the screw on the fuel regulator. Lock into position. The flame should extend no more than 3/4 of the way into the chamber.

**NOTE:** The above pressure is a starting point, depending on your installation you may need further adjustment.

5. Loosen the combustion air adjustment baffle, slowly close the baffle in 1/16" increments until the heater (flame) starts to rumble. Then slowly open the baffle in 1/16" increments until the rumbling stops, (wait 2 minutes between adjustments) finally open the baffle an additional 1/8" to provide excess oxygen. Secure the baffle, (See Fig 19).

**NOTE:** Mechanical equipment like gauges and regulators are not always 100 percent accurate,

6. Drill a hole in the smoke outlet transition piece and the damper and run combustion tests using combustion testing equipment.

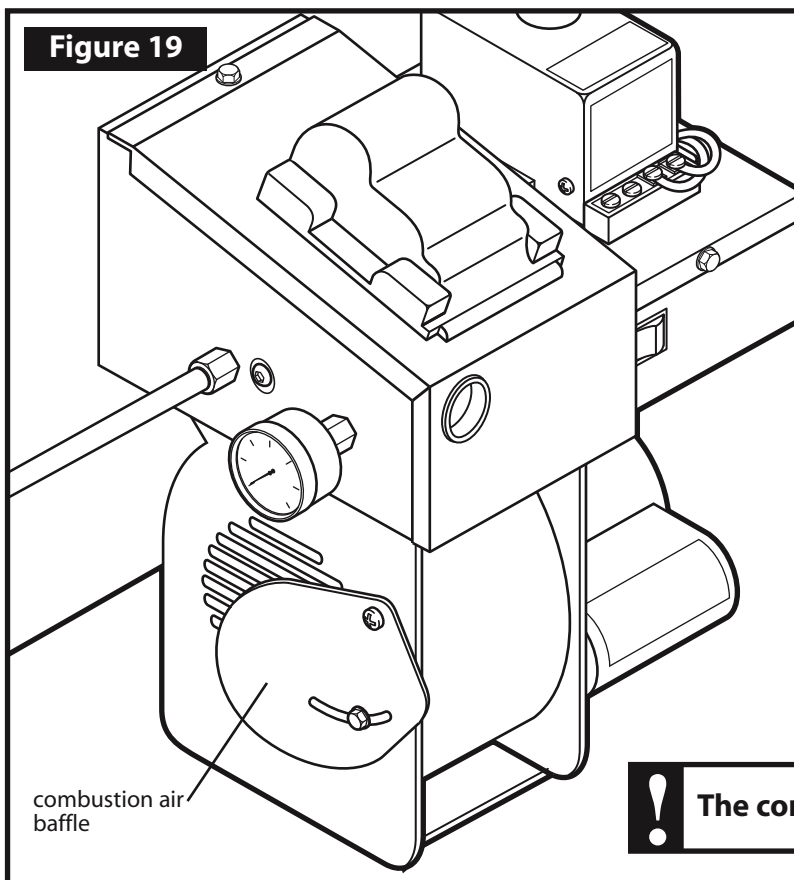

7. Adjust flame to achieve the following readings:

**CO<sub>2</sub>**; 12-15%

**Smoke**; 1-2 on the Bacharach Scale Oil Burner Smoke Scale with a maximum of 4.

8. Adjust the damper to have negative -.06 W.C. pressure (after 45 min. of operation) at the smoke outlet. Secure damper.
9. Seal combustion sample hole and smoke outlet connections using a high temperature silicone sealant. Also seal all breeching smoke pipe joints, seams and connections to the chimney.
10. After burner has been adjusted and while it is operating, check the front door for leakage of flue gas. Should leakage occur, tighten the door closure bolts. Also adjust door hinge bolts.



**The combustion air baffle is NOT factory set**

### Flame Adjustment - Visual

#### Flame is over-fired (Fig. 20).

- Dark yellow, to orange in color.
- The flame is hitting the walls, filling the chamber with a smokey flame. Correct immediately or chamber may be damaged.
- Decrease fuel pressure, and adjust combustion air baffle. Air pressure may also need to be adjusted.

**Problem:** Too large of a flame, dark yellow in color.

1. Too much fuel pressure.
2. Not enough combustion air.
3. Not enough atomizing air pressure.
4. Ash inside the chamber is dark brown to sooty black in color.

#### Flame is under-fired (Fig. 21).

- The flame is like a blow torch.
- Light yellow, to white in color.
- Flame is too short.
- Check to see if pre-heater block is hot.
- Check air PSI, it may be too high. Adjust in 1 LB. increments.
- Oil pressure and the combustion air baffle may need adjustment.

**Problem:** Too small a flame, similar to a blowtorch.

1. Too much atomizing air pressure.
2. Too much combustion air pressure.
3. Not enough fuel pressure.

#### Solutions:

1. Correct fuel pressure setting.
2. Flame tips reach 3/4 of the way into the chamber.
3. Flame has slightly yellow/orange tips.
4. No black smoke coming from the chimney.
5. Ash inside the chamber is white to off white in color.

#### Flame is full (Fig. 22).

- Bright yellow in color.
- Flame extends 3/4 into the chamber.
- Flame is not impinging on the chamber walls.

If you need assistance with flame adjustment, please call Lanair's Parts and Service Department.



Figure 20

#### BAD FLAME

The flame is too big, creating an over-fire condition

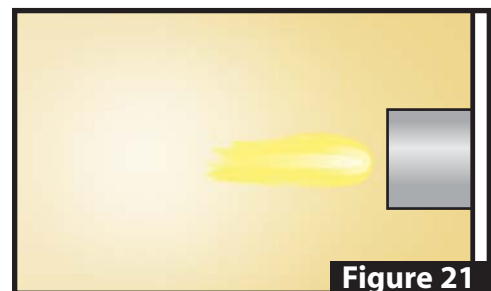

Figure 21

#### BAD FLAME

The flame is too short



Figure 22

#### GOOD FLAME

The flame length is approximately 3/4 of the chamber



**DO NOT OVER FIRE YOUR BOILER. IMMEDIATELY ADJUST THE BURNER TO THE PROPER FLAME LENGTH TO PREVENT DAMAGE TO YOUR BOILER.**



**CHECK FLAME DAILY (see page 31). ADJUST ACCORDINGLY**

## Section 18 - Service / Maintenance

### MX SERIES BOILER SERVICE / MAINTENANCE SCHEDULE

DAILY	WEEKLY	MONTHLY	ANNUALLY (Season Shut Down)
<ul style="list-style-type: none"> <li>• Check fuel supply tank level.</li> <li>• Check vacuum gauge reading on suction line. See Section 19.</li> <li>• Check atomizing air pressure at the air filter/ regulator. Set to 15 psi. Drain water from the bowl if necessary</li> <li>• Check the fuel pressure gauge on the burner. set to the correct pressure for the fuel being used.</li> <li>• Visually inspect flame. Adjust accordingly.</li> <li>• Check draft using a manometer. Set draft to -.02 cold, -.06 hot.</li> <li>• If boiler is not to be used for an extended period of time, flip the pre-heater rocker switch off (light off).</li> </ul>	<ul style="list-style-type: none"> <li>• Drain water/ anti-freeze from the fuel supply tank.</li> <li>• Check the air pressure setting on the primary air regulator. Set to 30 psi.</li> <li>• Drain water from the air pressure supply line drain leg and primary regulator.</li> </ul>	<ul style="list-style-type: none"> <li>• Check the combustion chamber flue passages. Clean if needed (see page 32).</li> <li>• Clean the chimney, chimney connector and barometric damper.</li> <li>• Clean pump strainer, suction line strainer and pick-up tube strainer (pp 33). <b>NOTE:</b> Always prime pump after cleaning strainers.</li> <li>• Check for dirt build-up on the combustion blower wheel. Keep wheel clean.</li> <li>• Inspect the combustion chamber, ash build-up, and flame.</li> </ul>	<ul style="list-style-type: none"> <li>• Shut off main power supply to boiler.</li> <li>• Perform monthly service/maintenance.</li> <li>• Flip air/fuel pre-heater switch off.</li> <li>• Shut off air supply.</li> <li>• Remove air/fuel pre-heater assembly. Disassemble and clean. Replace all o-rings (pp. 34, 35).</li> <li>• Remove air turbulator and clean (pp. 34, 35).</li> <li>• Replace nozzle and quad ring (pp. 34, 35 ,39)</li> <li>• Replace Ignitor (pp 38).</li> <li>• Adjust turbulator (pp 38).</li> <li>• Lubricate all motors following specifications on the motor rating plate.</li> <li>• Clean fuel pump strainer (see pp 33).</li> <li>• Drain and clean fuel supply tank.</li> <li>• Clean combustion blower.</li> </ul>



**NOTE: ALWAYS WEAR EYE, FACE AND BREATHING PROTECTION AND PROTECTIVE CLOTHING WHEN INSPECTING OR CLEANING CHAMBER OR ADJUSTING FLAME.**





## Section 18 - Service / Maintenance



**NOTE: ALWAYS WEAR EYE, FACE AND BREATHING PROTECTION AND PROTECTIVE CLOTHING WHEN INSPECTING OR CLEANING CHAMBER.**



**WARNING: DISCONNECT ALL ELECTRICAL POWER TO BOILER BEFORE SERVICING!**

### Flue/Combustion Chamber Cleaning

1. The boiler core must be completely cool to the touch before attempting to clean.
2. Turn off all power to the boiler (120 VAC) at the main disconnect.
3. Turn off air pressure supply
4. Disconnect power line from burner (Quick Disconnect cable from service box to burner).
5. Disconnect air line from burner.
6. Remove bolts from the boiler door. Carefully swing the boiler door open.
7. Remove smoke pipe and clean out port covers at rear of the boiler.
8. Using a cleaning brush, scrub all fire side surfaces in combustion chamber, flue passages and flue collector areas.
9. Use an industrial type canister vacuum cleaner with a high efficiency filter to remove any ash from the chamber or flue passages. Failure to clean flue passages will impair draft.
10. Inspect the combustion chamber and flue passages.
11. Re-connect smoke pipe and reinstall clean out port covers at rear of the boiler. **NOTE:** Do not over tighten bolts of the clean-out port covers. Over tightening may crack or break the covers.
12. Check the front door and flue collector rope seals. Replace as required.
13. Re-assemble boiler door and burner connections.

**IMPORTANT: When boiler is to be layed-up at the end of the heating season or out of service for a prolonged period of time:**

- A) Make sure all boiler surfaces are clean and dry.
- B) Open boiler front door and place a tray of calcium chloride in the center of the furnace. This will absorb moisture and keep the heat transfer surfaces dry. When calcium chloride becomes mushy, replace with new.
- C) Block the door approximately 1/4 open.



## Section 18 - Service / Maintenance

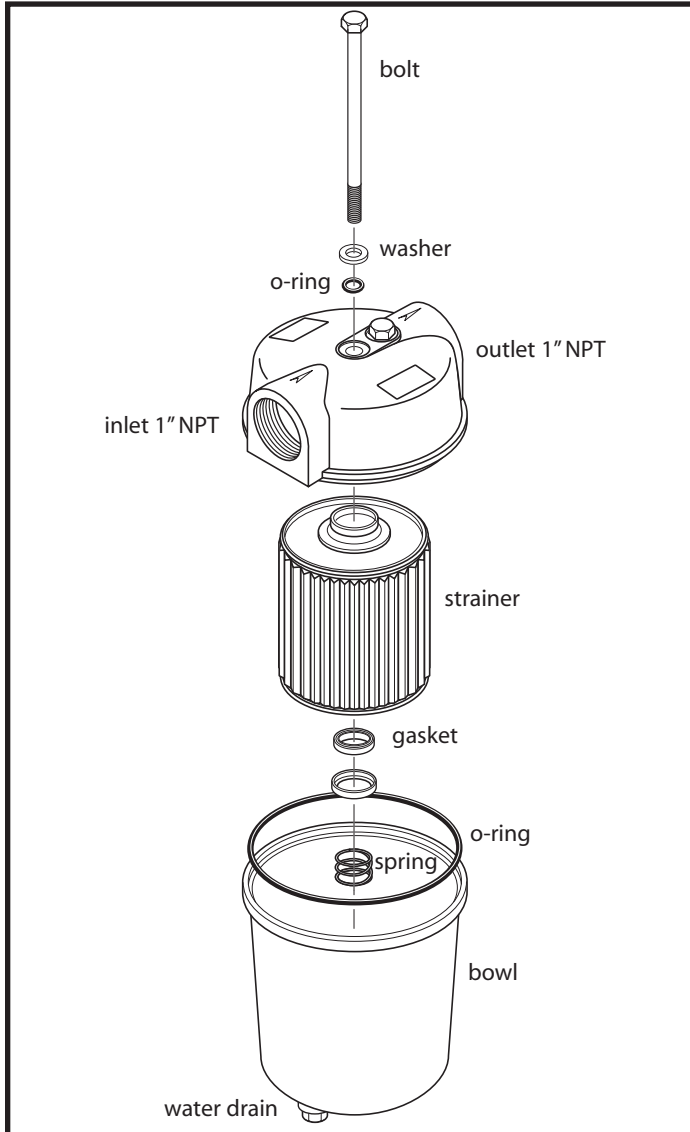

### Cleaning Suction Line Strainer

The suction line strainer should be cleaned every 30 days of operation. The element is a washable metal element. If your waste oil is extremely dirty, this strainer may need to be cleaned more frequently. Your vacuum gauge will help you determine when the filter needs cleaning. The vacuum gauge reading should not exceed 5" HG of vacuum. If it does, the strainer needs cleaning.

1. Disconnect power to the boiler.
2. While holding the lower housing, unscrew the center bolt on the top of the suction line strainer.
3. Rinse the filter and lower housing in solvent.
4. Air dry the strainer and lower housing.
5. Re-assemble the strainer, ensuring the rubber gaskets, spring and o-rings are in place.
6. Fill the lower housing with waste oil or fuel oil.
7. Position the lower housing to the top making sure the o-ring is properly seated. Secure the top and bottom together using the bolt, washer and gasket removed earlier.
8. Prime the fuel pump (see page 28).

### Cleaning/Replacing Fuel Pump Strainer

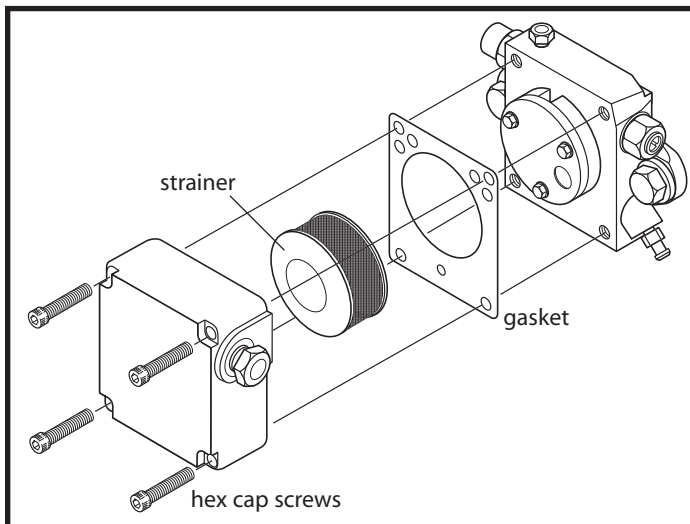

1. Disconnect power to the boiler.
2. Remove four hex head screws from pump cover. Carefully remove cover, strainer and gasket.
3. Clean housing, strainer and pump surface. Check for excess wear.
4. Install a new gasket (P/N 9817).
5. Install strainer and pump housing.
6. Prime the fuel pump (see page 28).

## Annual Maintenance - Air Pre-Heater

**Air Pre-Heater Tune-Up Kits (PN# 9870 & 9871) Required.**

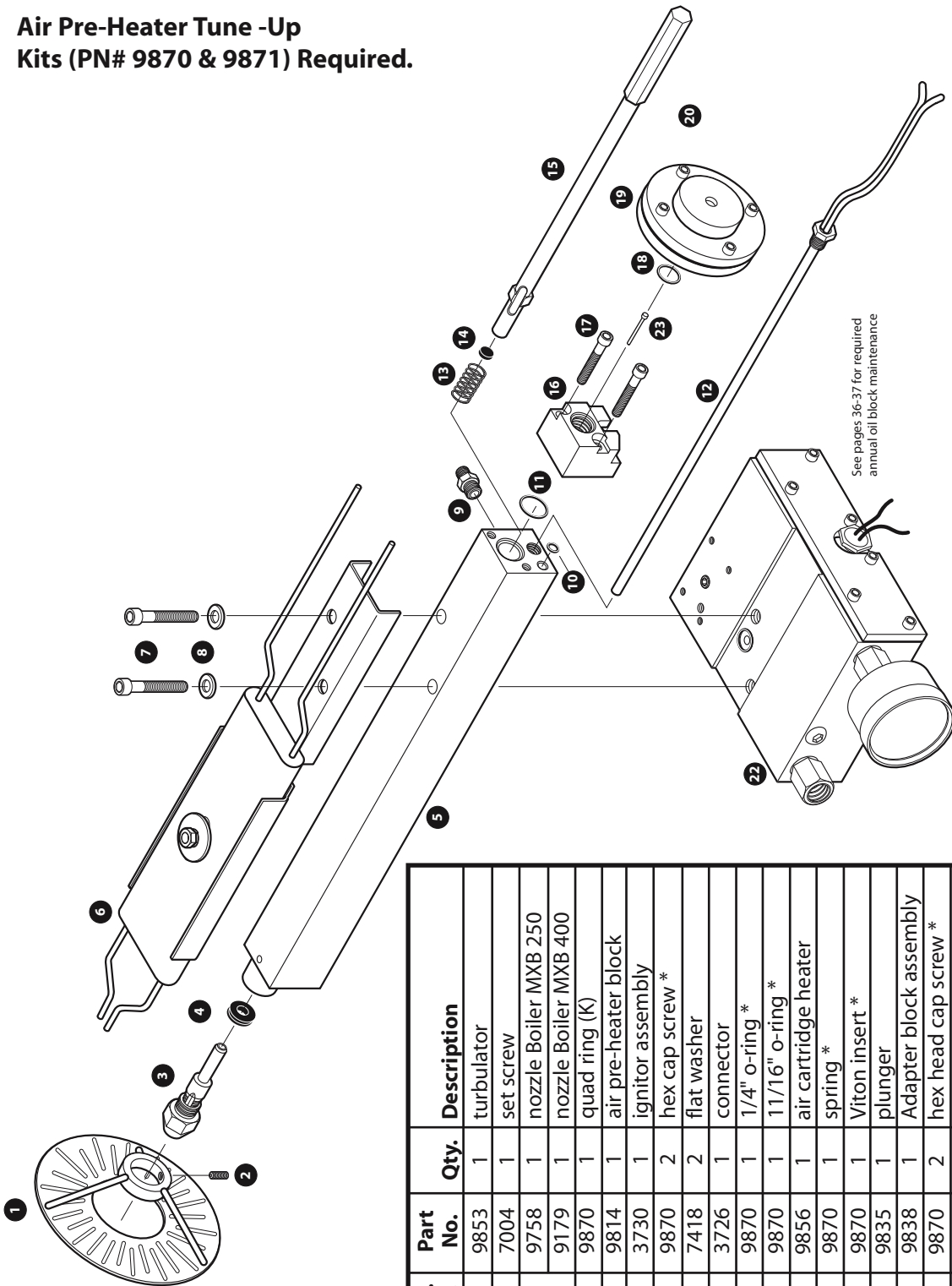

See pages 36-37 for required annual oil block maintenance

\* contained in tune up kit 9870  
 \*\* contained in tune-up kit 9871

Ref. No.	Part No.	Qty.	Description
1	9853	1	turbulator
2	7004	1	set screw
3	9758	1	nozzle Boiler MXB 250
	9179	1	nozzle Boiler MXB 400
4	9870	1	quad ring (K)
5	9814	1	air pre-heater block
6	3730	1	ignitor assembly
7	9870	2	hex cap screw *
8	7418	2	flat washer
9	3726	1	connector
10	9870	1	1/4" o-ring *
11	9870	1	11/16" o-ring *
12	9856	1	air cartridge heater
13	9870	1	spring *
14	9870	1	Viton insert *
15	9835	1	plunger
16	9838	1	Adapter block assembly
17	9870	2	hex head cap screw *
18	9871	1	1/2" o-ring (K)
19	9871	1	diaphragm assembly **
20	9871	2	hex head cap screw **
22			oil pre-heater block
23			Injector Pin

## Section 18 - Service / Maintenance

### 1. Remove Pre-Heater Assembly

- Disconnect the air line from the brass fitting on the air pre-heater and then from the air solenoid and remove.
- Disconnect wiring from the oil pre-heater cartridge, air pre-heater cartridge and snap disc assembly in the wiring junction box.
- Disconnect fuel line and fitting (6) from the oil block (5).
- Disconnect fuel pressure gauge (8) and fitting from the oil block (5).
- Remove button hex screw (14) and washer (11).
- Lift pre-heater assembly and carefully pull straight back. Remove entire assembly from the burner.
- Remove ignitor assembly (6).

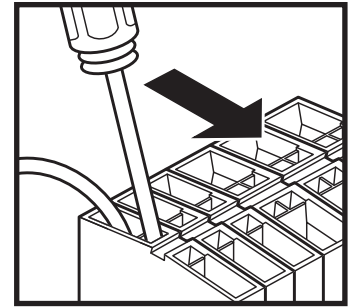

Remove wires from the block by inserting a flat tip screwdriver into the top slot. Push tip all the way down and push forward. Remove wire.

### 2. Remove Diaphragm Assembly from Air Pre-Heater

- Carefully place pre-heater assembly in a vice. **NOTE:** Do not damage pre-heater.
- Unscrew diaphragm assembly (19) from air pre-heater and set aside. Remove o-ring and discard.

### 3. Remove Adapter Assembly

- Remove hex cap screws (17) and set adapter assembly aside.

### 4. Remove Plunger , Spring and Cartridge Heater

- Remove spring (13) from plunger (15) and discard.
- Using a hook or screwdriver, carefully remove Viton insert (14) and discard.
- Remove and discard 1/4" o-ring (10) and 11/16" o-ring (11).
- Loosen and remove cartridge heater and set aside.

### 5. Remove Nozzle Assembly and Quad Ring

- Remove nozzle assembly (3) using a 9/16" wrench.
- If quad ring (4) does not come out with nozzle, carefully remove it and discard.

### 6. Clean all parts using a parts washer

- All passages must be thoroughly cleaned with a brush.

### 7. Replace Nozzle Assembly and Quad Ring

- After cleaning air pre-heater assembly, blow dry.
- Install new quad ring (4). Before inserting quad ring in air pre-heater block, a light coat of oil should be applied. **NOTE: Make sure quad ring is properly seated in block before proceeding (see page 39 for clarification).**
- Apply a light coat of oil to the shaft of the new nozzle assembly (3). Carefully insert new nozzle assembly (3) through the quad ring and into the block. Hand tighten until snug.
- Check alignment of ignitors and adjust if necessary (see page 38).

### 8. Replace O-rings and Plunger

- Insert a new 1/4" o-ring (10) and a new 11/16" o-ring (11) into the air pre-heater block (5).
- Insert new Viton insert (14) into the end of the plunger (15) and place new spring (13) on the end of the plunger. Insert plunger into air pre-heater block spring end first.

### 9. Replace Cartridge Heater

- Apply pipe dope to cartridge heater threads. Insert cartridge heater into air pre-heater block and tighten.

### 10. Replace Adapter Assembly

- Align the holes of the adapter assembly (16) with those on the air pre-heater block (5). **NOTE:** Make sure the small end of the adapter pin is facing toward the air pre-heater block.
- Attach the Adapter assembly (16) to the block using two hex cap screws (17). Tighten screws.

### 11. Replace Diaphragm

- Replace diaphragm, o-ring and spring (see page 39) Re-attach diaphragm assembly and hand tighten. **NOTE: Do not over tighten.**

### 12. Replace Ignitor Assembly (see page 39)

### 13. Service Oil Pre-Heater (see pages 36-37 for Annual Maintenance Instructions)

### Annual Maintenance - Oil Pre-Heater

**Oil Pre-Heater Tune-Up  
Kit (PN# 9869) Required.**

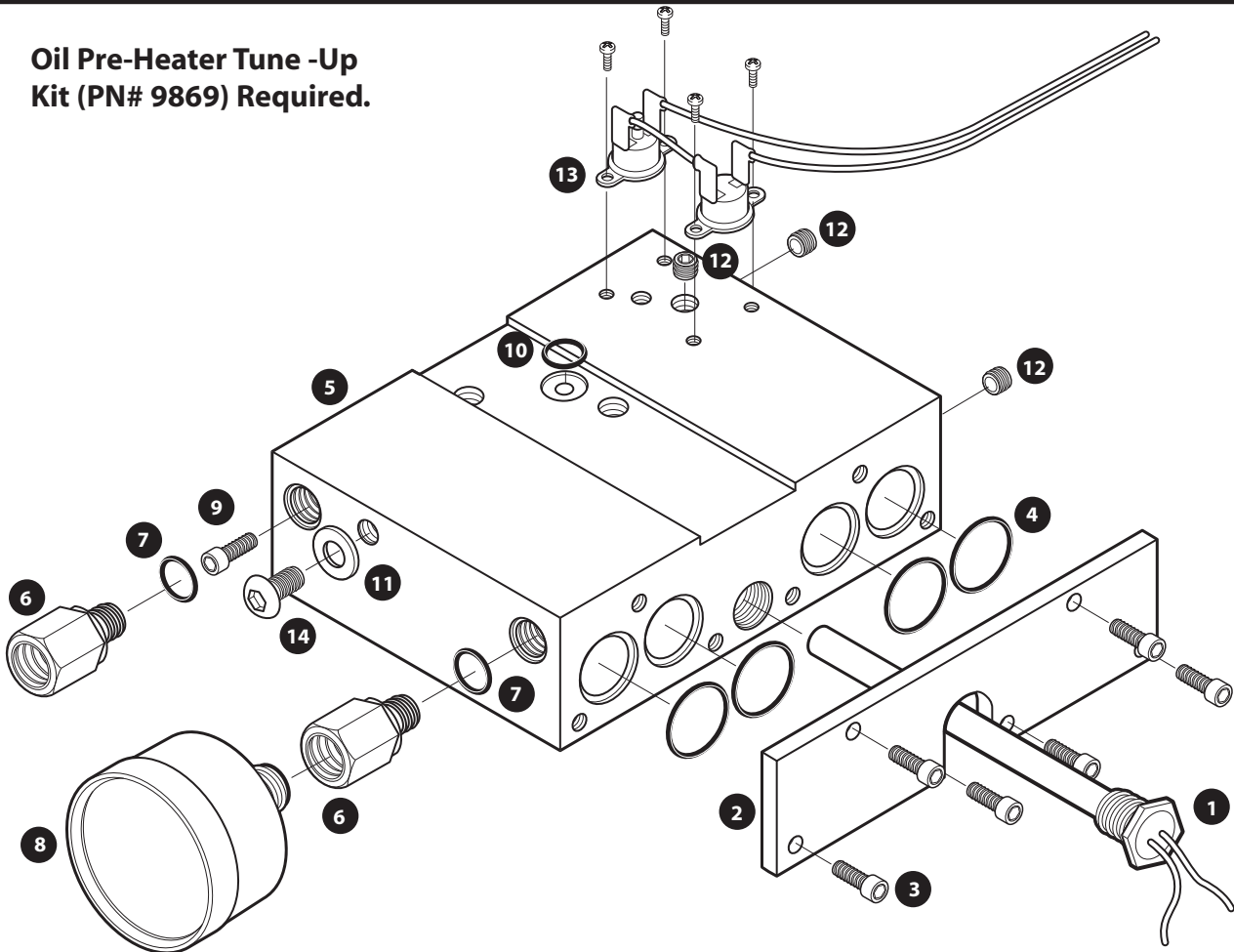

Ref. No.	Part No.	Qty.	Description
1	8992	1	cartridge heater
2	9813	1	pre-heater face plate
3	9869	6	hex cap screw *
4	9869	4	o-ring 13/16" OD *
5	2901	1	oil block
6	9029	2	fitting
7	9869	2	o-ring 5/16" OD *
8	8499	1	oil gauge
9	7242	1	hex cap screw
10	9869	1	o-ring 1/2" OD *
11	7418	1	washer
12	7109	3	plug
13	9366	1	snap disc assembly
14	7242	1	button hex screw

\* contained in tune up kit 9869

## Section 18 - Service / Maintenance

### 1. Separate Air Pre-Heater from Oil Pre-Heater

- Remove o-ring and discard(10).

### 2. Disassemble Oil Pre-Heater

- Remove o-ring and discard(10).
- Remove six hex cap screws (3) from face plate (2) and discard.
- Remove oil cartridge heater (1).
- Remove four 13/16"OD o-rings and discard(4).
- Remove three plugs (12) from oil block (5)
- Remove hex cap screw (9) from inside oil pre-heater block and clean. **NOTE:** Do not discard (5).

### 3. Clean Oil Pre-Heater Block

- Clean oil pre-heater block using a parts washer and brush. **NOTE:** Make sure all passages are clean.
- Blow dry the oil pre-heater block. inspect **ALL** passages making sure they are clear and clean.

### 4. Reassemble Oil Pre-Heater

- Replace four 13/16" OD o-rings (4) with new.
- Replace cartridge heater. **NOTE:** Do not over-tighten.
- Re-attach face plate (2) using six new hex cap screws (3) provided with tune-up kit (P/N 7240).
- Apply loc-tite to three block plugs (12) and replace.
- Replace hex cap screw (9) inside oil pre-heater block (5).
- Replace o-ring (10) with new.

### 5. Attach Air Pre-Heater Assembly

- Align the holes of the ignitor assembly and air pre-heater with those of the oil pre-heater (see page 34).
- Attach air pre-heater assembly to the oil pre-heater block (5) using two hex cap screws. Tighten securely.

### 6. Re-install Pre-Heater Assembly

- Place the air/oil pre-heater assembly into the burner body.
- Align the holes of the pre-heater assembly with those in the burner body.
- Secure the assembly to the body by re-installing the button hex screw (14) and washer (11). **NOTE:**Do not tighten this screw at this time.
- Replace the o-rings (7) on the PSI gauge and the oil line fittings (6) with new. **NOTE:**Do not tighten these fittings at this time.
- Adjust the pre-heater assembly for proper setting. The end of the turbulator should be recessed approximately 1/4" into the burner tube (see page 38 for turbulator adjustment).
- Once adjusted tighten button hex screw (14) and fittings (6)securely.

### 7. Re-connect Electrical

- Re-connect all wires previously disconnected in the electrical junction box (refer to wiring diagram, page 23 and the burner reference diagram, page 43).

### 8. Reconnect PSI Gauge, Fuel Line and Air Line

- Reconnect the PSI gauge (8) to the fitting (6) and tighten securely.
- Reconnect the fuel line to the fitting (6) and tighten securely.
- Reconnect the air line by connecting the one end of the air line to the air solenoid and the other end to the air fitting (see page 34).

### 9. Test Operation

- Follow start-up procedure, page 26.

### Ignitor Replacement / Adjustment

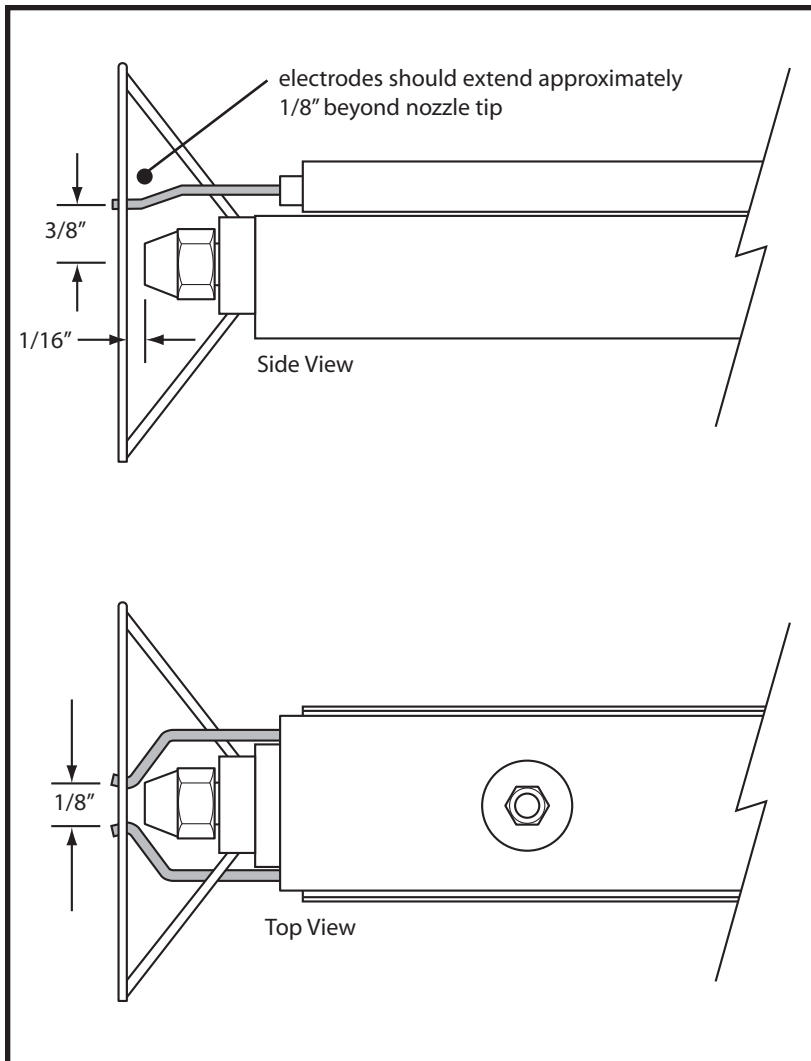

1. Disconnect power to the boiler.
2. Remove the pre-heater assembly from the burner housing. Disassemble and clean all parts as instructed on pages 34-37.
3. Using a 7/16" wrench, carefully remove the one-piece ignitor from the air pre-heater.
4. Install a new one piece ignitor (P/N 3730) to the top of the air pre-heater. **NOTE:** The tips of the ignitor should be 3/8" above the center of the nozzle assembly and should extend approximately 1/8" beyond the end of the nozzle. The tips of the one piece ignitor should be 1/8" apart. Adjust as required and tighten nut on the top of the ignitor (see illustrations for clarification of placement).
5. Re-assemble pre-heater assembly (see pages 34-37) carefully re-install the pre-heater assembly into burner housing. The turbulator should be approximately 1/4" from the end of the burner tube. Adjust as required and secure the pre-heater assembly to the burner housing by tightening the adjustment screw on the side of the burner housing (see illustration).

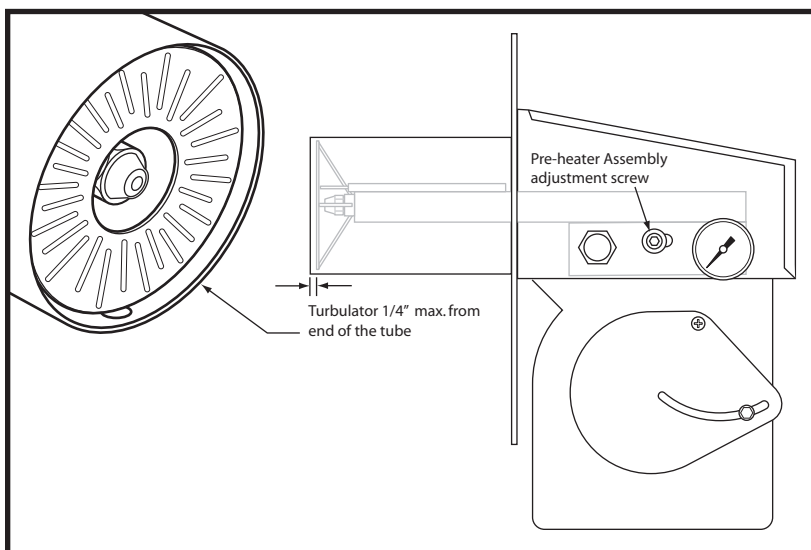

### Air Pre-Heater Diaphragm Replacement

1. Remove the four hex cap screws from the diaphragm assembly and discard.
2. Disassemble and discard diaphragm, spring and o-ring .
3. Thoroughly clean remaining parts.
4. Re-assemble using new diaphragm, o-ring, spring and hex cap screws.

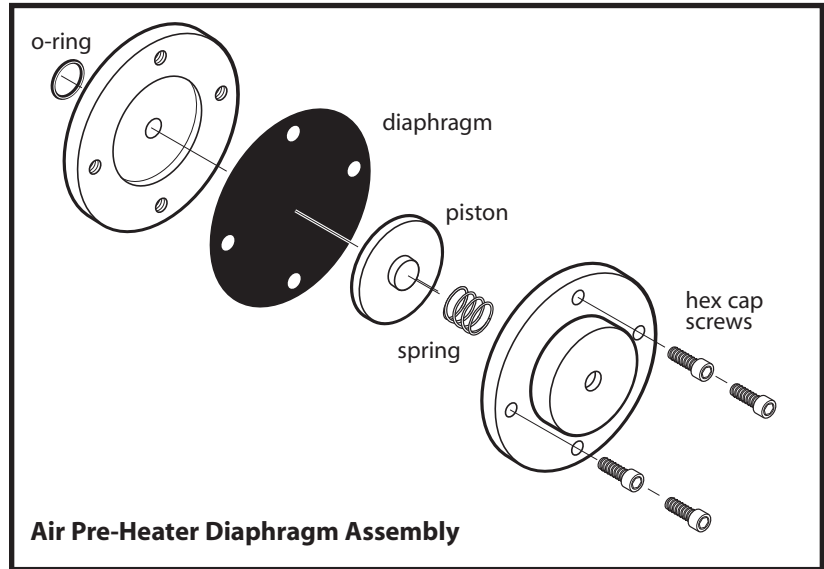

### Air Pre-Heater Nozzle Cleaning / Replacement

1. Periodic cleaning of the nozzle assembly may be required.
2. Carefully remove nozzle from the air pre-heater block.
3. Disassemble the nozzle as shown and clean thoroughly. Re-assemble nozzle.
4. Carefully remove the quad ring from the block and inspect. Replace if necessary.
5. Insert clean/new quad ring into the air pre-heater block. **NOTE:** The quad ring must be properly seated. Failure to properly seat the quad ring may result in leakage and improper burner operation. **DO NOT INSTALL QUAD RING ON THE NOZZLE.**
6. Lubricate pin/seat and re-install nozzle. Tighten securely.

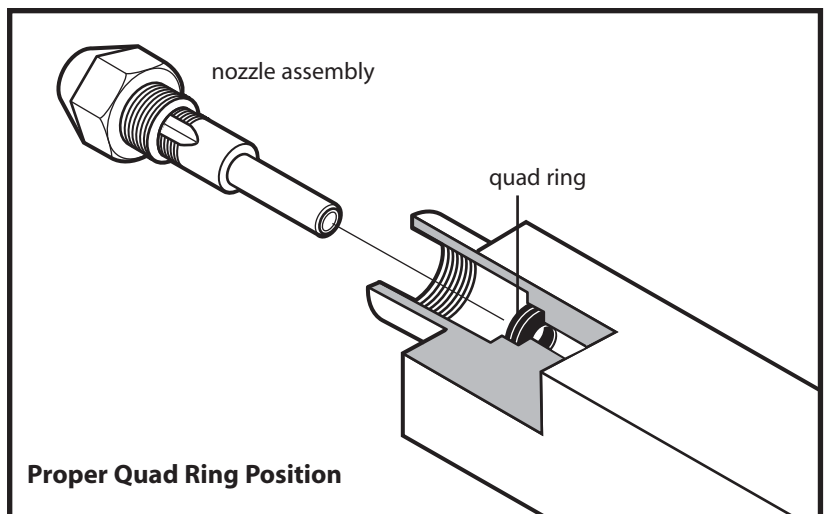
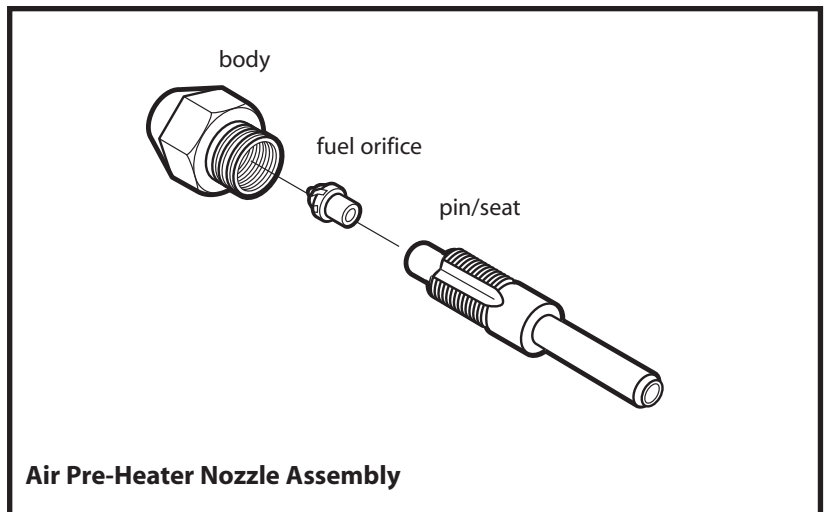

**Failure to properly seat the quad ring may result in leakage and improper burner operation. DO NOT INSTALL QUAD RING ON THE NOZZLE.**





## Section 19 - Troubleshooting

Symptom	Possible Cause	Corrective Action
<b>A. Burner will not start</b>	<ol style="list-style-type: none"> <li>1. Main electrical power circuit breaker tripped</li> <li>2. Service disconnect switch off or fuse blown</li> <li>3. Thermostat turned down/ improperly installed/ defective</li> <li>4. Oil primary safety tripped/defective</li> <li>5. Too much light showing on cad cell/defective</li> </ol>	<ol style="list-style-type: none"> <li>1. Reset breaker</li> <li>2. Turn switch on or replace fuse</li> <li>3. Turn thermostat up, check wires/test components/replace</li> <li>4. Reset/test components, replace if needed</li> <li>5. Eliminate light to cad cell Test component</li> </ol>
<b>B. Burner attempts to fire, but does not establish a flame</b>	<ol style="list-style-type: none"> <li>1. Low oil in supply tank or contaminated fuel</li> <li>2. Plugged or worn nozzle</li> <li>3. Fuel pressure gauge fluctuating/pumping system</li> <li>4. Pre-heater switch is turned off or defective, or defective cartridge heater</li> <li>5. Transformer/electrodes not sparking</li> <li>6. No air pressure/defective regulator/defective solenoid</li> <li>7. Water in air system</li> <li>8. Combustion blower not properly adjusted or defective</li> <li>9. Improper draft</li> <li>10. Plugged heat exchanger, or chimney</li> </ol>	<ol style="list-style-type: none"> <li>1. Fill tank, or drain and clean tank</li> <li>2. Clean or replace</li> <li>3. See section 7, Page 12</li> <li>4. Turn switch on or test switch and cartridge heater</li> <li>5. Test transformer/look for shorts &amp; repair Replace electrodes/ transformer</li> <li>6. Turn compressor on/test regulator/solenoid. Replace defective components</li> <li>7. Clean air pre-heater and drain water from system</li> <li>8. See flame adjustment pages 29-30. Replace blower</li> <li>9. Check draft see page 11. Make sure chimney is properly installed</li> <li>10. Clean heater including manifold, chimney</li> </ol>



## Section 19 - Trouble-Shooting

Symptom	Possible Cause	Corrective Action
<p><b>C. Burner fires, and then fails on oil primary safety</b></p>	<ol style="list-style-type: none"> <li>1. Contaminated fuel supply (water/anti freeze/gear lube) or dirty fuel filter.</li> <li>2. Improper draft</li> <li>3. Plugged heat exchanger, manifold, or chimney</li> <li>4. Wrong air pressure</li> <li>5. Wrong fuel pressure or pressure fluctuating</li> <li>6. Improper combustion blower setting, or blower is defective</li> <li>7. Oil primary/cad cell defective. Cad cell improperly adjusted. Dirty flame turbulator.</li> <li>8. Plugged nozzle or pre-heater assembly</li> </ol>	<ol style="list-style-type: none"> <li>1. Drain and clean fuel supply tank. Clean fuel filter (see page 33)</li> <li>2. Check draft see page 10. Make sure chimney is properly installed</li> <li>3. Clean heater including manifold, and chimney</li> <li>4. See flame adjustment pages 29-30</li> <li>5. See flame adjustment pages 29-30. See fuel piping page 12</li> <li>6. See flame adjustment pages 29-30. See fuel piping page 12</li> <li>7. Test components/adjust cad cell/ clean turbulator</li> <li>8. Clean nozzle and /or pre-heater assembly</li> </ol>
<p><b>D. Pre-heater assembly not heating</b></p>	<ol style="list-style-type: none"> <li>1. Cartridge heaters defective or disconnected</li> <li>2. Snap disc defective</li> <li>3. Hi-Limit snap disc defective</li> </ol>	<ol style="list-style-type: none"> <li>1. Test cartridge heaters at room temperature using an ohm meter . Air heater 112 <math>\Omega</math> <math>\pm</math>10%. Oil heater 37 <math>\Omega</math> <math>\pm</math>10%.</li> <li>2. Test snap switch for continuity if pre-heater is cold</li> <li>3. Replace snap disc assembly</li> </ol>



## **LANAIR 10 YEAR WASTE OIL BOILER LIMITED WARRANTY**

*Lanair Products LLC., MANUFACTURER, hereby warrants that manufacturer's products shall be free from defect in material and workmanship under normal use according to the provisions and limitations herein set forth for a period of one (1) year provided same is returned (pre-paid) F.O.B. Janesville, Wisconsin for inspection and warranty determination.*

*MANUFACTURER warrants the heat exchanger/combustion chamber for three (3) years from the date of purchase and pro rata thereafter according to the following schedule: If a defect occurs during the first three years, MANUFACTURER will repair or replace the combustion chamber / heat exchanger FREE\* of charge. If a defect occurs in years four through ten (4-10) MANUFACTURER will repair or replace your combustion chamber/heat exchanger. Your guaranteed replacement cost will be shared by MANUFACTURER 50/50.*

*IMPORTANT: Combustion chamber / heat exchanger must be maintained in accordance with the installation/operating instructions. This extended warranty does not cover normal wear items such as gasket material, chamber inserts, nuts, bolts, labor costs, etc. The warranty card must be returned within ten (10) days of purchase date in order for this warranty to be valid.*

*\*MANUFACTURER'S determination regarding repair or replacement is final.  
Cost of freight is owner's responsibility.*

*Model Number MXB 250 / 400 Series Boiler*

*Date Purchased: \_\_\_\_\_*

### **Conditions That Will Void Warranty**

- Installation by anyone other than a licensed HVAC/Hydronics Installer
- Use of liquids such as: solvents, brake fluid, gasoline, K-1, kerosene, paint thinners, gear lube, transformer oil, cutting oils, anti-freeze, water or any other liquid not approved for use.
- Tampering with internal components
- Boiler has not been installed or serviced in accordance to the installation / operating manual.
- Alteration or misuse of any part
- Use of parts other than those supplied by Lanair.

**NOTE: Re-stocking fee of 20% applies on all returned parts**

**NOTE: Lanair may require photographs of the heater installation for warranty determination**

### **Items Not Covered Under Warranty**

- A. Any portion of the combustion chamber / heat exchanger if:**
  1. The unit is not installed per the owners manual.
  2. The yearly inspection requirements are not current.
  3. If the boiler is used for a purpose for which it is not intended.
  4. If the boiler is not operated in accordance with the printed instructions in the owners manual.
  5. If any alterations or unauthorized repairs are made to the unit.
  6. Maintenance items including normal wear & tear items.
- B. Damage incurred from abuse, neglect, shipping, natural acts, misuse or accident.**
- C. Labor costs for service calls for any reason including:**
  1. Cleaning or performing required maintenance.
  2. Installation corrections
  3. Any parts installation.
- D. Parts that are replaced because of normal wear and tear.**
- E. Goods purchased under this agreement shall be used exclusively by the buyer and no other person or third party shall benefit from the express or implied warranties contained in the agreement.**

# Section 21 - Burner Reference Diagram

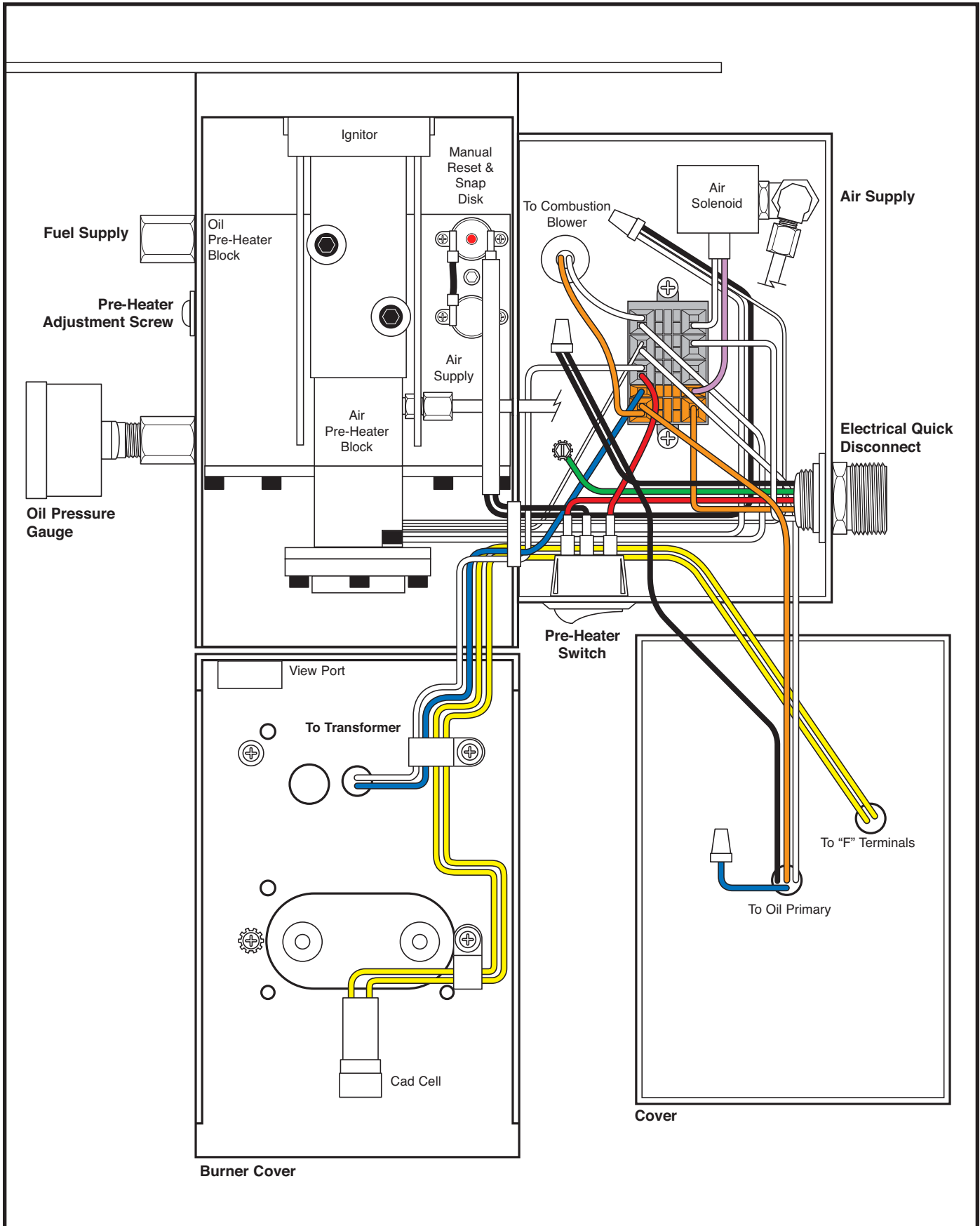



**Lanair Products LLC**  
4109 Capital Circle  
Janesville, Wisconsin 53546  
1-888-370-6531  
[www.lanair.com](http://www.lanair.com)