

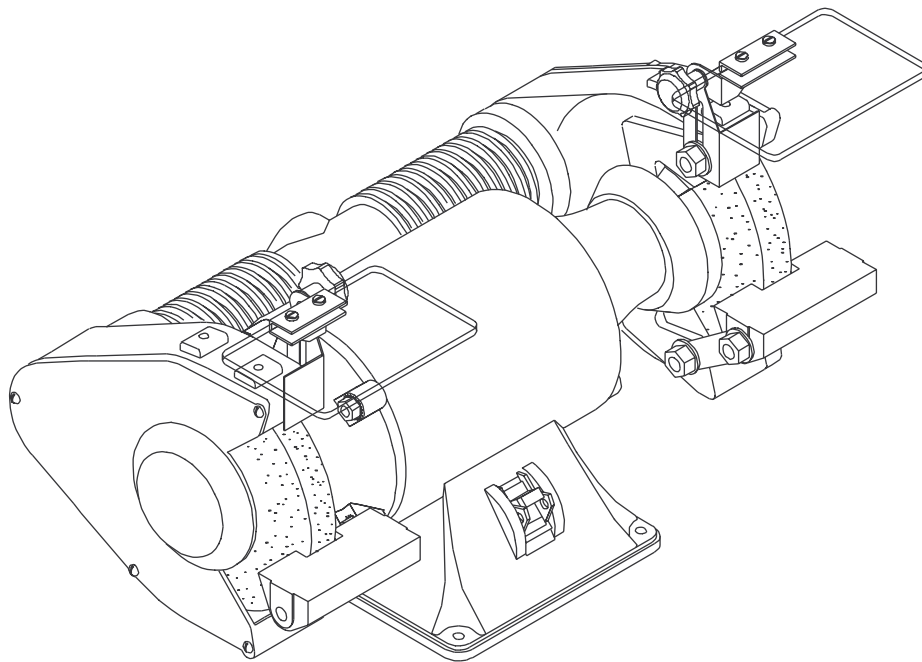

## 6", 7", 8" & 10" BENCH GRINDER



***Read carefully and follow all safety rules and operating instructions before first use of this product.***

**DESCRIPTION**

Palmgren Bench Grinders are equipped with a totally enclosed ball bearing motor. Armature assembly is dynamically balanced for smooth operation. Motor housing is compact so long pieces of work can press against both wheels without touching the motor frame. Removable wheel guards allow for easy changing of wheels. Two-way tool rests are adjustable for wheel wear and angle grinding. Grinders come complete with spark guards, safety eyeshields and dust collection hose. (Dust Collection hose not included with 82061).

**UNPACKING**

Check for shipping damage. If damage has occurred, a claim must be filed with the carrier immediately. Check for completeness. Immediately report missing parts to dealer.

**SPECIFICATIONS**

**82061 & 82062-6" Bench Grinder**

Horsepower .....	1/3
Voltage .....	120/240
Amperes .....	3.5/1.75
Hertz .....	.60
Phase .....	Single
RPM .....	3450
Rotation (viewed from left side) .....	Clockwise
Wheel diameter .....	6"
Wheel bore .....	1/2"

**82071-7" Bench Grinder**

Horsepower .....	1/2
Voltage .....	120/240
Amperes .....	5.0/2.5
Hertz .....	.60
Phase .....	Single
RPM .....	3450
Rotation (viewed from left side) .....	Clockwise
Wheel diameter .....	7"
Wheel bore .....	5/8"

**82081-8" Bench Grinder**

Horsepower .....	3/4
Voltage .....	120/240
Amperes .....	7.0/3.5
Hertz .....	.60
Phase .....	Single
RPM .....	3450
Rotation (viewed from left side) .....	Clockwise
Wheel diameter .....	8"
Wheel bore .....	5/8"

**82101-10" Bench Grinder**

Horsepower .....	1
Voltage .....	120/240
Amperes .....	10.0/5.0
Hertz .....	.60
Phase .....	Single
RPM .....	1725
Rotation (viewed from left side) .....	Clockwise
Wheel diameter .....	10"
Wheel bore .....	1"

**SAFETY RULES**

**WARNING:** For your own safety, read operating instructions manual before operating tool.

**BE PREPARED FOR JOB**

- Wear proper apparel. Do not wear loose clothing, gloves, neckties, rings, bracelets or other jewelry which may get caught in moving parts of machine.
- Wear protective hair covering to contain long hair.
- Wear safety shoes with non-slip soles.
- Wear safety glasses complying with United States ANSI Z87.1. Everyday glasses have only impact resistant lenses. They are NOT safety glasses.
- Wear face mask or dust mask if operation is dusty.
- Be alert and think clearly. Never operate power tools when tired, intoxicated or when taking medications that cause drowsiness.

**PREPARE WORK AREA FOR JOB**

- Keep work area clean. Cluttered work areas and work benches invite accidents.
- Do not use power tools in dangerous environments. Do not use power tools in damp or wet locations. Do not expose power tools to rain.
- Work area should be properly lighted.
- Proper electrical plug should be plugged directly into properly grounded, three-prong receptacle.
- Extension cords should have a grounding prong and the three wires of the extension cord should be of the correct gauge.
- Keep visitors at a safe distance from work area.
- Keep children out of the workplace. Make workshop childproof. Use padlocks, master switches or remove switch keys to prevent any unintentional use of power tools.

**TOOL SHOULD BE MAINTAINED**

- Always unplug tool prior to inspection.
- Consult manual for specific maintaining and adjusting procedures.
- Keep tool clean for safest operation.
- Remove adjusting tools. Form habit of checking to see that adjusting tools are removed before turning machine on.
- Keep all parts in working order. Check to determine that the guard or other parts will operate properly and perform their intended function.
- Check for damaged parts. Check for alignment of moving parts, binding of moving parts, breakage of parts, mounting and any other condition that may affect a tool's operation.
- A guard or other part that is damaged should be properly repaired or replaced. Do not perform makeshift repairs. (Use the parts list to order replacement parts.)

**KNOW HOW TO USE TOOL**

- Use right tool for job. Do not force tool or attachment to do a job for which it was not designed.
- Disconnect tool from power when changing accessories such as grinding wheels, buffing wheels and the like.
- Avoid accidental start-up. Make sure that the switch is in the off position before plugging in.
- Do not force tool. It will work most efficiently at the rate for which it was designed.
- Keep hands away from moving parts and grinding surfaces.

**SAFETY RULES (CONTINUED)**

- Never leave a tool running unattended. Turn the power off and do not leave tool until it comes to a complete stop.
- Do not overreach. Keep proper footing and balance.
- Never stand on tool. Serious injury could occur if tool is tipped over.
- Know your tool. Learn the tool's operation, application and specific limitations.
- Use recommended accessories. Understand and obey all safety instructions supplied with accessories. The use of improper accessories may cause risk of injury to persons.
- Do not over tighten wheel nut. Replace cracked wheel immediately. Use only flanges supplied with the grinder.
- Adjust distance between wheel and tool rest to maintain  $\frac{1}{16}$ " or less gap.
- Handle the workpiece correctly. Whenever possible, use tool rest to support workpiece during grinding operation. Turn tool off if it jams.
- Always use guards and eyeshields.
- Clean grinding dust from beneath tool frequently.

**ASSEMBLY****ASSEMBLY – 82061**

Parts to be fastened to the unit should be located and accounted for (See List and Figure 1).

**IMPORTANT:** Do not attempt assembly if parts are missing. Use this manual to order replacement parts.

- A  $\frac{5}{16}$ "-18 x  $1\frac{1}{2}$ " Carriage bolt, 4 each
- B Spacer, 2 each
- C Tool rest bracket, 4 each
- D  $\frac{5}{16}$ " Flat washer, 4 each
- E  $\frac{5}{16}$ "-18 Hex nut, 2 each
- F Tool rest, 2 each
- G  $\frac{5}{16}$ " Flat washer, 4 each
- H  $\frac{5}{16}$ "-18 Hex nut, 4 each
- I  $\frac{5}{16}$ "-18 x  $1\frac{1}{4}$ " Carriage bolt, 4 each
- J Upright, 2 each
- K Eyeshield, 2 each
- L Lower eyeshield bracket, 2 each
- M Upper eyeshield bracket, 2 each (left and right)
- N #10-24 x  $\frac{3}{8}$ " Pan head screw, 4 each
- O  $\frac{5}{16}$ "-18 Wing nut, 2 each
- P Spark guard, 2 each (not shown)

**NOTE:** Parts marked with an asterisk (\*) are mounted to the grinder at the factory.

**TOOL REST ASSEMBLY**

- Slide  $\frac{5}{16}$ "-18 x  $1\frac{1}{2}$ " carriage bolt (A) into square hole in tool rest bracket (C). Slide spacer (B) onto carriage bolt. Slide carriage bolt with spacer and bracket into hole on inside of tool rest (F) as shown in Figure 1. Slide  $\frac{5}{16}$ " flat washer (G) and  $\frac{5}{16}$ "-18 hex nut (H) onto carriage bolt. Tighten nut finger tight.

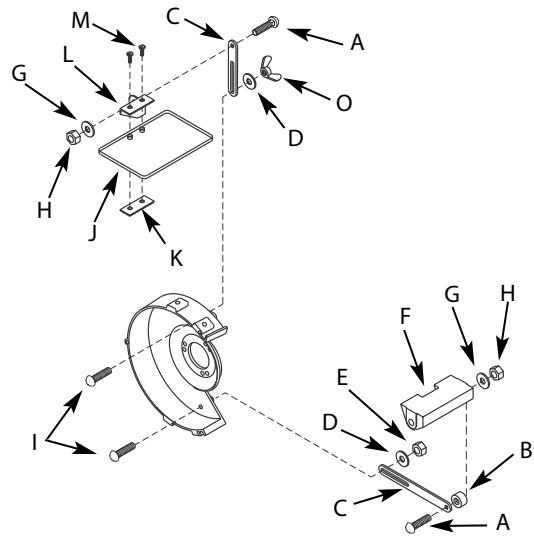

**Figure 1 – Left Tool Rest and Eyeshield Assembly (82061)**

- Remove  $\frac{5}{16}$ " hex nut (O) and flat washer (D) from  $\frac{5}{16}$ "-18 x  $1\frac{1}{4}$ " carriage bolt (I) mounted to bottom front of left wheel guard.
- Slide slot in tool rest bracket over  $\frac{5}{16}$ " bolt. Replace flat washer and hex nut. Position tool rest so that distance between tool rest and grinding wheel is less than  $\frac{1}{16}$ ". Secure all nuts and bolts.
- Mount right tool rest in a similar manner.

**EYESHIELD ASSEMBLY**

- Remove  $\frac{5}{16}$ " wing nut (E) and  $\frac{5}{16}$ " flat washer (D) from  $\frac{5}{16}$ "-18 x  $1\frac{1}{4}$ " carriage bolt (I) mounted to top front of left wheel guard.
- Slide slot in upright (J) over carriage bolt and replace washer and wing nut.
- Remove pan head screws (N) from eyeshield assembly. Mount left upper eyeshield bracket (M) to eyeshield using pan head screws and lower eyeshield bracket.

**NOTE:** Left upper eyeshield bracket is stamped "L" for identification.

- Slide  $\frac{5}{16}$ "-18 x  $1\frac{1}{2}$ " carriage bolt (A) into square in upper bracket from right side. Slide upper eyeshield bracket over carriage bolt and secure with  $\frac{5}{16}$ " flat washer (G) and hex nut (H). Locate eyeshield in desired position for protecting operator and secure all nuts and bolts.
- Mount right eyeshield assembly in a similar manner.

**SPARK GUARDS**

- Spark guards (O) are mounted to the grinder using pan head screws already mounted to wheel guard cover.
- Remove pan head screws at top of wheel guard covers toward front of grinder. Secure spark guards to wheel guard covers using pan head screws. Position spark guard so there is a gap of no more than  $\frac{1}{16}$ " between grinding wheel and the spark guard. Tighten pan head screws securely.

**ASSEMBLY (CONTINUED)****ASSEMBLY - 82062, 82071, 82081 AND 82101**

Parts to be fastened to the unit should be located and accounted for (See List and Figure 2).

**IMPORTANT:** Do not attempt assembly if parts are missing. Use this manual to order replacement parts.

- A  $\frac{5}{16}$ "-18 x  $1\frac{1}{4}$ " Carriage bolt, 2 each
- $\frac{5}{16}$ "-18 x  $1\frac{1}{2}$ " Carriage bolt, 2 each (Model 82062 only)
- B Tool rest bracket, 2 each
- C  $\frac{3}{8}$ " Flat washer, 4 each
- D  $\frac{3}{8}$ "-16 Hex nut, 2 each
- E Tool rest, 2 each
- F  $\frac{5}{16}$ " Flat washer, 2 each
- G  $\frac{5}{16}$ "-18 Hex nut, 2 each
- H  $\frac{3}{8}$ "-16 x  $1\frac{1}{4}$ " Hex bolt, 4 each
- I Knob, 2 each
- J Spark guard, 2 each
- K Eyeshield, 2 each
- L Lower eyeshield bracket, 2 each
- M Upper eyeshield bracket, 2 each (left and right)
- N #10-24 x  $\frac{3}{8}$ " Pan head screw, 4 each
- O 6-1.0 x 12mm Flange screw, 2 each
- P 6mm Flat washer, 2 each
- Q Spacer, 2 each (Model 82062 only)
- R  $\frac{3}{8}$ "-16 Wing nut, 2 each
- S Dust collector hose (not shown)

**NOTE:** Parts marked with an asterisk (\*) are mounted to the grinder at the factory.

**TOOL REST ASSEMBLY**

- Slide  $\frac{5}{16}$ "-18" carriage bolt (A) into square hole in tool rest bracket (B). Slide spacer (Q) onto carriage bolt (Spacer is not needed for models 82071, 82081 and 82101.). Slide carriage bolt with bracket into hole on inside of tool rest (E) as shown in Figure 2. Slide  $\frac{5}{16}$ " flat washer (F) and  $\frac{5}{16}$ "-18 hex nut (G) onto carriage bolt. Tighten nut finger tight.

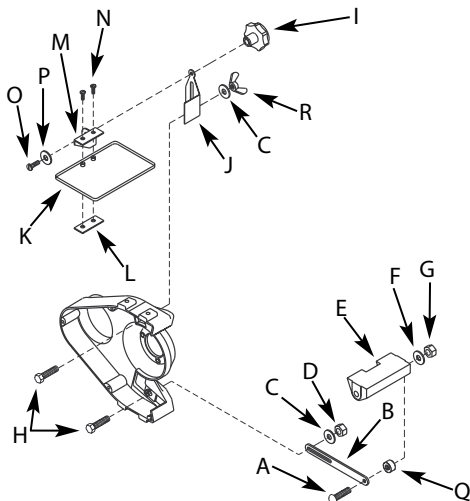

**Figure 2 – Left Tool Rest and Eyeshield Assembly (82062, 82071, 82081 and 82101)**

- Remove  $\frac{3}{8}$ " hex nut (D) and flat washer (C) from  $\frac{3}{8}$ "-16 x  $1\frac{1}{4}$ " hex bolt (H) mounted to bottom front of left wheel guard.
- Slide slot in tool rest bracket over  $\frac{3}{8}$ " bolt. Replace flat washer and hex nut. Position tool rest so that distance between tool rest and grinding wheel is less than  $\frac{1}{16}$ ". Secure all nuts and bolts.

- Mount right tool rest in a similar manner.

**EYESHIELD ASSEMBLY**

- Remove  $\frac{3}{8}$ " wing nut (R) and  $\frac{3}{8}$ " flat washer (C) from  $\frac{3}{8}$ "-16 x  $1\frac{1}{4}$ " hex bolt (H) mounted to top front of left wheel guard.
- Slide slot in spark guard (J) over hex bolt and replace washer and wing nut.
- Remove pan head screws (N) from eyeshield assembly. Mount left upper eyeshield bracket (M) to eyeshield using pan head screws and lower eyeshield bracket.

**NOTE:** Left upper eyeshield bracket is stamped "L" for identification.

- Slide 6-1.0 x 12mm flange screw (O) and 6mm flat washer (P) through left upper eyeshield bracket (M) and through hole at top of left spark guard (J) and secure with knob (I).
- Locate eyeshield in desired position for protecting operator and secure all nuts and bolts.
- Mount right eyeshield assembly in a similar manner.

**DUST COLLECTOR HOSE**

- A dust collector hose has been provided with grinder. Slide hoses onto sides of T-connector and flanges. Mount the hose by sliding the flanges at each end over the exhaust ports on the left and right wheel guards. Attach  $2\frac{1}{2}$ " shop vacuum hose to collector hose. Be sure hose is mounted securely.

**DANGER:** Be sure to empty shop vacuum of all flammable material (flammable liquids and vapors, paper, wood, plastic, etc.) before connecting vacuum to grinder. Hot sparks from grinder may ignite flammable materials in shop vacuum.

**INSTALLATION****MOUNT GRINDER**

- Mount grinder to a solid horizontal surface (hardware not provided). If mounted to metal pedestal, align mounting holes with corresponding holes in pedestal. Insert a  $\frac{1}{4}$ "-20 x  $1\frac{1}{4}$ " hex head bolt with flat washer through base of grinder. From bottom of pedestal, place a  $\frac{1}{4}$ " flat washer and  $\frac{1}{4}$ "-20 hex nut onto the bolt. Tighten only until space between grinder base and pedestal is  $\frac{1}{8}$ " (base should be flush for 82101). Using second nut on each bolt, jam tighten against the first to prevent loosening by vibration.
- To mount grinder to wooden bench top, use  $\frac{1}{4}$  x  $1\frac{1}{4}$ " wood screws with flat washers beneath heads. Tighten screws until space between grinder base and bench top is  $\frac{1}{8}$ " (base should be flush for 82101).

**GROUNDING INSTRUCTIONS**

**WARNING:** Improper connection of equipment grounding conductor can result in the risk of electrical shock. Equipment should be grounded while in use to protect operator from electrical shock.

- Check with a qualified electrician if grounding instructions are not understood or if in doubt as to whether the tool is properly grounded.
- This grinder is equipped with an approved 3-conductor cord rated at 300V and a 3-prong, grounding type plug (See Figure 3) for your protection against shock hazards.

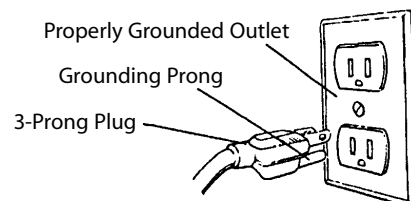

**Figure 3 – 3-Prong Receptacle**

**INSTALLATION (CONTINUED)**

- Grounding plug should be plugged directly into a properly installed and grounded 3-prong grounding-type receptacle (See Figure 3).
- Do not remove or alter grounding prong in any manner. In the event of a malfunction or breakdown, grounding provides a path of least resistance for electrical shock.

**WARNING:** Do not permit fingers to touch the terminals of plug when installing or removing from outlet.

- Plug must be plugged into matching outlet that is properly installed and grounded in accordance with all local codes and ordinances. Do not modify plug provided. If it will not fit in outlet, have proper outlet installed by a qualified electrician.
- Inspect tool cords periodically, and, if damaged, have repaired by an authorized service facility.
- Green (or green and yellow) conductor in cord is the grounding wire. If repair or replacement of the electric cord or plug is necessary, do not connect the green (or green and yellow) wire to a live terminal.
- Where a 2-prong wall receptacle is encountered, it must be replaced with a properly grounded 3-prong receptacle installed in accordance with National Electric Code and local codes and ordinances.

**WARNING:** This work should be performed by a qualified electrician.

- A temporary 3-prong to 2-prong grounding adapter (See Figure 4) is available for connecting plugs to a two pole outlet if it is properly grounded.

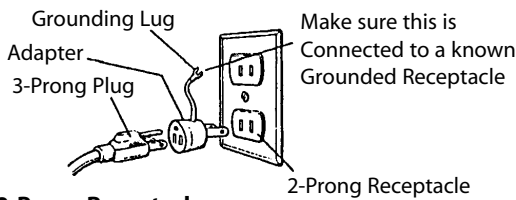

**Figure 4 – 2-Prong Receptacle**

- Do not use a 3-prong to 2-prong grounding adapter unless permitted by local and national codes and ordinances. (A 3-prong to 2-prong grounding adapter is not permitted in Canada.) Where permitted, the rigid green tab or terminal on the side of the adapter must be securely connected to a permanent electrical ground such as a properly grounded water pipe, a properly grounded outlet box or a properly grounded wire system.
- Many cover plate screws, water pipes and outlet boxes are not properly grounded. To ensure proper ground, grounding means must be tested by a qualified electrician.

**EXTENSION CORDS**

- The use of any extension cord will cause some drop in voltage and loss of power.
- Wires of the extension cord must be of sufficient size to carry the current and maintain adequate voltage.
- Running the unit on voltages which are not within  $\pm 10\%$  of the specified voltage may cause overheating and motor burn-out.
- Use the table to determine the minimum wire size (A.W.G.) extension cord.
- Use only 3-wire extension cords having 3-prong grounding type plugs and 3-pole receptacles which accept the tool plug.
- If the extension cord is worn, cut or damaged in any way, replace it immediately.

**EXTENSION CORD LENGTH for Models 82061, 82062, 82071 and 82081**

Wire Size .....	A.W.G.
Up to 25 ft. ....	18

**NOTE:** Using extension cords over 25 ft. long is not recommended.

**EXTENSION CORD LENGTH for Model 82101**

Wire Size .....	A.W.G.
Up to 25 ft. ....	16

**NOTE:** Using extension cords over 25 ft. long is not recommended.

**ELECTRICAL CONNECTIONS**

**WARNING:** All electrical connections must be performed by a qualified electrician. Make sure tool is off and disconnected from power source while motor is mounted, connected, reconnected or anytime wiring is inspected.

- Motor and wires are installed as shown in wiring diagram (See Figure 5). Motor is assembled with approved, 3-conductor cord to be used at 120/240 volts. Motor is prewired at the factory for 120 volts.
- To use the grinder with a 240V power supply, have a qualified electrician rewire motor and attach a 240 volt, 15A three-prong plug onto grinder line cord.

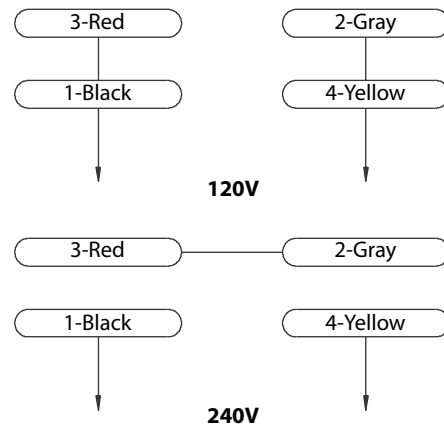

**Figure 5 – Wiring Diagram**

**OPERATION**

**WARNING:** Always wear safety glasses complying with United States ANSI Z87.1 (shown on package) before commencing power tool operation.

- Keep a steady, moderate pressure on the work and keep it moving at an even pace for smooth grinding.
- Pressing too hard overheats the motor and prematurely wears down the grinding wheels.
- Note the original bevel angle on the item to be sharpened and try to maintain that angle. Sharpening a cutting edge requires removing burrs from edge.
- Deburring edge is done best by using the grinder to pull burr from edge across the bevel angle.
- The grinding wheel should rotate into object being sharpened.
- Dip work into a coolant regularly to prevent overheating. Overheating can weaken metals.

**MAINTENANCE**

- As wheels wear, tool rests should be positioned closer to the face of the wheels.
- The gap between the wheel and the tool rest should not be greater than  $\frac{1}{16}$ ". When the wheels are worn to the extent that the  $\frac{1}{16}$ " maximum gap cannot be maintained, the wheels should be replaced.
- Models 82061, 82062, 82071 and 82081: Replacement wheels should have a minimum rated speed of at least 3600 RPM.
- Model 82101: Replacement wheels must have a minimum rated speed of 1800 RPM.
- Maximum wheel diameter is 6" for 82061 and 82062, 7" for 82071, 8" for 82081, and 10" for 82101.
- To loosen nuts holding the wheels, disconnect power and push a wood wedge between the tool rest and the wheel to keep the shaft from turning. The threads on the right side of the grinder (facing unit) are right hand; threads on the left side are left hand. Tighten nuts securely before operating the grinder.
- For grinding efficiency, wheels should be dressed periodically, especially if they become clogged from grinding soft metals.

## TROUBLESHOOTING

SYMPTOM	POSSIBLE CAUSE(S)	CORRECTIVE ACTION
Grinder won't start	<ol style="list-style-type: none"> <li>1. Blown line fuse or tripped circuit breaker</li> <li>2. Low line voltage</li> <li>3. Material wedged between wheel and guard</li> <li>4. Defective switch</li> <li>5. Defective, blown capacitor</li> </ol>	<ol style="list-style-type: none"> <li>1. If fuse is blown, replace with fuse of proper size. If breaker tripped, reset it</li> <li>2. Check power supply for voltage and correct as needed</li> <li>3. Turn grinder off and remove material</li> <li>4. Replace switch</li> <li>5. Replace capacitor</li> </ol>
Excessive vibration	<ol style="list-style-type: none"> <li>1. Improper mounting of grinder or accessories</li> <li>2. Grinding wheel out of balance</li> <li>3. Improper wheel mounting</li> </ol>	<ol style="list-style-type: none"> <li>1. Remount</li> <li>2. Dress wheels or replace wheels</li> <li>3. Remount wheels, but rotate one wheel 90° with respect to its previous position. Other wheel should remain in its original position</li> </ol>
Motor overheating	<ol style="list-style-type: none"> <li>1. Excess pressure required to grind material</li> <li>2. Grinding on side of wheel</li> <li>3. Motor not turning freely (without power)</li> </ol>	<ol style="list-style-type: none"> <li>1. Dress wheel or replace wheel with one of proper grit</li> <li>2. Grind only on face of wheel</li> <li>3. Clean around wheels and shaft and/or replace bearings</li> </ol>
Fuses are being blown or circuit breakers are being tripped	<ol style="list-style-type: none"> <li>1. Overloading due to binding</li> <li>2. Defective plug</li> <li>3. Defective cord</li> <li>4. Defective switch</li> <li>5. Motor wired for different line voltage</li> <li>6. Faulty internal wiring</li> </ol>	<ol style="list-style-type: none"> <li>1. Clean around wheels and shaft and/or replace bearings</li> <li>2. Replace plug</li> <li>3. Replace cord</li> <li>4. Replace switch</li> <li>5. Rewire motor as per wiring diagram, (See Installation, Page 5)</li> <li>6. Contact your Palmgren distributor</li> </ol>
Motor does not develop proper torque	<ol style="list-style-type: none"> <li>1. Motor wired for different line voltage</li> </ol>	<ol style="list-style-type: none"> <li>1. Rewire motor as per wiring diagram, (See Installation, Page 5)</li> </ol>

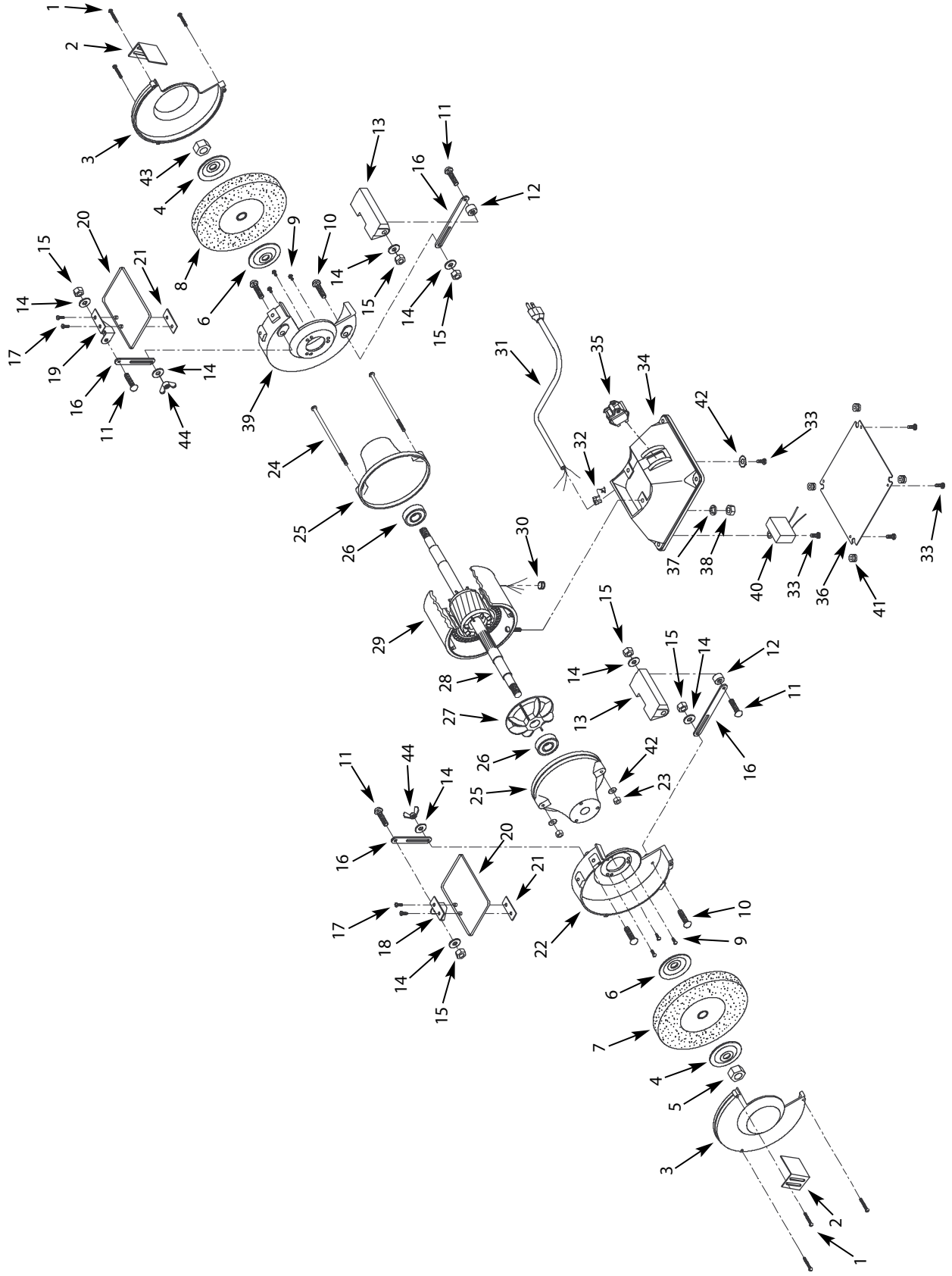

Figure 6 - Replacement Parts Illustration for 6" Bench Grinder



## REPLACEMENT PARTS LIST FOR 6" BENCH GRINDER

Ref. No.	Description	Part Number	Qty.	Ref. No.	Description	Part Number	Qty.
1	1/4"-20 x 7/8" Pan head screw	*	6	25	Endshield	16617.09	2
2	Spark guard	04023.01	2	26	Bearing 6202Z	01540.00	2
3	Wheel guard cover	16900.09	2	27	Motor fan	01608.00	1
4	Flange	18904.00	2	28	Armature	16903.00	1
5	1/2"-12 Hex nut (LH thread)	00064.00	1	29	Stator with housing	16905.09	1
6	Inner wheel flange	17315.00	2	30	Grommet	01066.00	1
7	Grinding wheel (36 coarse grit)	02034.00	1	31	Line cord	00067.00	1
8	Grinding wheel (60 med. grit)	02033.00	1	32	Strain relief	04055.00	1
9	1/4"-20 x 3/8" Flange screw	*	6	33	#10-24 x 1/4" Flange screw	*	6
10	5/16"-18 x 1 1/4" Carriage bolt	*	4	34	Base	16906.09	1
11	5/16"-18 x 1 1/2" Carriage bolt	*	4	35	Rocker switch with key	08066.00	1
12	Spacer	04028.00	2	36	Cover	16909.00	1
13	Tool rest	04030.00	2	37	1/4" Lock washer	*	2
14	5/16" Flat washer	*	8	38	1/4"-20 Hex nut	*	2
15	5/16"-18 Hex nut	*	6	39	Wheel guard (right)	16907.09	1
16	Upright	04029.00	4	40	Capacitor	16908.00	1
17	#10-24 x 3/8" Pan head screw	*	4	41	Bumper	21388.00	4
18	Upper eyeshield bracket (left)	00284.01	1	42	#10 Serrated washer	*	3
19	Upper eyeshield bracket (right)	00282.01	1	43	1/2"-12 Hex nut (RH thread)	00548.00	1
20	Eyeshield	00281.00	2	44	5/16"-18 Wing nut	*	2
21	Lower eyeshield bracket	00280.00	2	Δ	Operators manual	16712.19	1
22	Wheel guard (left)	16901.09	1	<b>Recommended Accessories</b>			
23	5mm-0.8 Hex nut	*	2	Δ	Cast iron tool stand	70101	1
24	5-0.8 x 200mm Pan head screw	04040.00	2				

Δ Not Shown.

\* Standard hardware item available locally.

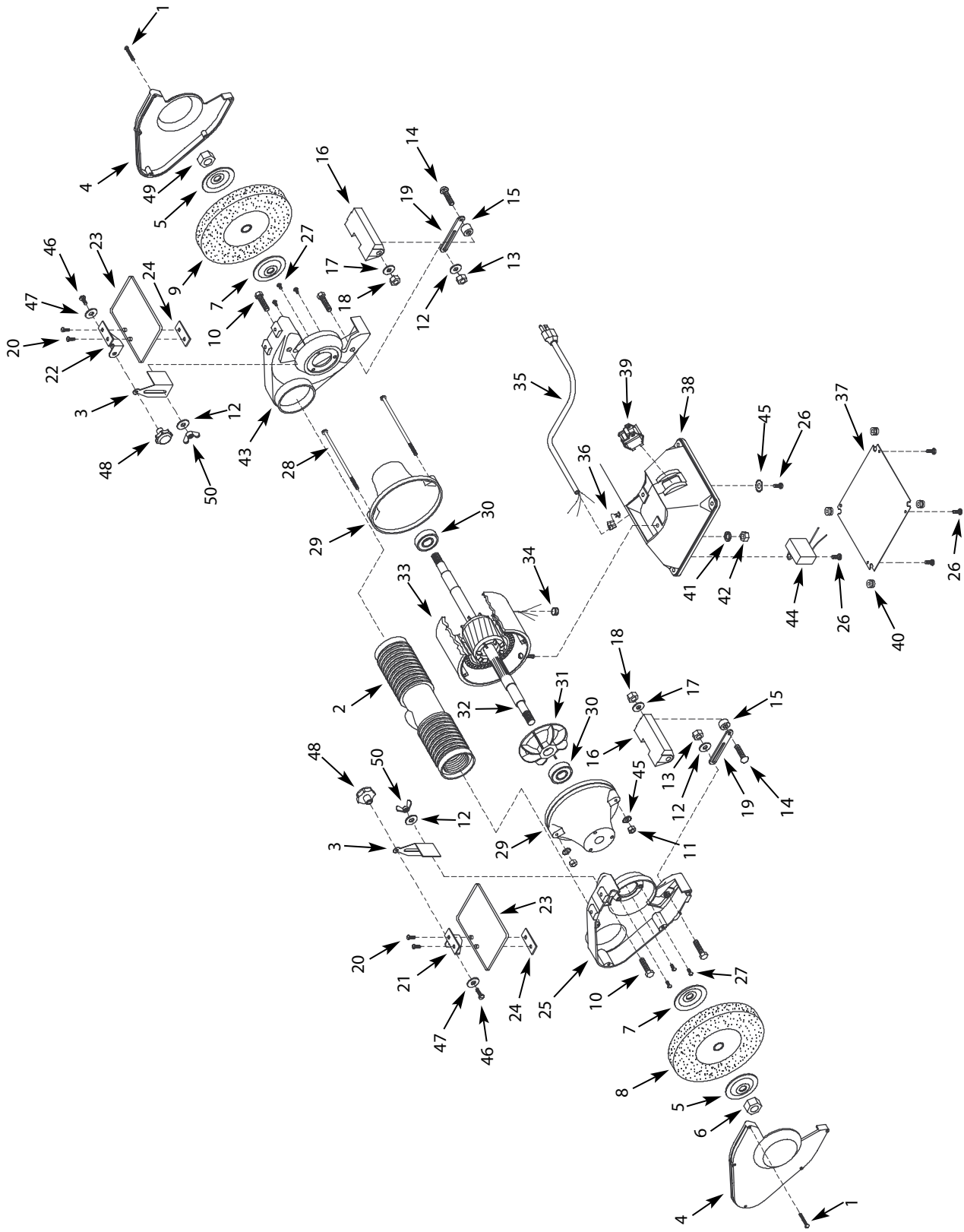

Figure 7 - Replacement Parts Illustration for 6" Bench Grinder

## REPLACEMENT PARTS LIST FOR 6" BENCH GRINDER

Ref. No.	Description	Part Number	Qty.	Ref. No.	Description	Part Number	Qty.
1	#10-24 x 7/8" Pan head screw	*	10	28	5-0.8 x 200mm Pan head screw	04040.00	2
2	Dust collector hose	08070.01	1	29	Endshield	16617.09	2
3	Spark guard (Set of 2)	16841.00	1	30	Bearing 6202ZZ	01540.00	2
4	Wheel guard cover	16615.09	2	31	Motor fan	01608.00	1
5	Flange	18904.00	2	32	Armature	16618.01	1
6	1/2"-12 Hex nut (LH thread)	00064.00	1	33	Stator with housing	16905.09	1
7	Inner wheel flange	17316.00	2	34	Grommet	01066.00	1
8	Grinding wheel (36 coarse grit)	02034.00	1	35	Line cord	00067.00	1
9	Grinding wheel (60 med. grit)	02033.00	1	36	Strain relief	04055.00	1
10	3/8"-16 x 1 1/4" Hex head bolt	*	4	37	Base cover	16909.00	1
11	5-0.8mm Hex nut	*	2	38	Base	16906.09	1
12	3/8" Flat washer	*	4	39	Switch with key	08066.00	1
13	3/8"-16 Hex nut	*	2	40	Base bumper	04051.00	4
14	5/16"-18 x 1 1/2" Carriage bolt	*	2	41	1/4" Lock washer	*	2
15	Spacer	4028.00	2	42	1/4"-20 Hex nut	*	2
16	Tool rest	04030.00	2	43	Wheel guard (right)	16845.09	1
17	5/16" Flat washer	*	2	44	Capacitor	16908.00	1
18	5/16"-18 Hex nut	*	2	45	#10 Serrated washer	*	3
19	Upright	04029.00	2	46	6-1.0 x 12mm Flange screw	16668.00	2
20	#10-24 x 3/8" Pan head screw	*	4	47	6mm Flat washer	*	2
21	Upper eyeshield bracket (left)	00284.01	1	48	Knob	16714.00	2
22	Upper eyeshield bracket (right)	00282.01	1	49	1/2"-12 Hex nut (RH thread)	00548.00	1
23	Eyeshield	00281.00	2	50	3/8"-16 Wing nut	*	2
24	Lower eyeshield bracket	00280.00	2	Δ	Operators manual	16712.19	1
25	Wheel guard (left)	16616.09	1	<b>Recommended Accessories</b>			
26	#10-24 x 1/4" Flange screw	3210.00	6	Δ	Cast iron tool stand	70101	1
27	1/4"-20 x 3/8" Flange screw	16670.00	6				

Δ Not Shown.

\* Standard hardware item available locally.

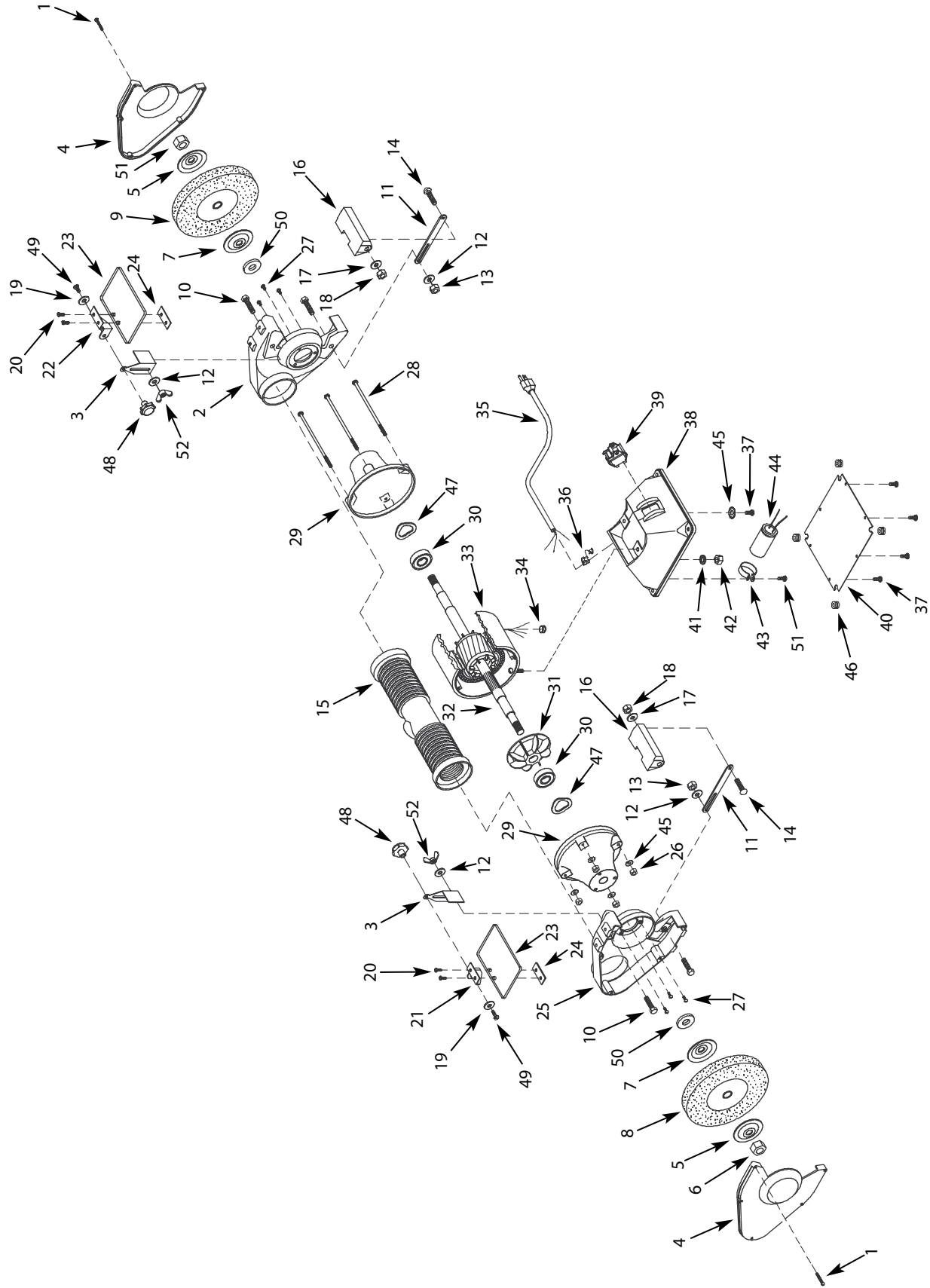

Figure 8 - Replacement Parts Illustration for 7" and 8" Bench Grinders

**REPLACEMENT PARTS LIST FOR 7" AND 8" BENCH GRINDER**

Ref. No.	Description	Part No. For:		Ref. No.	Description	Qty.	Part No. For:		Qty.
		82071	82081				82071	82081	
1	#10-24 x 7/16" Pan head screw	*	*	29	Endshield	10	16627.09	16627.09	2
2	Wheel guard (right)	16840.09	16849.09	30	Bearing 6204ZZ	1	00989.00	00989.00	2
3	Spark guard (Set of 2)	16910.00	16910.00	31	Motor fan	1	01620.00	22041.00	1
4	Wheel guard cover	16637.09	16625.09	32	Armature	2	16702.01	21153.00	1
5	Flange	18905.00	18905.00	33	Stator with housing	2	16703.09	16701.09	1
6	5/8"-11 Hex nut (LH thread)	00088.00	00088.00	34	Grommet	1	01066.00	01066.00	1
7	Inner wheel flange	17317.00	17317.00	35	Line cord	2	00067.00	00090.00	1
8	Grinding wheel (36 coarse grit)	02036.00	02038.00	36	Strain relief	1	04055.00	04055.00	1
9	Grinding wheel (60 med. grit)	02035.00	02037.00	37	#10-24 x 1/4" Flange screw	1	03210.00	03210.00	7
10	3/8"-16 x 1 1/4" Hex head bolt	*	*	38	Base	4	16631.09	16631.09	1
11	Tool rest bracket	08059.00	08059.00	39	Switch with key	2	08066.00	08066.00	1
12	3/8" Flat washer	*	*	40	Base cover	4	16919.00	16919.00	1
13	3/8"-16 Hex nut	*	*	41	1/4" Lock washer	2	*	*	2
14	5/16"-18 x 1 1/4" Carriage bolt	*	*	42	1/4"-20 Hex nut	2	*	*	2
15	Dust collector hose	08070.00	08070.00	43	Capacitor clamp	1	16655.00	16655.00	1
16	Tool rest	08061.01	08061.01	44	Capacitor	2	16646.00	16646.00	1
17	5/16" Flat washer	*	*	45	#10 Serrated washer	2	*	*	5
18	5/16"-18 Hex nut	*	*	46	Base bumper	2	21388.00	21388.00	4
19	6mm Flat washer	*	*	47	Wavy washer	2	16640.00	16440.00	2
20	#10-24 x 3/8" Pan head screw	*	*	48	Knob	4	16714.00	16714.00	2
21	Upper eyeshield bracket (left)	00284.01	00284.01	49	6-1.0 x 12mm Flange screw	1	16668.00	16668.00	2
22	Upper eyeshield bracket (right)	00282.01	00282.01	50	#10-24 x 3/8" Flange screw	1	03207.00	03207.00	1
23	Eyeshield	00281.00	00281.00	51	5/8"-11 Hex nut (RH thread)	2	00087.00	00087.00	1
24	Lower eyeshield bracket	00280.00	00280.00	52	3/8"-16 Wing nut	2	*	*	2
25	Wheel guard (left)	16641.09	16630.09	Δ	Operators manual	1	16712.19	16712.19	1
26	5-0.8 mm Hex nut	*	*	<b>Recommended Accessories</b>					
27	1/4-20 x 1/2" Flange screw	16709.00	16709.00	Δ	Cast iron tool stand	6	70101	70101	1
28	5-0.8 x 228mm Flange screw	16654.00	16654.00			4			

Δ Not Shown.

\* Standard hardware item available locally.

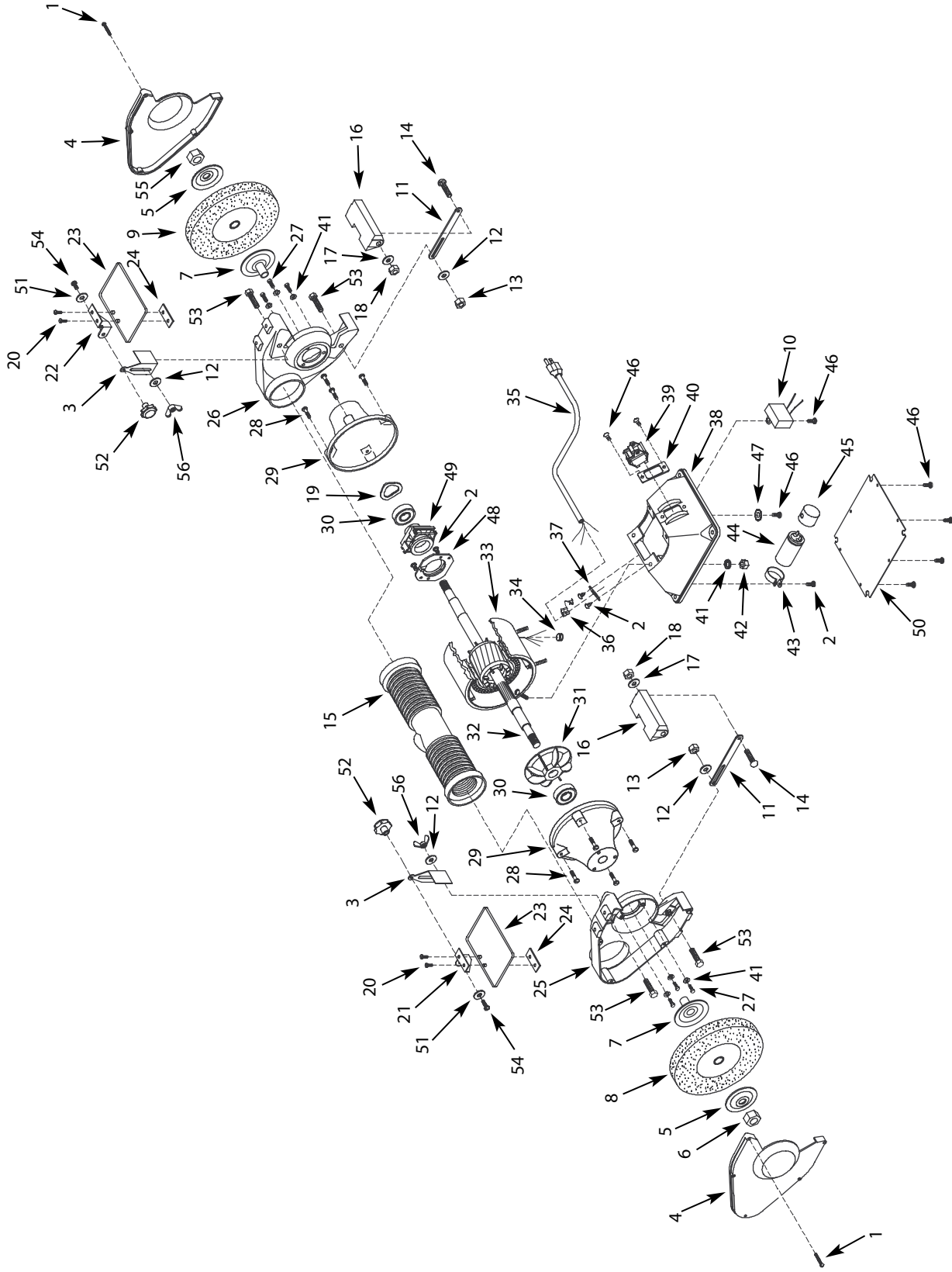

Figure 9 - Replacement Parts Illustration for 10" Bench Grinder

## REPLACEMENT PARTS LIST FOR 10" BENCH GRINDER

Ref. No.	Description	Part Number	Qty.	Ref. No.	Description	Part Number	Qty.
1	1/4-20 x 3/4" Pan head screw	*	10	31	Motor fan	01639.00	1
2	#10-24 x 3/8" Flange screw	03207.00	3	32	Armature	16914.01	1
3	Spark guard (Set of 2)	16910.00	1	33	Stator with housing	16915.09	1
4	Wheel guard cover	16911.09	2	34	Grommet	16916.00	2
5	Flange	18978.00	2	35	Line cord	00090.00	1
6	1"-8 Hex nut (LH thread)	00111.00	1	36	Strain relief	01601.00	1
7	Inner wheel flange	17318.00	2	37	Strain relief plate	08172.00	1
8	Grinding wheel (36 coarse grit)	02040.00	1	38	Base	16917.09	1
9	Grinding wheel (60 med. grit)	02039.00	1	39	Switch with key	08066.00	1
10	Capacitor	16895.00	1	40	Switch plate	08173.00	1
11	Tool rest bracket	08059.00	2	41	5/16" Lock washer	*	10
12	3/8" Flat washer	*	4	42	5/16"-18 Hex nut	*	4
13	3/8"-16 Hex nut	*	2	43	Capacitor clamp	16918.00	1
14	5/16"-18 x 1 1/4" Carriage bolt	*	2	44	Capacitor	08174.00	1
15	Dust collector hose	08070.02	1	45	Capacitor cap	01638.00	2
16	Tool rest	08061.01	2	46	#10-24 x 1/4" Flange screw	03210.00	10
17	5/16" Flat washer	*	2	47	#10 Serrated washer	*	1
18	5/16"-18 Hex nut	*	2	48	Stationary switch	08175.00	1
19	Wavy washer	16620.00	1	49	Rotating switch	00299.00	1
20	#10-24 x 3/8" Pan head screw	*	4	50	Base cover	16919.00	1
21	Upper eyeshield bracket (left)	00284.01	1	51	6mm 3" Flat washer	*	2
22	Upper eyeshield bracket (right)	00282.01	1	52	Knob	16714.00	2
23	Eyeshield	00281.00	2	53	3/8-16 x 1 1/4" Hex head bolt	*	4
24	Lower eyeshield bracket	00280.00	2	54	6-1.0 x 12mm Flange screw	16668.00	2
25	Wheel guard (left)	16912.09	1	55	1"-8 Hex nut (RH thread)	00110.00	1
26	Wheel guard (right)	16715.09	1	56	3/8"-16 Wing nut	*	2
27	5/16"-18 x 5/8" Hex head bolt	*	6	Δ	Operators manual	16712.19	1
28	1/4-20 x 2" Flange screw	03209.00	8		<b>Recommended Accessories</b>		
29	Endshield	16913.09	2	Δ	Cast iron tool stand	70101	1
30	Bearing 6206ZZ	00297.00	2				

Δ Not Shown.

\* Standard hardware item available locally.

**WARRANTY****FULL TWO YEAR WARRANTY ON PALMGREN BENCH GRINDER**

If within two full years from the date of purchase, this Palmgren Bench Grinder fails due to a defect in material or workmanship, Palmgren will repair it free of charge.

To order parts for a non-warranty repair, please contact your preferred Palmgren distributor. To obtain the names of Palmgren distributors or to arrange warranty return, please call Palmgren Steel Products directly at (800) 621-6145.

This warranty gives you specific legal rights and you may have other rights which vary from state to state.

Palmgren Steel Products, Inc., 914 N. Kilbourn Avenue, Chicago, IL 60651-3426

