

TOOLS REQUIRED*

- | | |
|--------------------------------|---------------------------------|
| Pliers | Wire Cutter / Wire Stripper |
| Needle Nose Pliers | (2x) 13mm wrench and/or socket |
| Phillips head screw driver | (2x) 9/16" wrench and/or socket |
| (2x) 1/2" wrench and/or socket | 5/32" allen key |
| 5/16" wrench and/or socket | (2x) 10mm wrench and/or socket |

As illustrated below, this kit consists of:



- | | | |
|-------------------------|-------------------------------------|-------------------------------------|
| (4) M8 x 1.25 x 20 bolt | (4) M8 x 1.25 x 35 bolt | (2) M8 x 1.25 x 20 bolt |
| (4) M8 slit lock washer | (4) M8 slit lock washer | (2) M8 slit lock washer |
| (4) M8 flat washer | (4) M8 flat washer | (2) M8 flat washer |
| | (4) M8 x 1.25 nylon insert lock nut | (2) M8 x 1.25 nylon insert lock nut |

Zip ties not shown

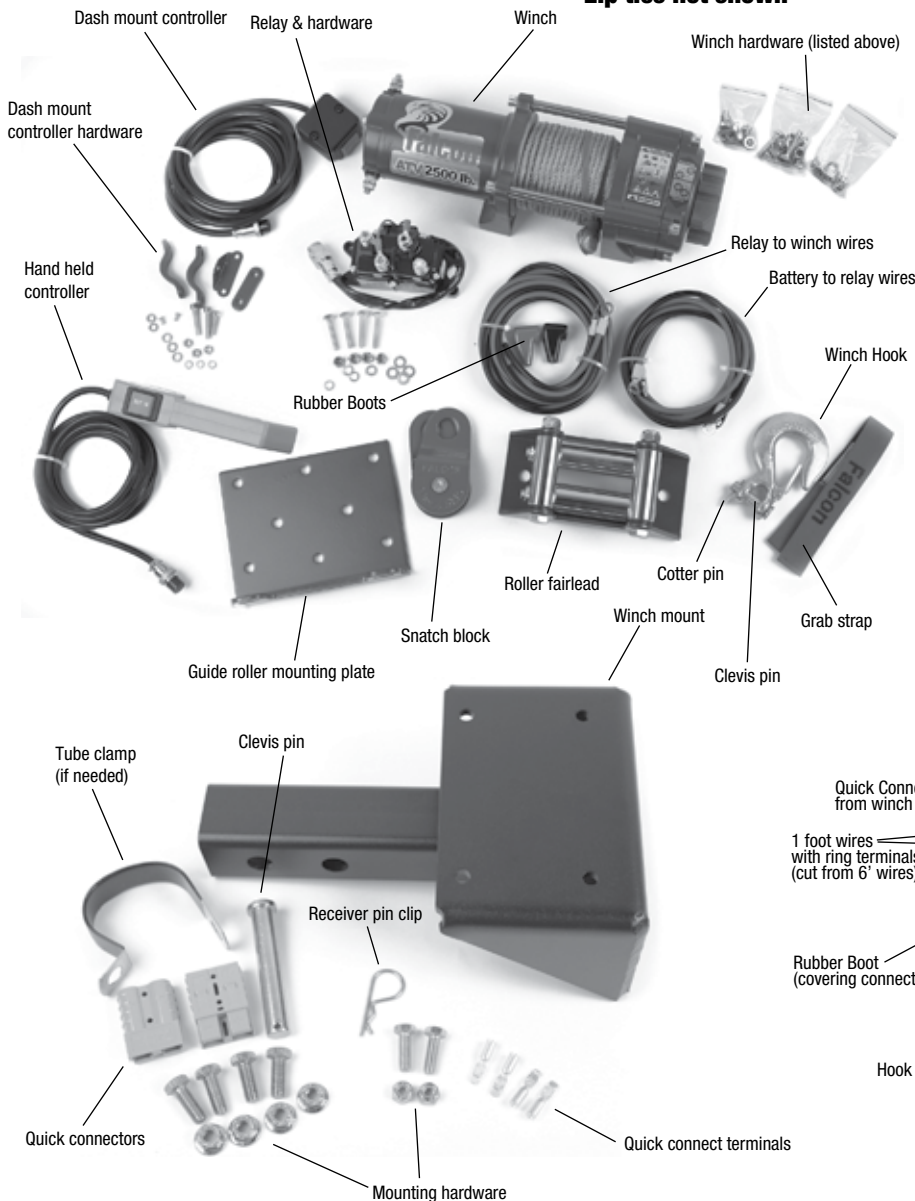

2500 Lb. WINCH KIT (2-55075)

This kit is **ONLY** used on full size UTVs and requires a 2" front receiver hitch

Winch & Fairlead Installation Instructions

Procedure:

- 1 Install the roller fairlead to the mounting plate using the two M8 x 20 cap screws, flat washers, locking washers and M8 hex flange nuts included with the winch. You can tighten these bolts down.
- 2 Put the mounting plate onto the winch mount and then the winch on top of the mounting plate.
- 3 Bolt the winch and mounting plate down to the winch mount using the four M8 x 15 cap screws, lock washers and flat washers. These bolts thread directly into the bottom of the winch. Tighten these bolts.
- 4 Put the winch mount into the 2" front receiver and align the holes. Insert the 5/8" clevis pin and secure with the clevis pin clip.
- 5 Once the winch is secured on the receiver and the receiver is secured in the 2" front receiver you can install the winch hook.
- 6 Using needle nose pliers, remove the cotter pin from the clevis pin in the hook and then remove the clevis pin from the hook.
- 7 Make sure the clutch knob is in the "ON" position and remove the rubber band holding the cable in place. **Keep tension on the cable or else it will unravel off of the winch drum.**
- 8 Carefully turn the clutch knob to the "OFF" position and feed the cable through the roller fairlead and out away from the winch a foot or two. Then turn the knob back to the "ON" position. **Once you have the cable out a couple of feet it should not unravel off of the drum but be cautious.**
- 9 Put the hook over the loop in the cable then insert the clevis pin into the hook and through the loop in the cable. Then put the cotter pin back into the clevis pin.
- 10 Once the winch is wired, you can reel the cable back in.

Installed Winch

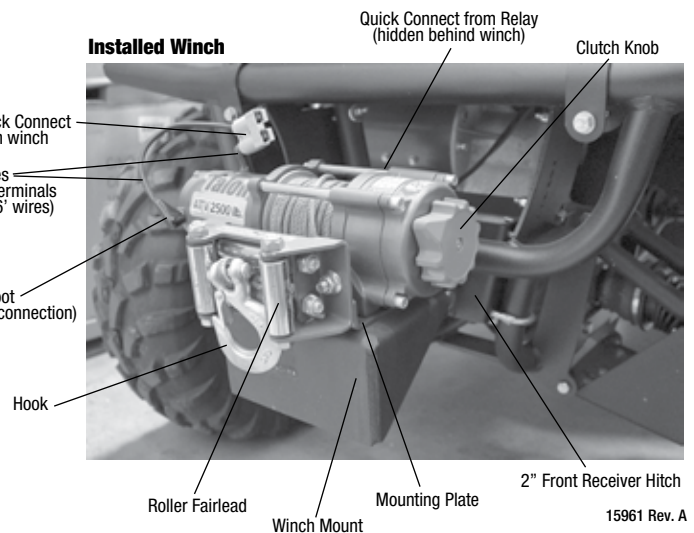

Winch Wiring Instructions

Procedure:

- 1 Choose a mounting location for the relay. Consider the following points for making this choice:
 - a. The relay should be located in a protected area that will not interfere with the normal operation of the UTV.
 - b. You will need to run wires from the relay to the winch, battery and controller location.
 - c. You will need to access the connections on the relay during installation.
 - d. The relay needs to be mounted securely enough to stay in place during UTV operation.
- 2 Attach the 4 ft. red #10 wire to the terminal stud on the relay marked "**Battery +**". Attach the 4 ft. black #10 wire to the terminal stud on the relay marked "**Battery -**".
- 3 Mount the relay in the location you chose in step 1 and route the red & black wires to the UTV battery (see figure 4 for an optimal relay location).
 - a. These wires must be well clear of any moving parts of the UTV.
 - b. Do not allow the wires to come in contact with any hot parts of the UTV such as the exhaust or cylinder head.
- 4 Take both 6 ft. wires and cut off one end of each, 1 ft. from the ring terminal. These 1 ft. sections become the Quick Connect from the winch.
- 5 Strip all four bare ends and then crimp onto the terminals included with the quick connects.
- 6 Put the short end of the red wire into the positive slot in one of the quick connects and put the short end of the black wire into the negative slot of the same quick connect. Then do the same for both long ends of the wires (as shown in figure 2).
- 7 Put the red rubber boot included with the winch on the 1 ft. red #10 wire and connect this to the positive post on the winch motor and tighten.
- 8 Put the black rubber boot included with the winch on the 1 ft. black #10 wire and connect this to the negative post on the winch motor and tighten.
- 9 Route the 5 ft. wires to the relay. Zip ties are included to secure the wire (the tube clamp included with this kit may also be used if needed). When routing these leads to the relay keep the following points in mind:
 - a. These wires must be well clear of any moving parts of the UTV.
 - b. Do not allow the wires to come in contact with any hot parts of the UTV such as the exhaust or cylinder head.
- 10 Attach the 5 ft. red wire to the terminal stud on the relay marked "**Motor +**".
- 11 Attach the 5 ft. black wire to the terminal stud on the relay marked "**Motor -**".
- 12 Connect the red wire coming from the "**Battery +**" terminal on the relay to the positive terminal on the battery. Connect the black wire coming from the "**Battery -**" to the negative terminal on the battery and tighten.
- 13 Go back and tighten any nuts / bolts that were left loose.
- 14 This kit includes a stationary controller that can be mounted in a fixed location (see figure 5) or a handheld controller for use outside of the vehicle. Connect the preferred controller to the plug coming off the relay (see figures 2 & 3).
- 15 Connect the quick connects.
- 16 If you have slack from installing the hook, then make sure the Clutch Knob is in the "**ON**" position and test the winch.
- 17 If you do not have any slack pulled out, then turn the Clutch Knob on the side of the winch to the "**OFF**" position and pull about three feet out.

- 18 Turn the Clutch Knob back to the "**ON**" position and test the winch using the chosen controller.

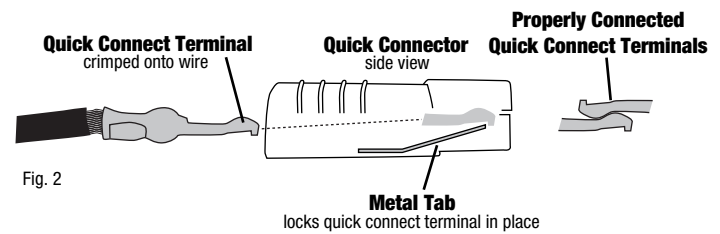

Relay mounted under the front seat on the driver side

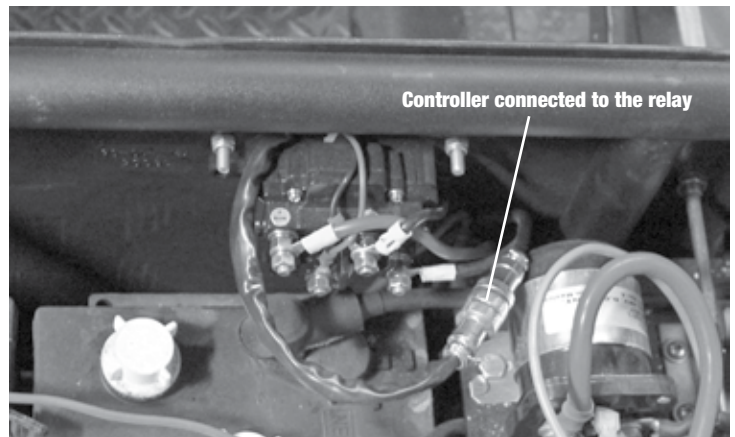

Stationary controller mounted on dash

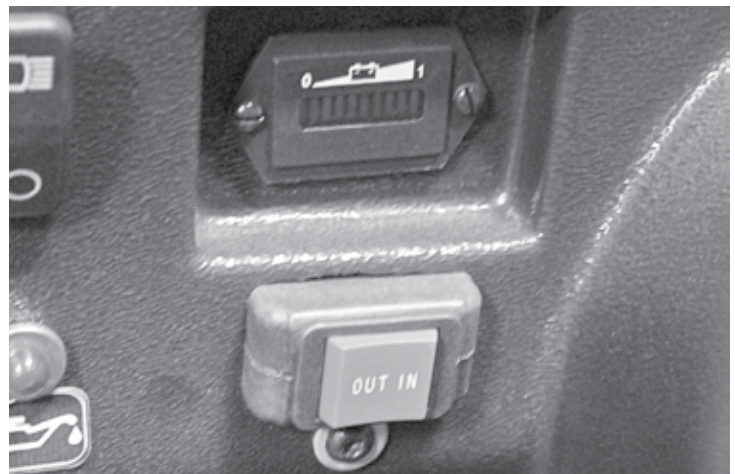

Basic Operation

Check your vehicle:

- Examine the winch cable. Do not use the winch if the cable is frayed, kinked or damaged.
- Check the Winch electrical connections to ensure that they are tight and clean.
- Put the vehicle transmission in **NEUTRAL** and apply the parking brake.

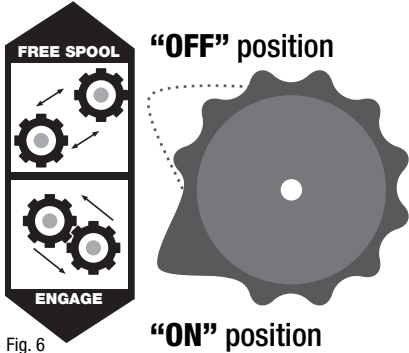

Fig. 6

Prepare the Winch:

- If the vehicle with the winch is to remain in place during the winch operation, engage the parking brake and chock the wheels (chocks sold separately).
- Use the hook strap to pull out the wire cable by moving the Clutch Control Knob to the **"OFF"** (Free Spool) position as shown in see figure 6.

WARNING Leave at least 5 full turns of wire cable on the drum.

CAUTION Do not wrap the winch cable around the object and hook onto the cable itself. This will damage the winch cable and object being pulled (see figure 7).

Attach Winch to the Object:

- Attach to the object by using a pulling point, tow strap or chain.
- Attachment point must be centered in the loop of hook and the safety clasp must be fully closed (see figure 8).
- **DO NOT use a recovery strap while winching.** They are designed to stretch and can suddenly whip back towards the operator during a winching operation.
- Place a rug or carpet over the winch cable span (approx. 6' from the hook) to help absorb the force released if the cable breaks (see figure 9).
- Move the Clutch Control Knob to the "Engaged" position and use either the stationary or handheld controller to operate the winch.

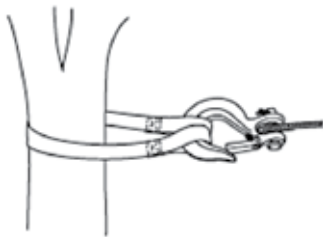

Fig. 7

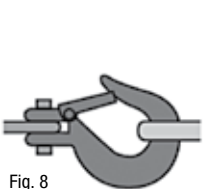
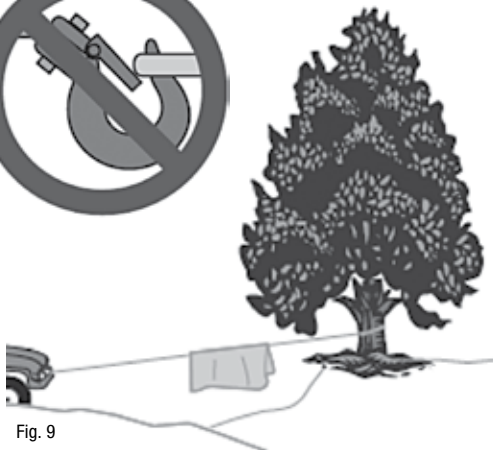

Fig. 8



Fig. 9



WARNING Winch cable may slip or break causing serious injury or death

- Briefly operate the controller that is being used (stationary or handheld) to ensure that the winch works properly.
 - **IN** - button should retract the winch cable
 - **OUT** - button should extend the winch cable
- If operation is reversed, the power connections to the winch may be connected backwards. Correct the wiring before continuing with operation.
- Standing aside the vehicle, retract the winch cable and winch the item as desired.

CAUTION Do not retract the hook all the way back into the winch roller guides as this will damage the roller and could lodge the hook in the winch

Additional Winch Information

- When finished pulling the load, secure the load and add slack to the wire cable by reversing the direction which will release tension and allow easy disconnection from the hook.

CAUTION Constant duty loading of the winch will overheat the winch motor and may cause damage to both the winch and the battery.

- **Duty Cycle: 5%** - This winch is designed for intermittent use. The duty cycle is the amount of time the winch can operate at its maximum capacity for a 15 minute period of time.
 - 45 Seconds at max rated load
 - 14 minute rest between winching at rated load
- Double line rigging can be utilized to reduce the winch load. An appropriate pulley block is included for this technique.

CAUTION Overwinding the winch cable into the roller guides can jam the winch causing it to not release with the twist knob.

WARNING THE FOLLOWING MAY CAUSE SERIOUS INJURY OR DEATH!

- Wear ANSI approved safety gear including gloves, goggles and shoes.
- Entanglement may occur. Do not wear loose clothing or jewelry, as they may get caught in moving parts. Restrain long hair.
- Do not lift items vertically.
- Do not use to lift or move people.
- Do not use vehicle to pull on the winch cable and assist the winch.
- Disconnect battery cables before working on or near the winch cable, drum, roller guides, or wire connections to prevent accidental starting.
- Inspect the winch before each use. Cracks, bent parts, frayed or kinked winch cable will weaken the integrity of the winch and may cause sudden failure. A winch with damaged components or questionable winch cable must not be used.
- Do not exceed the rated load capacity of the winch.
- Be aware of dynamic loading! Sudden load movement may briefly create excess load causing product failure.
- Do not release the clutch under load.
- Do not place fingers through the hook. Fingers may get caught and entangled in winch roller guide. Use supplied strap to hold hook.
- Stay clear of the winch cable when under load. Standing in the direct line of the winch cable or behind the winch while operating may cause serious injury or death if the winch cable were to break or slip.
- Do not use a recovery strap to winch. Recovery straps are designed to stretch and may suddenly break and spring back towards the operator.
- Secure the load after moving. **This winch is not equipped with a locking mechanism.**
- Keep at least 5 full turns of winch cable on the drum. Connection to the drum is not intended to sustain a full load.
- People with pacemakers should consult their doctor or physician before use. Electromagnetic fields in close proximity to heart pacemaker could cause pacemaker interference or pacemaker failure.

Contact American Sportworks Customer Service for questions or problems that may arise with the assembly and starting of this unit at 800-643-7332 or at amsportworks.com.