

HOOD RACK FOR WRAP AROUND BUMPER (16180)

As illustrated below, this kit consists of:

16201-2	Hood Rack	Qty: 1
16201-2	Mounting Legs	Qty: 2
2-50106	5/16 x 2 1/4 Socket Head Bolt	Qty: 2
2383	5/16 x 2 1/2 Hex Head Bolt	Qty: 2
2-50159	5/16 x 1 1/2 Hex Head Bolt	Qty: 2
2-50007	5/16 Nylon Lock Nut	Qty: 6
2-50701	5/16 Flat Washer	Qty: 6
2-50702	5/16 Curved Washer	Qty: 4

TOOLS REQUIRED

- 1/4" Allen Wrench
- 1/2" Wrench
- 1/2" Socket & Ratchet

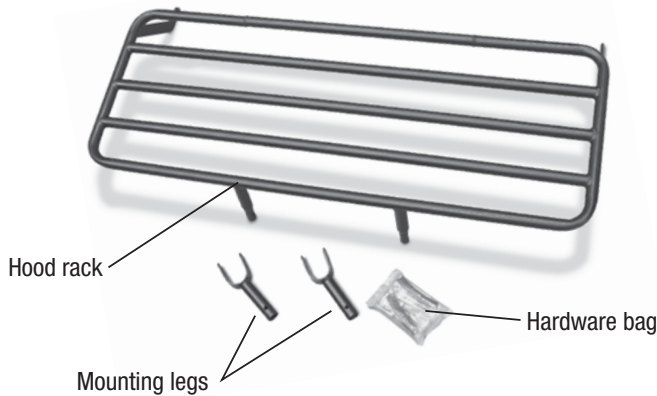

Procedure:

- 1 Remove the front bolts that hold the hood to the brush bars by first removing the nuts that secure the hood to the brush bar mounting bolt, then removing the second nut (between the hood and brush bar) from the bolt, and then removing the bolt from the brush bar. See Figure 1.

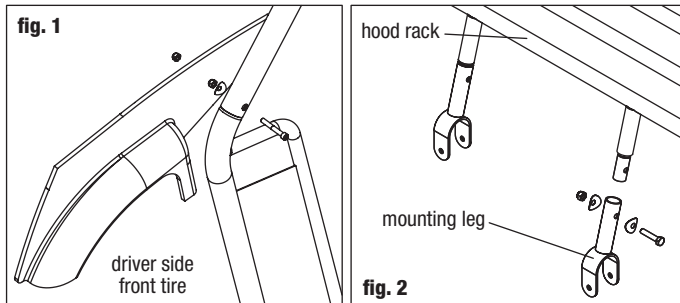

- 2 Place the mounting legs over the front posts of the cargo rack. Note their orientation and install hardware (5/16" x 1.5" bolt (2); 5/16 curved washer (4); 5/16 nylon lock nut (2)) through mounting legs and cargo rack as shown in figure 2. Do not tighten at this time.
- 3 Place open "C" clamp of mounting legs over the top tube of the bumper as shown in figure 3 (Do not install hardware at this time). Rotate the cargo rack into position so that the rear rack bracket aligns with the mounting holes in the brush bars.

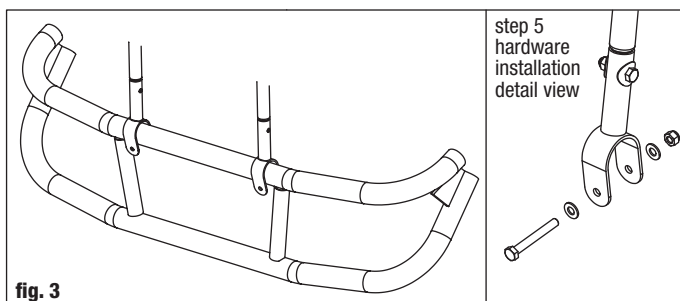

- 4 Install the new 5/16 x 2.25 socket head bolts through the cage and into the rear rack bracket. Do not tighten at this time. See figure 4.

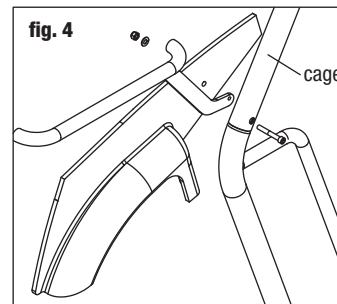

- 5 Install the hardware (5/16" x 2.5" bolt (2); 5/16 flat washer (4); 5/16 nylon lock nut (2)) through the cargo rack mounting legs at the bumper location as shown in the detail view of figure 3.
- 6 Tighten the socket head bolts at the brush guard, the fasteners connecting the mounting legs to the cargo rack, and then the fasteners connecting the mounting legs to the front bumper.
- 7 Position the hoods' mounting holes over the socket head bolts at the brush guards. Install the remaining hardware (5/16 nylon lock nut (2); 5/16 flat washer (2)) and tighten to secure the hood. Be careful not to over-tighten as this can damage the hood.