

INSTALLATION INSTRUCTIONS

VEHICLE

JEEP CHEROKEE XJ
 JEEP WAGONEER XJ
 (DOWNSIZED MODEL)

EQUIPMENT REQUIRED: CHISEL
 WIRING ACCESS LOCATION: SUV3

DRILL BITS:

HITCH REQUIRES 1/2" PIN & CLIP

WRENCHES: (TIGHTEN ALL FASTENERS WITH TORQUE WRENCH) 9/16, 3/4, 7/8, VARIOUS METRIC

3500 LB MAX GROSS TRAILER WT
 300 LB MAX TONGUE WEIGHT
 DO NOT EXCEED TOWING VEHICLE RATINGS

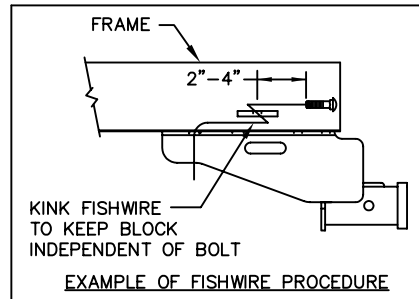
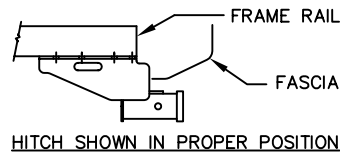

NOTE: FIVE (5) INSTALLATION OPTIONS ARE POSSIBLE DEPENDING ON VEHICLE CONFIGURATION.

- REMOVE ALL BUT A THIN LAYER OF UNDER COATING FROM ATTACHING SURFACES. ALSO, GRIND OR CHISEL OFF SMALL ALUMINUM RIVET HEADS IF PRESENT ON ATTACHING SURFACES. THIS WILL ENSURE THAT SIDE BRACKETS WILL FIT FLAT AGAINST THE FRAME RAILS.
- OPTION A** - SEE FIGURE 1
 1996 AND EARLIER VEHICLES EQUIPPED WITH FRAME MOUNTED, CLOSED SIDED, STEEL SKID SHIELD:
 - REMOVE REAR SKID SHIELD MOUNTING BOLT AND LOOSEN THE FORWARD SKID SHIELD MOUNTING BOLT, EACH SIDE SO THAT THE SKID SHIELD IS LOWERED ABOUT 1/4".
NOTE: DO NOT REMOVE FORWARD MOUNTING BOLT AT THIS TIME OR SKID SHIELD WILL COME OFF.
 - RAISE HITCH INTO POSITION, PUTTING THE RECEIVER FLANGE BETWEEN THE FRAME RAIL AND THE SKID SHIELD.
 - INSTALL THREE (3) M12 BOLTS WITH LOCK WASHERS PROVIDED (THE REARMOST ATTACHMENT HAS A HARDENED FLAT WASHER BETWEEN RECEIVER FLANGE AND LOCK WASHER), EACH SIDE AS SHOWN IN FIGURE 1. TIGHTEN FINGER TIGHT.
 - AT THIS TIME, REMOVE FORWARD SKID SHIELD MOUNTING BOLTS. PLACE TWO (2) 1/2" FLAT WASHERS AS SPACERS BETWEEN FRAME RAIL AND SKID SHIELD AND REINSTALL EXISTING M12 FASTENER.

OPTION B - SEE FIGURE 4

1997 AND LATER VEHICLES EQUIPPED WITH FRAME MOUNTED, CLOSED SIDED, STEEL SKID SHIELD:

- REMOVE THE REAR SKID SHIELD MOUNTING BOLTS, EACH SIDE.
- RAISE HITCH INTO POSITION PLACING THE HITCH OVER THE SKID SHIELD FLANGES.
- INSTALL FOUR (4) M12 BOLTS WITH LOCK WASHERS PROVIDED (THE REARMOST ATTACHMENT HAS A HARDENED FLAT WASHER BETWEEN RECEIVER FLANGE AND LOCK WASHER) EACH SIDE AS SHOWN IN FIGURE 4.

OPTION C - SEE FIGURES 1 & 2

VEHICLES EQUIPPED WITH FRAME MOUNTED TOW HOOK ON DRIVER'S SIDE:

- REMOVE TOW HOOK AND TOW HOOK BRACKET, RETURN COMPONENTS TO VEHICLE OWNER. MOUNT DRIVER'S SIDE OF RECEIVER USING M12 BOLTS AS SHOWN IN FIGURE 1.
- MOUNT PASSENGER SIDE OF RECEIVER AS DESCRIBED IN OPTION D.

OPTION D - SEE FIGURE 2

VEHICLES NOT EQUIPPED WITH FRAME MOUNTED, CLOSED SIDED, STEEL SKID SHIELD OR A FRAME MOUNTED TOW HOOK:

- FISHWIRE 1/4 X 1-1/2 X 2 BLOCK, 3/16 X 1 X 1-1/2 BLOCK AND 1/2 X 1-3/4 GR5 CARRIAGE BOLTS THROUGH END OF FRAME RAIL AND INTO EXISTING HOLES. NOTE: LEAVE FISHWIRES ATTACHED TO CARRIAGE BOLTS UNTIL LOCK WASHERS AND NUTS ARE INSTALLED. THIS WILL ALLOW BOLTS TO BE PULLED THROUGH RECEIVER AFTER RECEIVER IS POSITIONED AROUND FUEL TANK.

OPTION E - SEE FIGURE 3

VEHICLES WITH PASSENGER SIDE EXHAUST HANGER STUDS:

- REMOVE (2) NUTS FROM EXHAUST HANGER. RUBBER HANGER IN FRONT OF REAR AXLE CAN BE DETACHED TO ALLOW EXHAUST PIPE TO DROP FURTHER.
- INSTALL HITCH USING M12 X 40mm BOLTS TO EXISTING WELD NUTS OR 1/2"-13 BOLTS WITH BLOCKS TO OPEN HOLES AS SHOWN.
- ATTACH EXHAUST HANGER TO STUDS WITH ORIGINAL NUTS. HITCH WILL USE ONE STUD. REATTACH FORWARD EXHAUST HANGER.

NOTE: FISHWIRE BLOCKS THROUGH END OF FRAME RAIL IN ORIENTATION SHOWN IN FIGURE 3.
 REMOVAL OF BUMPER (4 BOLTS PER SIDE) MAY EASE FISHWIRING PROCESS.

TIGHTEN ALL 1/2 GR5 FASTENERS TO 75 LB.-FT.
 TIGHTEN ALL M12 CL 8.8 FASTENERS TO 68 LB.-FT.

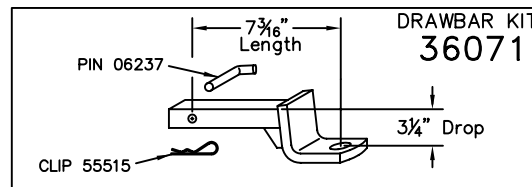

USE ONLY THE DRAWBAR SHOWN FOR CORRECT BUMPER CLEARANCE AND HEIGHT.
 DRAWBAR MUST BE USED IN THE DROP POSITION ONLY.

THIS PRODUCT COMPLIES WITH SAFETY SPECIFICATIONS AND REQUIREMENTS FOR CONNECTING DEVICES AND TOWING SYSTEMS OF THE STATE OF NEW YORK, V.E.S.C. REGULATION V-5 AND SAE J684.

APPROX WEIGHT (LB.)	FASTENER KIT
23.5	01130-469

NOTE: Check hitch frequently, making sure all fasteners and ball are properly tightened. If hitch is removed, plug all holes in trunk pan or other body panels to prevent entry of water and exhaust fumes. A hitch or ball which has been damaged should be removed and replaced. Observe safety precautions when working beneath a vehicle and wear eye protection. Follow car maker's specs for maximum trailer weight and tongue weight. Do not cut access or attachment holes with a torch.

TOWING PRODUCTS
 Plymouth, Michigan

INSTALLATION INSTRUCTIONS

VEHICLE

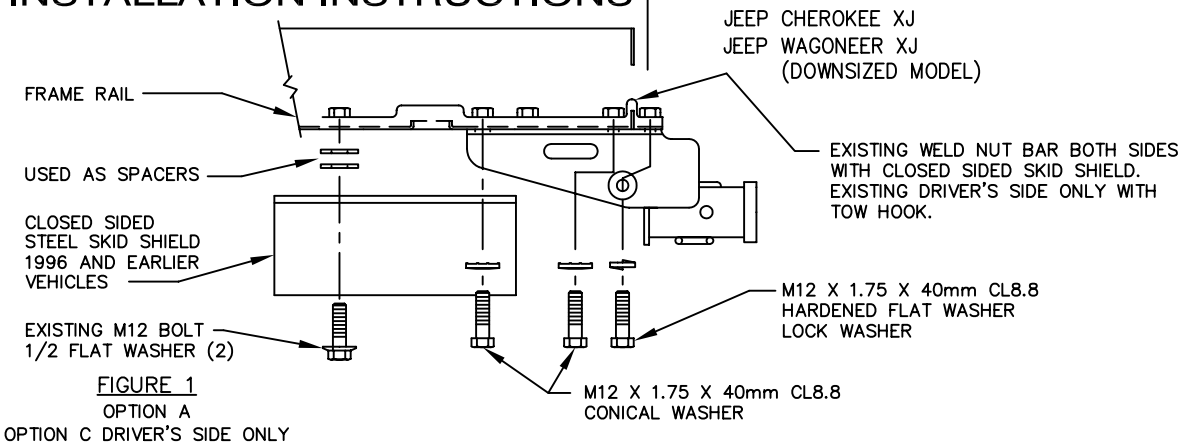

FIGURE 1
OPTION A
OPTION C DRIVER'S SIDE ONLY

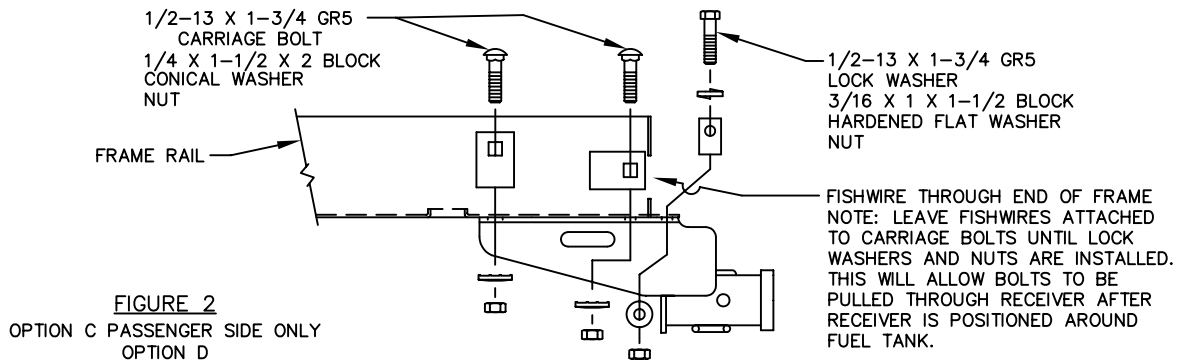

FIGURE 2
OPTION C PASSENGER SIDE ONLY
OPTION D

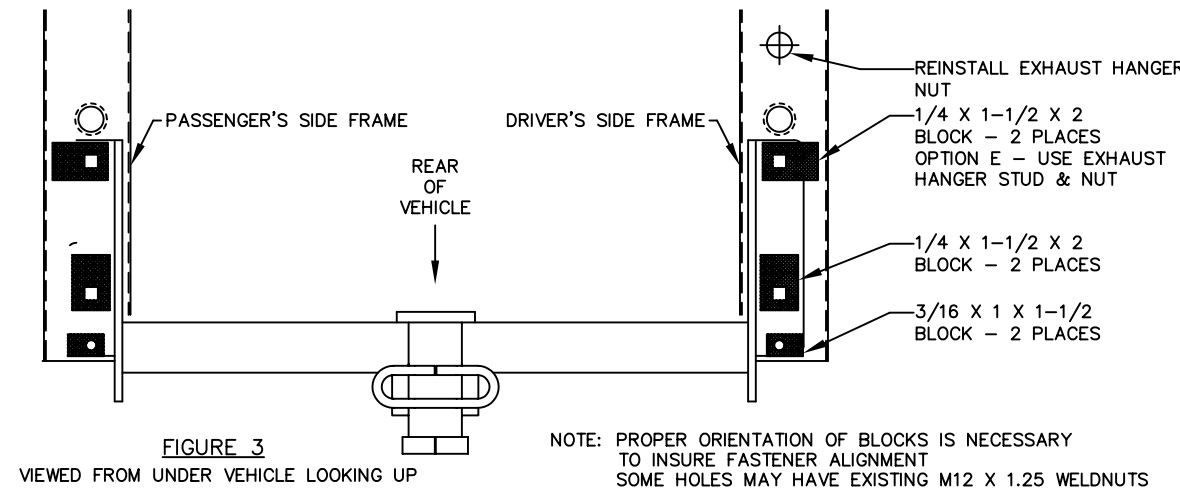

FIGURE 3
VIEWED FROM UNDER VEHICLE LOOKING UP

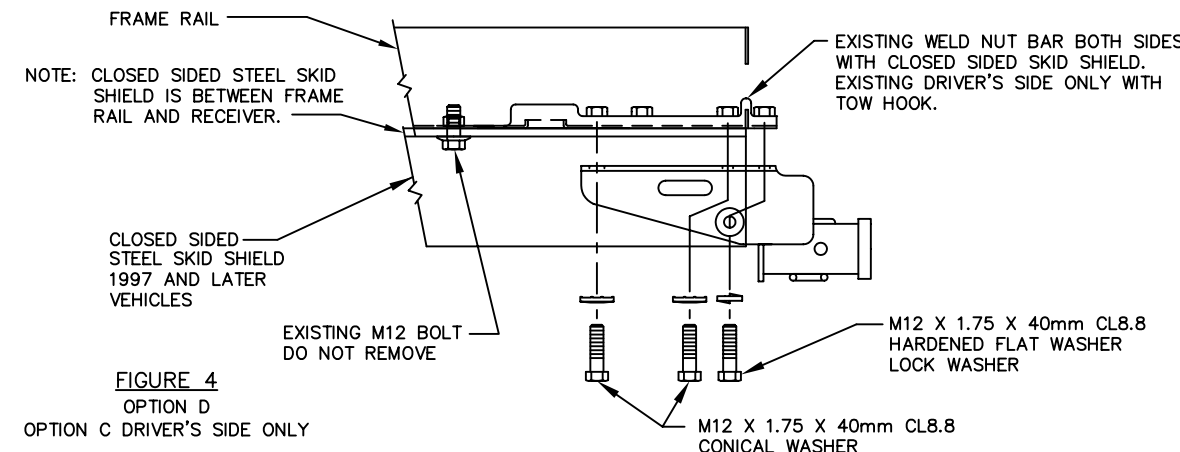

FIGURE 4
OPTION D
OPTION C DRIVER'S SIDE ONLY

APPROX WEIGHT (LB.)	FASTENER KIT
23.5	01130-469

NOTE: Check hitch frequently, making sure all fasteners and ball are properly tightened. If hitch is removed, plug all holes in trunk pan or other body panels to prevent entry of water and exhaust fumes. A hitch or ball which has been damaged should be removed and replaced. Observe safety precautions when working beneath a vehicle and wear eye protection. Follow car maker's specs for maximum trailer weight and tongue weight. Do not cut access or attachment holes with a torch.

TOWING PRODUCTS
Plymouth, Michigan