

Auto-Darkening Welding Helmets

Auto Arc[®] CARBON[™]

Auto Arc[®] TEXAS PRIDE[™]

Auto Arc[®] BURNBACK[™]

Auto Arc[®] INTENSITY[™]

Auto Arc[®] RAGE[™]

Auto Arc[®] TERMINAL VELOCITY[™]

Auto Arc[®] Graphic Camo

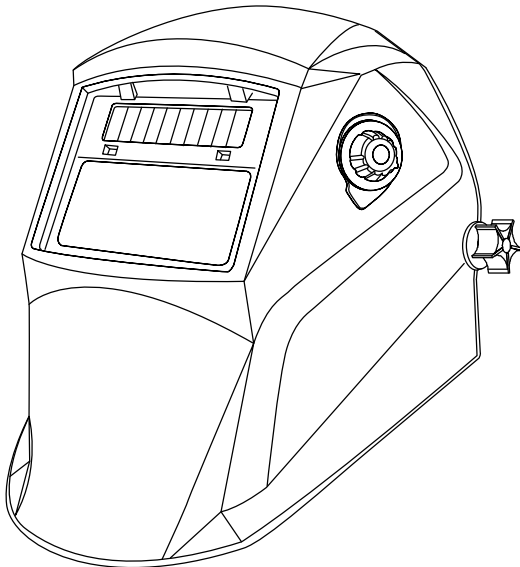

TABLE OF CONTENTS

SECTION 1 – WELDING HELMET SAFETY PRECAUTIONS –READ BEFORE USING	1
1-1. Symbol Usage	1
1-2. Arc Welding Hazards	1
1-3. Proposition 65 Warnings	2
1-4. Lens Selection Table	3
1-5. Principal Safety Standards	3
SECTION 2 – SPECIFICATIONS	4
SECTION 3 – OPERATING INSTRUCTIONS	5
3-1. Helmet Controls	5
3-2. Low Battery Indicator	6
3-3. Weld On/Grind On Switch	6
3-4. Lens Delay Control	7
3-5. Variable Shade Control (No. 9 – 13)	8
3-6. Sensitivity Control	9
SECTION 4 – ADJUSTING HEADGEAR	10
SECTION 5 – REPLACING THE LENS COVERS	11
5-1. Replacing Outside Protective Lens	11
5-2. Replacing Inside Protective Lens	12
5-3. Removing Auto-Darkening Lens Assembly	13
SECTION 6 – REPLACING THE BATTERY	14
SECTION 7 – INSTALLING OPTIONAL MAGNIFYING LENS	15
SECTION 8 – MAINTENANCE	15
SECTION 9 – TROUBLESHOOTING	16
SECTION 10 – PARTS LIST	17
SECTION 11 – LIMITED WARRANTY	18

SECTION 1 – WELDING HELMET SAFETY PRECAUTIONS – READ BEFORE USING

helmet 2012–02

-  **Protect yourself and others from injury — read, follow, and save these important safety precautions and operating instructions.**

1-1. Symbol Usage

 **DANGER!** – Indicates a hazardous situation which, if not avoided, will result in death or serious injury. The possible hazards are shown in the adjoining symbols or explained in the text.

 Indicates a hazardous situation which, if not avoided, could result in death or serious injury. The possible hazards are shown in the adjoining symbols or explained in the text.

NOTICE – Indicates statements not related to personal injury.

 Indicates special instructions.



This group of symbols means Warning! Watch Out! ELECTRIC SHOCK, MOVING PARTS, and HOT PARTS hazards. Consult symbols and related instructions below for necessary actions to avoid the hazards.

1-2. Arc Welding Hazards

-  Only qualified persons should install, operate, maintain, and repair this unit.

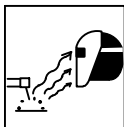

ARC RAYS can burn eyes and skin.

Arc rays from the welding process produce intense visible and invisible (ultraviolet and infrared) rays that can burn eyes and skin. Sparks fly off from the weld.

- Wear a welding helmet fitted with a proper shade of filter to protect your face and eyes when welding or watching (see ANSI Z49.1 and Z87.1 listed in Safety Standards). Refer to Lens Shade Selection table in Section 1-4.
- Wear approved safety glasses with side shields under your helmet.
- Use protective screens or barriers to protect others from flash, glare, and sparks; warn others not to watch the arc.
- Wear protective clothing made from durable, flame-resistant material (leather, heavy cotton, and wool) and foot protection.
- Before welding, adjust the auto-darkening lens sensitivity setting to meet the application.
- Stop welding immediately if the auto-darkening lens does not darken when the arc is struck. See the Owner's Manual for more information.



WELDING HELMETS do not provide unlimited eye, ear, and face protection.

Arc rays from the welding process produce intense visible and invisible (ultraviolet and infrared) rays that can burn eyes and skin. Sparks fly off from the weld.

- Use impact resistant safety spectacles or goggles and ear protection at all times when using this welding helmet.
- Do not use this helmet while working with or around explosives or corrosive liquids.
- Do not weld in the overhead position while using this helmet.
- Inspect the auto-lens frequently. Immediately replace any scratched, cracked, or pitted cover lenses or auto-lenses.



NOISE can damage hearing.

Noise from some processes or equipment can damage hearing.

- Wear approved ear protection if noise level is high.

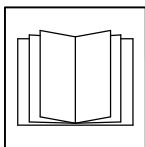

READ INSTRUCTIONS.

- Read and follow all labels and the Owner's Manual carefully before installing, operating, or servicing unit. Read the safety information at the beginning of the manual and in each section.

- Use only genuine replacement parts from the manufacturer.
- Perform maintenance and service according to the Owner's Manuals, industry standards, and national, state, and local codes.



FUMES AND GASES can be hazardous.

Welding produces fumes and gases. Breathing these fumes and gases can be hazardous to your health.

- Keep your head out of the fumes. Do not breathe the fumes.
- If inside, ventilate the area and/or use local forced ventilation at the arc to remove welding fumes and gases.
- If ventilation is poor, wear an approved air-supplied respirator.
- Read and understand the Material Safety Data Sheets (MSDSs) and the manufacturer's instructions for metals, consumables, coatings, cleaners, and degreasers.
- Work in a confined space only if it is well ventilated, or while wearing an air-supplied respirator. Always have a trained watchperson nearby. Welding fumes and gases can displace air and lower the oxygen level causing injury or death. Be sure the breathing air is safe.
- Do not weld in locations near degreasing, cleaning, or spraying operations. The heat and rays of the arc can react with vapors to form highly toxic and irritating gases.
- Do not weld on coated metals, such as galvanized, lead, or cadmium plated steel, unless the coating is removed from the weld area, the area is well ventilated, and while wearing an air-supplied respirator. The coatings and any metals containing these elements can give off toxic fumes if welded.

1-3. Proposition 65 Warnings



Welding or cutting equipment produces fumes or gases which contain chemicals known to the State of California to cause birth defects and, in some cases, cancer. (California Health & Safety Code Section 25249.5 et seq.)



This product contains chemicals, including lead, known to the state of California to cause cancer, birth defects, or other reproductive harm. *Wash hands after use.*

1-4. Lens Shade Selection Table

Process	Electrode Size in. (mm)	Arc Current in Amperes	Minimum Protective Shade No.	Suggested Shade No. (Comfort)*
Shielded Metal Arc Welding (SMAW)	Less than 3/32 (2.4) 3/32–5/32 (2.4–4.0) 5/32–1/4 (4.0–6.4) More than 1/4 (6.4)	Less than 60	7	--
		60–160	8	10
		160–250	10	12
		250–550	11	14
Gas Metal Arc Welding (GMAW) Flux Cored Arc Welding (FCAW)		Less than 60	7	--
		60–160	10	11
		160–250	10	12
		250–500	10	14
Gas Tungsten Arc Welding (TIG)		Less than 50	8	10
		50–150	8	12
		150–500	10	14
Air Carbon Arc Cutting (CAC-A)	Light Heavy	Less than 500	10	12
		500–1000	11	14
Plasma Arc Cutting (PAC)		Less than 20	4	4
		20–40	5	5
		40–60	6	6
		60–80	8	8
		80–300	8	9
		300–400	9	12
		400–800	10	14
Plasma Arc Welding (PAW)		Less than 20	6	6–8
		20–100	8	10
		100–400	10	12
		400–800	11	12
			11	14

Reference: ANSI Z49.1:2005



- * Start with a shade that is too dark to see the weld zone. Then, go to a lighter shade which gives a sufficient view of the weld zone without going below the minimum.

1-5. Principal Safety Standards

Safety in Welding, Cutting, and Allied Processes, ANSI Standard Z49.1, is available as a free download from the American Welding Society at <http://www.aws.org> or purchased from Global Engineering Documents (phone: 1-877-413-5184, website: www.global.ihs.com).

Safe Practice For Occupational And Educational Eye And Face Protection, ANSI Standard Z87.1, from American National Standards Institute, 25 West 43rd Street, New York, NY 10036 (phone: 212-642-4900, website: www.ansi.org).

SECTION 2 – SPECIFICATIONS

Cartridge Dimensions	4.33 x 3.54 x 0.39 in. (110 x 90 x 10 mm)
Viewing Field	3.82 x 1.81 in. (97 x 46 mm)
Reaction Time	0.000083 second (1/12,000 second)
Available Shades	Darkened State: No. 9 – No. 13 / Light State: No. 4
Sensors	Independent/Redundant (Two)
Operating Temperature	23°F to 131°F / -5°C to +55°C  <i>When stored in extremely cold temperatures, warm helmet to ambient temperature before welding.</i>
Storage Temperature	14°F to 158°F / -10°C to +70°C  <i>When stored in extremely cold temperatures, warm helmet to ambient temperature before welding.</i>
Power Supply	CR2450 Lithium Battery (1)
Total Weight	18 oz (515 g)
Standards	ANSI Z87.1-2003 and DIN/CE/TUV/CSA
Warranty	One year from date of purchase (see Section 11)
Sensitivity Control Light Levels	Adjusts for varying ambient light and welding arc
Delay Control	Slows lens dark-to-light state between 0.1 and 1.0 seconds (infinite dial control)
Automatic Power Off	Shuts lens Off 15–20 minutes after welding stops
Low Battery Indicator	Red LED light goes on to indicate low battery
Grind mode	Yes

SECTION 3 – OPERATING INSTRUCTIONS

3-1. Helmet Controls



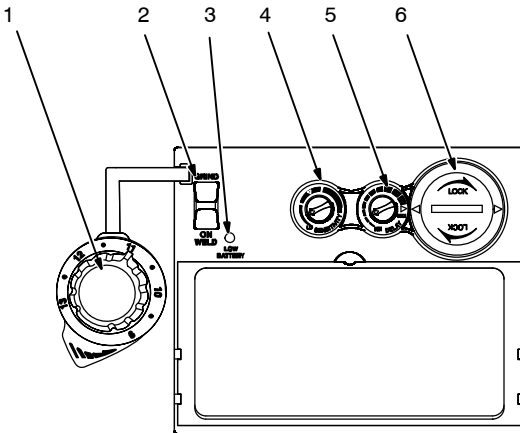

 The auto-darkening lens turns on (darkens) automatically when welding begins and turns off 15 – 20 minutes after welding stops.

- 1 Variable Shade Control (See Section 3-5)
- 2 Weld On/Grind On Switch (See Section 3-3)
- 3 Low Battery Indicator (See Section 3-2)
- 4 Sensitivity Control (See Section 3-6)
- 5 Delay Control (See Section 3-4)
- 6 Battery Compartment (See Section 6)

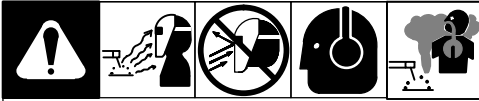

3-2. Low Battery Indicator



 The auto-darkening lens turns on (darkens) automatically when welding begins and turns off 15 – 20 minutes after welding stops.

1 Low Battery Indicator

The low battery indicator lights when 2–3 days of battery life remain.

If battery power is low, install new CR2450 lithium battery.

 Call 800-626-9420 for assistance in obtaining a new battery.

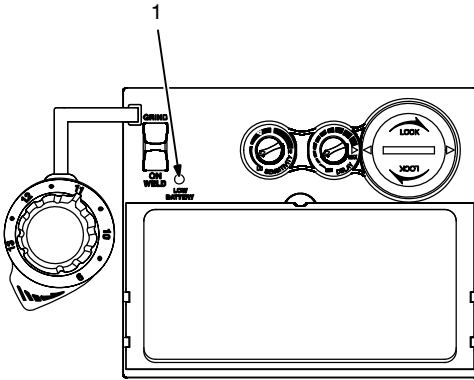

3-3. Weld On/Grind On Switch



1 Weld On/Grind On Switch

Do not weld in the Grind On mode; the lens will not darken.

For Welding applications, move the switch to the Weld On (up) position. For grinding applications, move the switch to the Grind On (down) position.

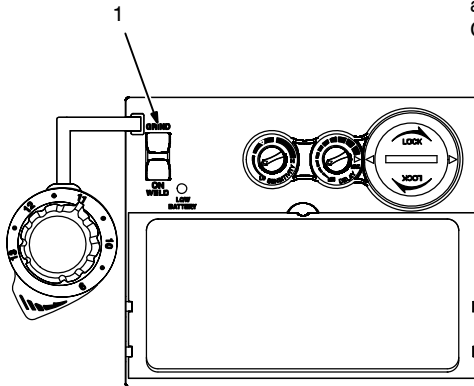

3-4. Lens Delay Control

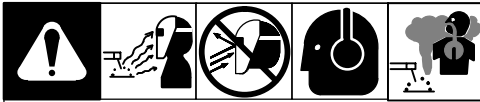

1 Lens Delay Control

The lens delay control is used to adjust the time for the lens to switch to the clear state after welding.

The delay is particularly useful in eliminating bright after-rays present in higher amperage applications where the molten puddle remains bright momentarily after welding.

Lens delay adjusts from min (0.10 second) to max (1.0 second).

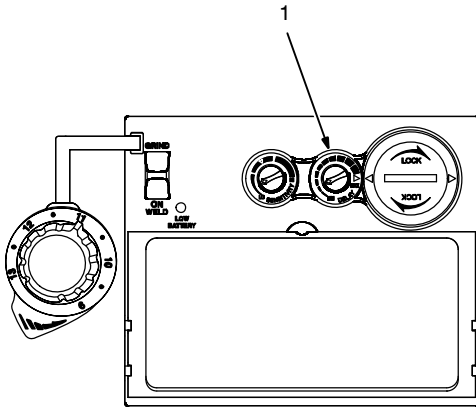

Notes

Work like a Pro!

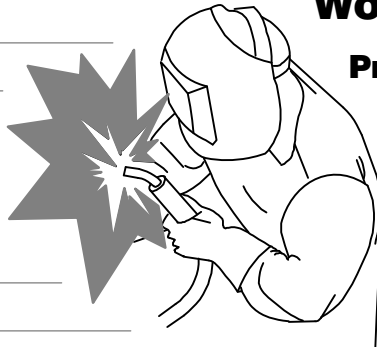

Pros weld and cut safely. Read the safety rules at the beginning of this manual.

3-5. Variable Shade Control (No. 9 – 13)

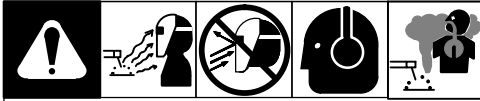

1 Variable Shade Control (No. 9 – 13)

Use the control to adjust the lens shade in the darkened state. Use the table in Section 1-4 to select proper shade control setting based on your welding process.

Start at shade 12 or 13 and adjust lighter to suit the welding application and your personal preference.

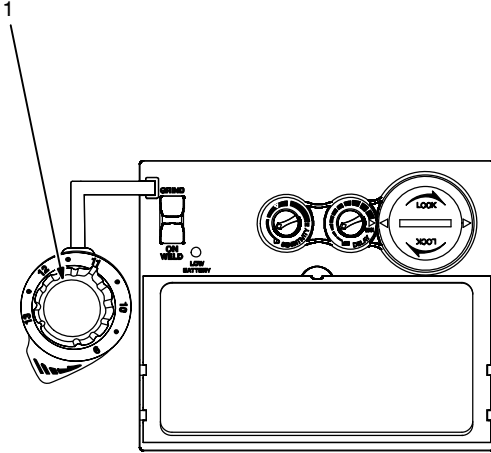

Notes

Work like a Pro!

Pros weld and cut safely. Read the safety rules at the beginning of this manual.

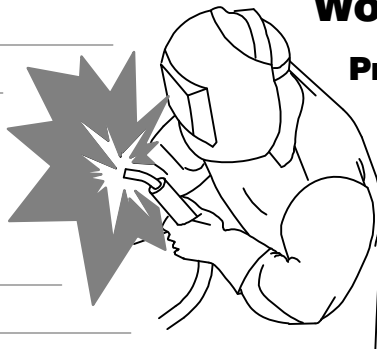

3-6. Sensitivity Control

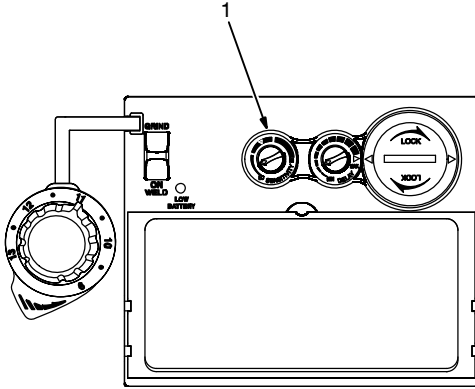
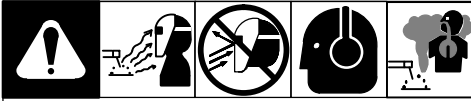

1 Sensitivity Control

Use control to make the lens more responsive to different light levels in various welding processes. **Use a Mid-Range or 30–50% sensitivity setting for most applications.**

It may be necessary to adjust helmet sensitivity to accommodate different lighting conditions or if lens is flashing On and Off. Adjust

helmet sensitivity as follows:

 *Adjust helmet sensitivity in lighting conditions helmet will be used in.*

- Turn sensitivity control to lowest setting.
- Face the helmet in the direction of use, exposing it to the surrounding light conditions.

- Gradually turn sensitivity setting clockwise until the lens darkens, then turn sensitivity control counterclockwise until slightly past setting where lens clears. Helmet is ready for use. Slight readjustment may be necessary for certain applications or if lens is flashing on and off.

Recommended Sensitivity Settings

Stick Electrode	Mid-Range
Short Circuiting (MIG)	Low/Mid-Range
Pulsed & Spray (MIG)	Mid-Range
Gas Tungsten Arc (TIG)	Mid/High-Range
Plasma Arc Cutting/Welding	Low/Mid-Range

SECTION 4 – ADJUSTING HEADGEAR

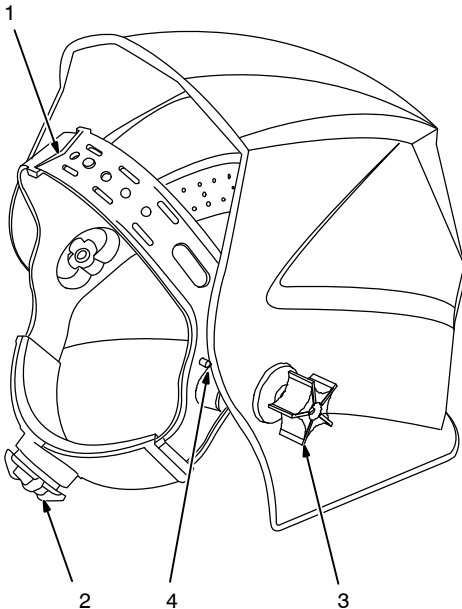
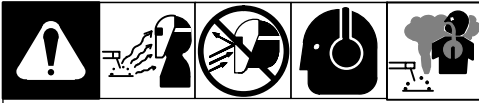

☞ *There are four headgear adjustments: headgear top, tightness, angle adjustment, and distance adjustment.*

1 Headgear Top

Adjusts headgear for proper depth on the head to ensure correct balance and stability.

2 Headgear Tightness

To adjust, push in the adjusting knob located on the back of the headgear and turn left or right to desired tightness.

☞ *If adjustment is limited, it may be necessary to remove the comfort cushion.*

3 Distance Adjustment

Adjusts the distance between the face and the lens. To adjust, loosen both outside tension knobs and press inward to free from adjustment slots. Move forward or back to desired position and retighten. (Both sides must be equally positioned for proper vision.)

4 Angle Adjustment

Four pins on the right side of the headband top provide adjustment for the forward tilt of the helmet. To adjust, loosen the right outside tension adjustment knob then lift on the control arm tab and move it to the desired position. Retighten tension adjustment knob.

☞ *When using the back distance adjustment positions, only the back three angle adjustment pins can be used.*

SECTION 5 – REPLACING THE LENS COVERS

5-1. Replacing Outside Protective Lens

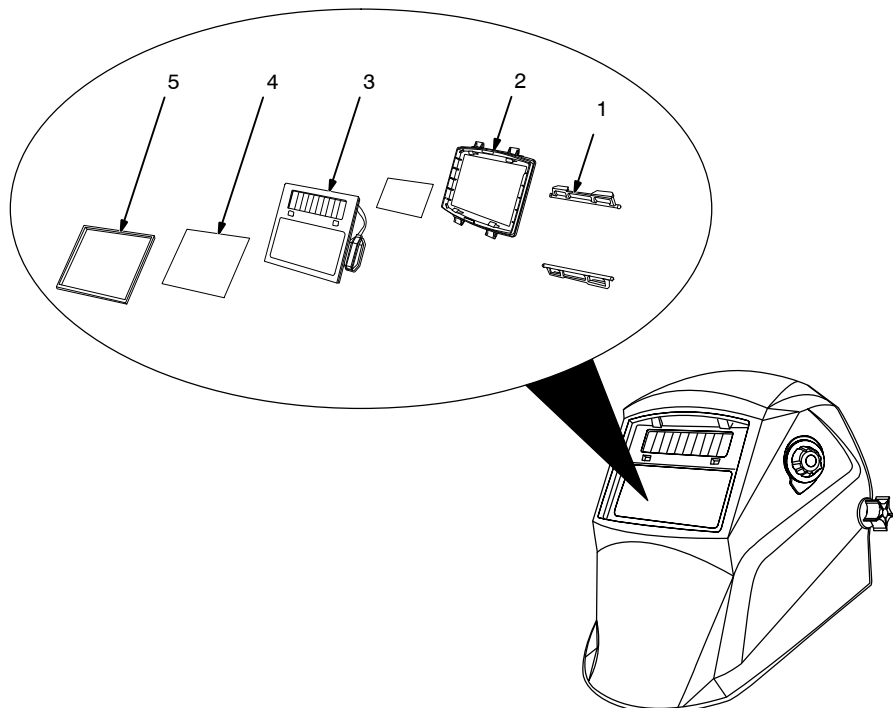
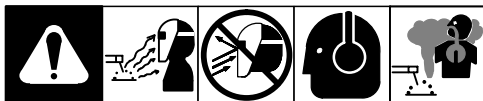

⚠ Never use the auto-darkening lens without the inside and outside lens covers properly installed. Welding spatter will damage the auto-darkening lens and void the warranty.

- 1 Auto-Darkening Lens Retainer Clips
- 2 Auto-Darkening Lens Retainer
- 3 Auto-Darkening Lens Assembly
- 4 Outside Protective Lens (Clear)
- 5 Gasket

Place helmet upside down

on a flat surface.

Adjust or remove headgear to improve access to lens assembly.

Gently release the top and bottom auto-darkening lens retainers located inside the helmet. Lift out auto-darkening lens assembly. Hold assembly and press outside lens and gasket from front. (Assembly comes out through the back of the helmet.)

Replace clear lens with new lens (Reuse the rubber gasket.)

☞ Use the rubber gasket to keep weld spatter

away from the auto-darkening lens.

Reinstall new outside protective lens with gasket and reinstall auto darkening lens in the plastic lens retainer.

Reinstall the retainer and secure the top and bottom lens retainer clips.

☞ The outside lens gasket must be correctly installed for maximum lens protection.

☞ Call 800-626-9420 for assistance in replacing lens assembly or lens covers.

5-2. Replacing Inside Protective Lens

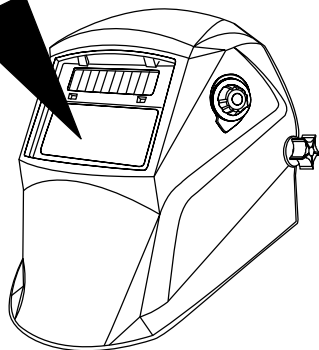
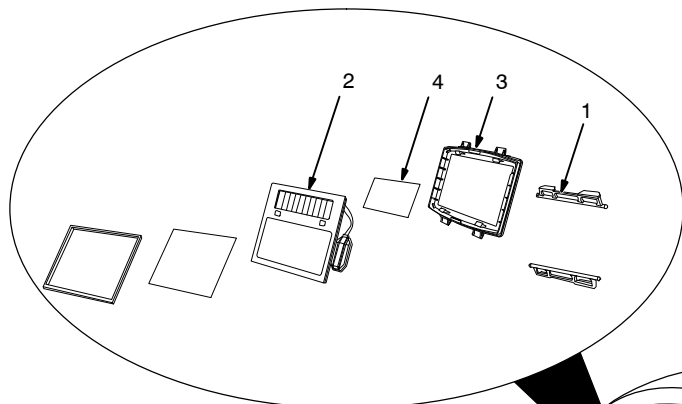

⚠ **Never use the auto-darkening lens without the inside and outside lens covers properly installed. Welding spatter will damage the auto-darkening lens and void the warranty.**

- 1 Auto-Darkening Lens Retainer Clips
- 2 Auto-Darkening Lens Assembly
- 3 Auto-Darkening Lens Retainer

4 Inside Protective Lens (Clear)

Place helmet upside down on a flat surface.

Adjust or remove headgear to improve access to lens assembly.

Gently release the top and bottom auto-darkening lens retainers located inside the helmet. Lift out auto-darkening lens assembly.

Gently remove auto darkening lens assembly from

retainer by releasing the four tabs.

Remove inside protective lens at the marked locations and replace with new lens.

☞ *Use the rubber gasket to keep weld spatter away from the auto-darkening lens.*

☞ *Call 800-626-9420 for assistance in replacing lens assembly or lens covers.*

5-3. Removing Auto-Darkening Lens Assembly

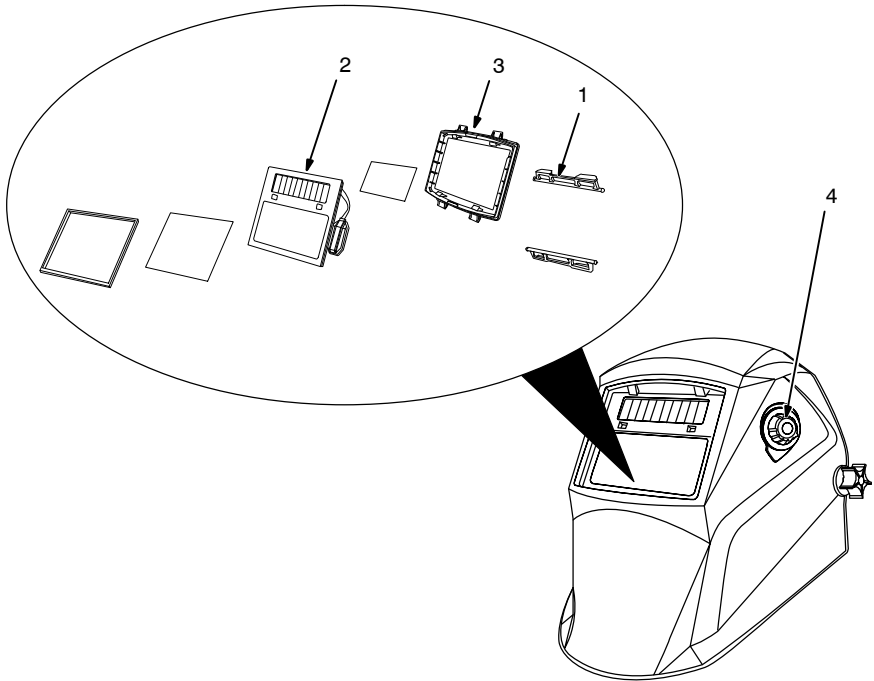

Never use the auto-darkening lens without the inside and outside lens covers properly installed. Welding spatter will damage the auto-darkening lens and void the warranty.

- 1 Auto-Darkening Lens Retainer Clips
- 2 Auto-Darkening Lens Assembly
- 3 Auto-Darkening Lens Retainer
- 4 Shade Control Knob

Place helmet upside down on a flat surface.

Adjust or remove headgear to improve access to lens assembly.

Gently release the top and bottom auto-darkening lens retainers located inside the helmet. Lift out auto-darkening lens assembly.

Gently remove auto darkening lens assembly from retainer by releasing the four tabs.

Remove the outside Shade Control knob by prying underneath with a thin object. (The knob retainer has two clips.)

Remove Shade Control retainer nut and 9 – 13 indicator ring. Remove switch assembly from the inside of the helmet.

Reinstall lens assembly in reverse order of removal.

 *Call 800-626-9420 for assistance in replacing lens assembly or lens covers.*

SECTION 6 – REPLACING THE BATTERY



1 Battery Cover

Remove battery by turning battery cover counterclockwise.

Replace with CR2450 lithium type battery.

 Be sure Positive (+) side of the battery faces up (toward inside of helmet).

 Call 800-626-9420 for assistance in obtaining a new battery.

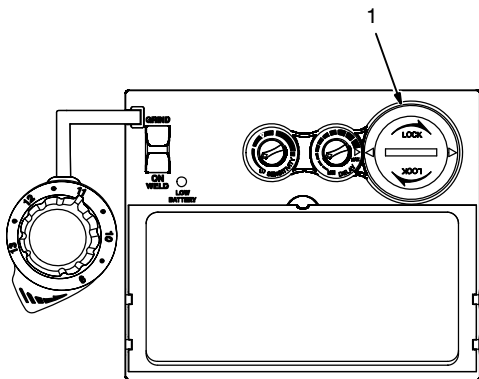

Notes

Work like a Pro!

Pros weld and cut safely. Read the safety rules at the beginning of this manual.

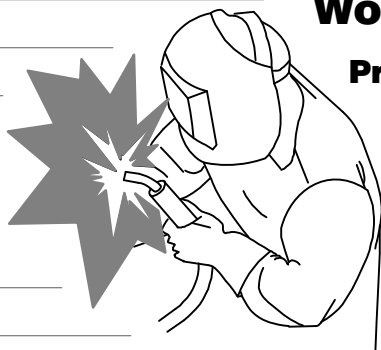

SECTION 7 – INSTALLING OPTIONAL MAGNIFYING LENS



1 Optional Magnifying Lens

Release lower lens retainer clip. Starting at the bottom, slide magnifying lens into the helmet retaining brackets. Align the magnifying lens with the auto-darkening lens assembly.

Reverse procedure to remove magnifying lens.

 *To prevent lens fogging, install flat side of magnifying lens toward auto-darkening lens.*

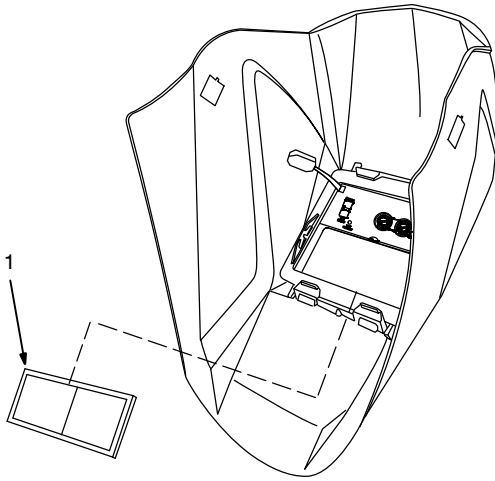

SECTION 8 – MAINTENANCE

NOTICE – Never use solvents or abrasive cleaning detergents.

NOTICE – Do not immerse the lens assembly in water.

The helmet requires little maintenance. However, for best performance clean after each use. Using a soft cloth dampened with a mild soap and water solution, wipe the cover lenses clean. Allow to air dry. Occasionally, the filter lens and sensors should be cleaned by gently wiping with a soft, dry cloth.

SECTION 9 – TROUBLESHOOTING



Trouble	Remedy
Auto lens not On – auto-lens will not darken momentarily when exposed to welding arc.	Check batteries and verify they are in good condition and installed properly. Also, check battery surfaces and contacts and clean if necessary. Check battery for proper contact and gently adjust contact points if necessary. This is particularly important if the helmet has been dropped.
Auto-lens not switching – auto-lens stays light and will not darken when welding or cutting.	<p>Stop welding immediately.</p> <p>Make sure the lens is in the Weld On mode. When in the Weld On mode the lens will darken for welding applications. Do not weld in the Grind On mode; the lens will not darken.</p> <p>Make sure the lens is turned On. If power is on, review the sensitivity recommendations and adjust sensitivity. Clean lens cover and sensors of any obstructions. Make sure the sensors are facing the arc; angles of 45° or more may not allow the arc light to reach the sensors.</p>
Auto-lens not switching – auto-lens stays dark after the weld arc is extinguished, or the auto-lens stays dark when no arc is present.	Fine-tune the sensitivity setting by making small adjustments to the control by turning it toward the “min” setting. In extreme light conditions, it may be necessary to reduce the surrounding light levels.
Sections of the auto-lens are not going dark, distinct lines separate the light and dark areas.	<p>Stop welding immediately.</p> <p>The auto-lens may be cracked which can be caused by the impact of dropping the helmet. Weld spatter on the auto lens may also cause cracking. (The lens may need to be replaced; most cracked lenses are not covered by warranty).</p>
Switching or Flickering – the auto-lens darkens then lightens while the welding arc is present.	Review the sensitivity setting recommendations and increase the sensitivity if possible. Be sure the arc sensors are not being blocked from direct access to the arc light. Check the lens cover for dirt and spatter that may be blocking the arc sensors. Increasing Lens Delay 0.1 – 0.3 second may also reduce switching.
Inconsistent or lighter auto-lens shading in the dark-state, noticeable on the outside edges and corners.	Referred to as an angle of view effect, auto-darkening lenses have an optimum viewing angle. The optimum viewing angle is perpendicular or 90° to the surface of the auto-lens. When that angle of view varies in the dark-state, welders may notice slightly lighter areas at the outside edges and the corners of the lens. This is normal and does not represent any health or safety hazard. This effect may also be more noticeable in applications where magnifying lenses are used.

SECTION 10 – PARTS LIST

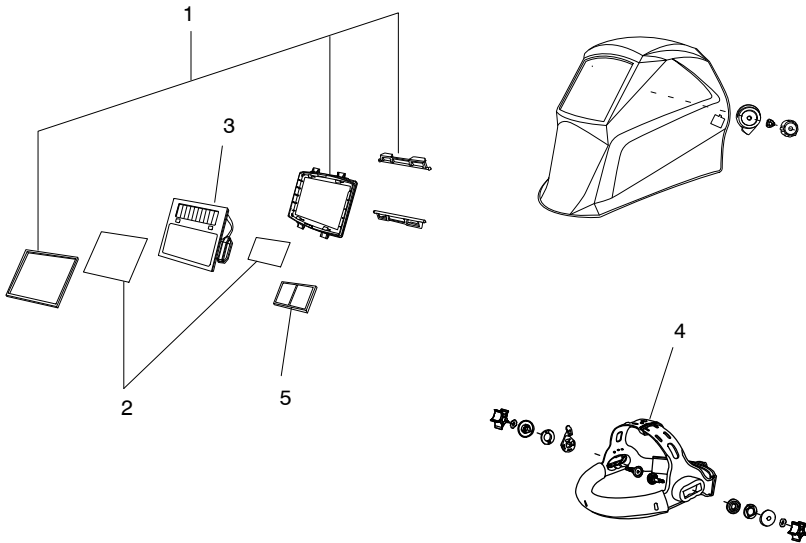

Figure 10-1. Auto-Darkening Welding Helmet

Item No.	Part No.	Description	Quantity
----------	----------	-------------	----------

Figure 10-1. Auto-Darkening Welding Helmet

1	770676	Kit, Helmet Hardware	1
2	770672	Kit, Clear Lens (Includes 5 Outside Lenses/2 Inside Lenses)	1
3	770671	Replacement Auto-Darkening Lens	1
	770284	Battery, Lithium CR2450 (Not Shown)	1
4	770613	Ratchet Headgear Assembly	1
5	770274	Dioptric Lens 150X	1
	770275	Dioptric Lens 175X	1
	770276	Dioptric Lens 200X	1
	770277	Dioptric Lens 250X	1

SECTION 11 – LIMITED WARRANTY

LIMITED WARRANTY – Subject to the terms and conditions below. Hobart Welders, Appleton, Wisconsin, warrants to its original retail purchaser that the new Auto Arc equipment sold after the effective date of this limited warranty is free of defects in material and workmanship at the time it is purchased at the retailer. THIS WARRANTY IS EXPRESSLY IN LIEU OF ALL OTHER WARRANTIES, EXPRESS OR IMPLIED, INCLUDING THE WARRANTIES OR MERCHANTABILITY AND FITNESS.

Auto Arc auto-darkening lens helmets are warranted for one (1) year from the date of purchase. **Proof of purchase is required for warranty transactions so it is imperative that a copy of the original invoice or sales receipt be retained.**

For warranty transactions, contact your original Auto Arc retailer or call 1-800-332-3281

Effective January 1, 2012



Hobart Welding Products
1635 West Spencer Street
Appleton, WI 54914 USA
Phone: 800-332-3281 (Warranty Service)
or 800-626-9420 (Product Information)



Facebook is a registered trademark of Facebook, Inc.